



SEASCAPE GENETICS IN SUPPORT OF SUSTAINABLE  
FISHERIES MANAGEMENT OF FLATFISH

GENETICA VAN MARIENE LANDSCHAPPEN TER  
ONDERSTEUNING VAN EEN DUURZAAM VISSERIJBEHEER  
VAN PLATVISSSEN

SARA VANDAMME

Dissertation presented in partial fulfilment of the requirements for  
the degree of Doctor in Science (Biology)

January 2014

Promotor:

Prof. Filip A.M. Volckaert, KU LEUVEN

Co-promotor:

Prof. Gregory E. Maes, James Cook University AUSTRALIA



© 2014 KU Leuven, Groep Wetenschap & Technologie  
Uitgegeven in eigen beheer, Sara Vandamme, Leuven

Alle rechten voorbehouden. Niets uit deze uitgave mag worden vermenigvuldigd en/of openbaar gemaakt worden door middel van druk, fotokopie, microfilm, elektronisch of op welke andere wijze ook zonder voorafgaandelijke schriftelijke toestemming van de uitgever.

All rights reserved. No part of the publication may be reproduced in any form by print, photoprint, microfilm, electronic or any other means without written permission from the publisher.

ISBN 978-90-8649-693-8  
D/2014/10.705/2

The research presented in this dissertation was funded by a grant of the Flemish Institute for Agricultural and Fisheries Research (ILVO).



# SEASCAPE GENETICS IN SUPPORT OF SUSTAINABLE FISHERIES MANAGEMENT

SARA VANDAMME

## Members of the Examination Committee:

Prof. Frans Ollevier, Chairman, KU LEUVEN;

Prof. Marleen Brans, KU LEUVEN;

Dr. Ilaria Coscia, KU LEUVEN;

Dr. Jann T. Martinsohn, European Commission, JRC;

Dr. Johan Robbens, ILVO-Fisheries;

Ir. Els Torreelle, ILVO-Fisheries



A PESSIMIST SEES THE DIFFICULTY IN EVERY  
OPPORTUNITY;

AN OPTIMIST SEES THE OPPORTUNITY IN  
EVERY DIFFICULTY.

Winston Churchill



## DANKWOORD

*This 'adventure' began a little more than five years ago. The supervisor of my master thesis, Kristiina Hilden, introduced me to the wonders of scientific research and sparked my interest to walk down this road, it seems only fair to start my acknowledgements here.*

Alhoewel dak indertijd op paddestoeln werkte, wassek toen eigenlijk al meer geïnteresseerd in vissen. Gelik dan der zovele ondertusn wel weten, als er een twa in mine kop zit, zit et ni in min ... Ezo bennek na min studies biet ILVO terecht gekomn. Woa dak gesolliciteerd eb vo een doctoraat up 'roare vis': populatie genetica op tarbot en griet met als doel het visserijbeleid te ondersteunen. Wiste kik vele woa dak up da moment an begoste... 'k Ging der noois moethn an begunn ak die kanse natuurlijk nie a moethn kriegn van een antal mensen. Stefan, zoej mie nu nog aanvaerdn aj wit wa daj wit ? Koen, de toenmaligen boas en Daan wamee da heel da idee begunn is. Solliciteren biet ILVO alljine was natuurlijk ni genoeg. De promotor vant doctroaat was ol beslist en ik moeste mie doar nog goan voorsteln. Filip, gie stelde indertid voorn om up nen disndag te komn, omdaj toen met heel 't labo goa goan eetn (en 't alternatief was nen dunderdag). 'k Dachte toen in mezelv: 'ja vele keuze ek ni é, ak ni den disndag ga, benk al ginne socialn'. En azo wast achter de lunch bie de Metropool zovere: vragen omtrent mie persoonlijk, wa dak ol gedoan en, een voorstellinge vant project en een introductie in populatie genetica door Filip en uze immer sympathieke en gepassioneerde Greg. Nu, 't moe zin dat under toen bevaln is, want anders gingek da ier noois moethn schrijven. In die vuf joar is er ondertussen wel al tjeen en tander veranderd en damee zoek ier eigenlijk ook de mensn wiln bedanken die alsan heel nauwe biet doctoraat betrokn gewist zin: Els, Johan en Marleen, ook an junder allemoale en ILVO-directie nen dikke merci!!

*Also, I would like to thank the other members of my examination committee Ilaria and Jann. Your comments helped improving my thesis!*

Alsook Prof. Ollevier, het was een leerrijke en aangename kennismaking. Ik vond het fijn dat je mijn thesis wilde beoordelen.

Een doctoraat up tarbot en griet, en toen vooral nog up Europese schaale, vereist vaneigens dater stalen zin. Damee merci an usse zeegoande waarnemers, Benny, Patrick en Glenn. Junder ulpe was lik 't schum up e pintje. En natuurlik den Willy, zonder al je connecties ginget nooit zukn succes gewist zin. Oevele kjiern zoet Greg ni gezejt en: 'ziej doa weeral met joen staalname overzicht?', tmoe zin dat de moeite was.

*To all the scientists and crewmembers of the European fisheries institutes and research campaigns: 'Thank you very much for your time, patience and effort to collect turbot and brill samples'!*

Ké zelve ook de sjanse get om een paar kjirn mee te meugn up campagne. Merci Kelle, om mie te willen meepakn up de Belgica en min zovele te ljeern! Up zee ziej natuurlijk ni aljine en werk je gelijk een team. Tis dankzij oese vaste zjimannen en natuurlijk wok Jurgen, Coenraad en David dak vele en opgestoken en een schone tied en beleefd. Iedereen die min e beetje kent, wit dak da min hartje en verloren.

*However, it was not only on the Belgian research vessel that I experienced wonderful moments. I would also like to thank Giuseppe. Instead of offering me a collection of samples, you proposed to join the survey. Of course I did.. and although my Italian was less than basic we managed very well. We had a lot of fun together with the crew, the guests from Slovenia, Croatia and of course Italy. A special thanks here to the cook, I could never get enough of your great food (although Belgians are still better in preparing fries ;-). To Laura and Igor who I will never forget: Italia numero uno ;-)*

Dak vo min doctoroat ook verbondn woare ant ILVO ek alsan een meerwaarde gevondn: der werkt ne grote verscheidenheid an mensn, elk met zin eigen expertise. 't Was boeiend om met junder te klapn zowel op als neffest 't werk. 'k Ginge noois zovele over visscherie weetn als nu! Int biezonder willek hier wel een poar mensen vernoemen. Zoals min bureaugenootjes vant 't jiste eure: Yves en Toon vo de vele toffe momenten daw toape get en. Lisa die van int begun alsan greed stond met commentaar, leuke weetjes mo vooral ook me vele ulpe en enthousiasme. Bavo, vo ol die avondn daw loate ant werkn woarn en toen derachter upt 'gemak' na Roeselare moestn. Waarom da wiender eigenlijk ni geweune tope reedn weetek eigenlijk wel ni? De mensn dak verschillende kjeern en meugn lastig valn en die min alsan goe geholpen een: Hannelore, Sabine, Pascale, Annelies, Gert, Jochen, Karl, Dirk, Lies, Jozefien, Hans H., Hans P., de Sofie's (kent toen over olle drie), Bart G. en Bart V., Antonios, Annemie en Hilde. En int biezonder ook de fishconnect staalname buddies: Kevin en Andreas. 't Wos ni aljine een aangename en leerrijke ervoaring, mo junder enthousiasme is ook vré aanstekelijk! En wie weet, misschien tot up een of ander optreden of festival. Moar an iedereen van 't ILVO ne merci, kgoan junder ni gauwe vergetn!



Gelik dak oal gezejt en, werkn up een instituut is toch ni 't zelvste of up den unief, mo kzoent ook ni anders en gewild. Kent goeie van alle twi meugn ontdek. Int begin wost wel wa zoekn tegen dak mine droai vonn. En der zin mensn die min toen vele steun en gegeven: Maarten L., den Vanhove en Bart en vaneigens ook min moatje Eveline! Greg besefte toen verzekers nog ni goed wa datn in zin hus ad gaalt at ie us voorstelde. Mo kpeisn achteraf gezien dat Daphné ook wel ni rouwig was dak joen zo vroeg en leern kenn ;-)

De mensen waarmee daj toape werkt op den unief verandern soms rap ma kzin content dak zovele mensen en meugn leern kennen. Els, Dirk, Griet, Anton en Erika en de nieuwe telgen; Sophie, Anuragh, Nele en Io: merci vo de ulpe en de leuke babbels. Mo int bijzonder willek toch de mensen vernoemen waar dak de meeste jaren bloed, zwèet en tranen mee en gedeeld: Fré, Maarten Van Steenberge, Joost, Tine, Pascal, Jasmien en Nellie. Kvin daw alsan goe en kunn tope werkn. We wistn wuk daw an mekoar adn en we woarn der ook vo mekaar (ni alljine op werkvlak). Want ken nie aljine vele bie geleerd up professioneel, ma wok persoonlijk. Ontspanninge is even belangrik dan werken en 't zin de mensn rond joe die vele maken. Wen toen ook zotte en toffe momenten beleefd!

*At a certain point however, a baby has got to leave the nest and spread its wings. It is at those moments that help comes from all around. Therefore I'd like to thank Geneviève, Eoin, Jan-Jaap, Andriaan, Paulino, Roman, Dre, Ann-Katrien, Ward, Alessia and the people who used to work with us in Leuven like Joachim, Karl, and Luisa.*

Uiteraard verdient Conny zeker een speciaal plaatsje. De ontelbare keren dat we je mocht stoor met al onze administratieve vragen, bestellingen en betalingen. Ma ik ga je vooral herinnern vo je onuitputtelijke enthousiasme en je bemoedigende woordn.

Der zin ook nog een poar mensn die nog nie vernoemt zin en die min et leven toch gemakkelijker gemaakt ebn. Een doctoraat makn tussen Leuven, Oostende en Roeselare zorgt wel vo een extra uitdaginge - we goan toen nog ma zwiegn van den nmbs. Mo dus an iederèn merci vo et bedje (en den tandebustel): Louise en Bart, Charre, Valerie, Aukelyn, Femke en Daphné.

Nog een poar mensen zoenk gern int biezoender bedankn. Gieder et min alsan hjeel nauwe bie gestoan en serieus wa meugn verdragen, oe daj da et vol gehoudn, chapeau! We zin toen ook mjeer dan geweune collega's gewordn. Los gezien van al de reste, zienk content dak junder via dit doctoraat en meugn leern kenn: Eveline, Ilse, Jo-Ann ma wok junder vintjes!

Wouter vo joen nog nen speciale merci vo ol den tied daj gestoken et in de upmoak van min figuren. En Yoke die ni alljene de kaft voorzien et van een machtige schets, mo ook de finale upmaak vo eur rekening et genomen. Wadn verzekers olle twi noois gepeist dat zovele werk ging zin aw begost zin.

'k Merke terwijl dak aant schrieven zin dat moeilijk is vo de mensen te bedanken gelijk dakt zoe willen doen. Ma khope daj zelve ook wel beseft en wit wukn dat daj vo min et gedoan en betekend et. En weetje.. we goan der anders geweune nog ne kjeer ene (of meerdere) up goan drinken ;-). 'k Weet dak iederjin de laatste tied toch wel wa verwaarloost e: merci dus vo junder geduld en tis een scha dak moar al te gern inhaaln Dus ook an alle moatn, et volgend festival, weekend, cafétocht, etentje, ..bellek ni meer of!!

Ten latste mo zeker ni minder belangrik willek nog min familie bedanken! In 't bijzonder min ma en pa: gieder et olsan et beste met us voorn get, us olsan gepushed om te doen wa daw gern doen. Zonder junder ak da ier noois gedoan. A min zuster, Tine, nja, wa moek doorup zeggen.. een boek schrieven zoe nog ni genoeg zin om te zegn wa dak wille zeggen! Mo ge wit verzekers ook beter dan gelijk wien anders, dak da ni direct mjé goan doen. Hendrik, us verhaal goat al vele langer mee dan da doctoraat. Wen al vele zeeën deur zwomn en kben content dawt tope ebn meugn en kunnen doen. Ook joen familie willek bedanken vo de vele steun, interesse en ulpe!

Eigenlijk is de conclusie (wukn beroepsmissvorming) daw us meugn gelukkig stellen met de meugelikheden daw kriegten en de mensn daw leern kennen. Want tis door de goeie mo ook de up de minder gemakkelijke momenten daj mekoar en jezelfe leert kenn en appreciërn.

*Sara*

## SUMMARY

In 1883, Thomas Huxley put forward that *all the great sea fisheries are inexhaustible*. This illustrates the classical notion that marine environments tend to be demographically 'open' without any chance of complete extinction. Such belief was based on the wide distribution of many marine species with extensive larval and adult dispersal, and large population sizes, even after heavy exploitation. However, the classical view of inexhaustible fisheries has proven incorrect after major declines in many world fisheries the last decades, prompting for a better understanding of fishery stock demography and connectivity using multidisciplinary approaches. Fisheries research has gained from the integration of genetic studies showing the various mechanisms explaining the evolution of population structure in the ocean. The resilience of fish populations and the maintenance of genetic diversity has important implications for the viability and stability of entire ecosystems under heavy exploitation.

In this thesis, I aim at integrating novel knowledge on the genetic composition of flatfish stocks with fisheries management tools. Therefore, the genetic structure was investigated of the flatfish turbot and brill, in the Northeast Atlantic Ocean. A combination of conventional population genetic analyses and multivariate statistics was used to assess how environmental factors influence the genetic variation at various spatio-temporal scales. The focus was on several flatfish species with a synchronic sampling design. The seascape genetic approach made it possible to identify the interaction between oceanography and species-specific traits, and their effect on the true dispersal of the species. In the case of turbot, the combination of anonymous and gene-based nuclear markers proved useful for elucidating potential population units as each shows a different level of differentiation. This approach is highly valuable from a conservation perspective, as it allows one to infer the effect of 'community-wide' fragmentation.

Common geographic patterns were identified in the genetic structure. However, differences in sensitivity to gene flow barriers were reported. This discrepancy was driven by species-specific traits, particularly reproductive behavior. Within the Northeast Atlantic Ocean, I could distinguish two large groups: one comprising the Skagerrak-Kattegat area and a second along the Irish shelf. For turbot, another population might even be present in the Baltic Sea. Seascape genetic analyses based on putatively selective markers suggest an additional gene flow barrier within the North Sea, linked to the Friesian frontal zone.

For a species like turbot, with a wider distribution range in the North Sea than flatfish such as sole and brill, the identification of this barrier has an important implication for the delineation of management units.

At present, the incorporation of genetic data into statistical fisheries models has been limited. This is mainly because genetic research draws inferences about populations on an evolutionary time scale, while fisheries management is more interested in short-term demographic independence. Fisheries models usually lead management instruments towards short-term gains. But the long-term vision of sustainable fisheries management also needs to take evolutionary consequences into account. Our findings suggest that turbot could serve as a so-called 'umbrella species', i.e. a vulnerable species whose environmental requirements encapsulate the needs of most other species. It represents a foundation for appropriately managing "seascapes" in order to preserve diversity. Using turbot for that purpose has two advantages: 1) the impact of environmentally driven connectivity is most straightforward in turbot, and 2) turbot seems most vulnerable to the negative effects of fisheries and can therefore serve as the proverbial 'canary in the coal mine' – an indicator of declining environmental quality.

This implies that policymakers will have to make trade-offs to serve all marine stakeholders in the best possible way without jeopardising the long-term gains. Scientists can help to address these trade-offs. They can meet the needs of the stakeholders by communicating scientific results on all administrative levels as well as informing policy-makers of these results and the impact they may have on the ecosystem. Scientific research results are normally communicated via peer-reviewed publications and participation in conferences. At the same time, scientists must communicate through their national fisheries institutes, because these institutes play a key role in communicating between politicians, stakeholders and scientists. Such a communication strategy would not only transfer knowledge but will also help to tackle the problems related to a mismatch between the knowledge produced and the knowledge that policymakers actually need.

Finally, it has become clear in recent years that unexpected management outcomes stem from human behavior related to uncertainty. The ecosystem is not yet sufficiently understood, and it shall never be completely understood because of its inherent variability and associated uncertainties. To address and reduce uncertainty, managers will have to incorporate information about resource user behavior provided by the social sciences. Such information depends largely on improved interdisciplinary communication among scientists.

Often uncertainty in scientific results is reduced via the peer review process for high-level journals, usually restricted to a specific field. By expanding research to involve other disciplines and increasing efforts to improve communication between scientists and other actors, more and better knowledge will be produced and uncertainty will be further reduced. The ICES structure and workflow play a crucial role in creating an atmosphere for trans- and multi-disciplinary research. Working in a transnational context to stimulate interdisciplinary research and communication will encourage rapid and sure progress towards improved sustainability of sea fisheries.



## SAMENVATTING

*All the great sea fisheries are inexhaustible*, het bekend citaat van Thomas Huxley in 1883 illustreert de klassieke visie dat de mariene omgeving demografisch ‘open’ is en uitsterven onmogelijk. Deze gedachte was gebaseerd op het feit dat veel mariene soorten wijd verspreid zijn door hun groot vermogen tot dispersie en enorme populatiegrootte. In de laatste decennia werden wereldwijd echter sterke dalingen waargenomen in verschillende visstocks. Dit toont niet alleen aan dat deze klassieke visie fout is, maar dat een betere kennis omtrent dynamiek van vis stock en connectiviteit aan de hand van multidisciplinaire technieken hoogst nodig is. De integratie van genetische studies in visserij onderzoek heeft reeds verschillende mechanismen bloot gelegd die verklaren hoe mariene populaties evolueren. De veerkracht van vispopulaties en het behoud van hun genetische diversiteit heeft dan ook belangrijke implicaties voor de levensvatbaarheid en stabiliteit van het hele ecosysteem onder intensieve exploitatie.

In deze studie beoog ik om nieuwe kennis omtrent de genetische samenstelling van platvissen te integreren met methodes voor visserijbeheer. Hiervoor werd de genetische structuur bestudeerd van de platvissen tarbot en griet in de Noordoost Atlantische Oceaan. De combinatie van traditionele populatie genetische analyses en multivariate statistieken liet toe om de invloed na te gaan van omgevingsfactoren op de genetische variatie in ruimte en tijd. De focus werd gelegd bij meerdere platvissoorten die synchroon werden bemonsterd. De landschapstechniek maakte het mogelijk om de interactie tussen oceanografische factoren en soort-specifieke kenmerken te ontrafelen evenals hun effect op de gerealiseerde dispersie. In het geval van tarbot, leverde de combinatie van anonieme en gen-gekoppelde nucleaire merkers complementaire informatie op met betrekking tot het afbakenen van populaties, daar elke merkersoort een verschillende graad van genetische differentiatie vertoont. Deze aanpak is waardevol voor het behoud van vissen in het algemeen, aangezien zij toelaat om het effect van fragmentatie op gemeenschapsniveau na te gaan.

Gemeenschappelijke geografische patronen konden geïdentificeerd worden in de genetische structuur, maar er werden verschillen waargenomen in de gevoeligheid voor barrières in genmigratie. Deze discrepantie wordt voornamelijk bepaald door het soort-specifieke voortplantingsgedrag. In de Noordoost Atlantische Oceaan werden twee grote populaties onderscheiden, namelijk een populatie in het Skagerrak-Kattegat en een tweede populatie op het Ierse continentaal plat. Bijkomend werden aanwijzingen gevonden dat tarbot in de Baltische Zee als een aparte populatie voorkomt.

Het gebruik van mariene landschapstechnieken en potentieel selectieve merkers liet tevens toe een genmigratie barrière te identificeren in de Noordzee, gekoppeld aan het Friese front. De aanwezigheid van zo'n barrière kan voor tarbot belangrijke gevolgen hebben bij het afbakenen van beheerseenheden, daar tarbot in de Noordzee een wijder verspreidingsgebied heeft dan soorten zoals tong en griet.

Tot op vandaag worden resultaten van genetische studies zelden gebruikt in statische visserij modellen en visserijbeheer, wat voornamelijk te wijten is aan tijdsdiscrepantie. Daar waar genetisch onderzoek toelaat conclusies te trekken op een evolutionaire tijdsschaal, zijn visserijmanagers meer geïnteresseerd in demografische effecten op korte termijn. Bijgevolg worden beheersinstrumenten en restricties opgelegd in het voordeel van korte-termijn opbrengsten. Niettegenstaande kan het negeren van de evolutionaire effecten veroorzaakt door visserij de lange termijn visie ondermijnen. Deze studie toont aan dat tarbot kan aanschouwd worden als een 'kapstok' soort, namelijk een soort wiens omgevingsnoden ook deze van andere soorten vertegenwoordigt. Enerzijds is de invloed van het mariene milieu het meest uitgesproken voor tarbot, anderzijds is deze soort ook het meest kwetsbaar voor de negatieve effecten van visserij. Daarom zou tarbot als basis kunnen dienen bij het indelen van beheerseenheden voor demersale vissoorten. We erkennen dat op korte termijn dit een negatieve invloed kan hebben op de opgelegde vangstquota voor soorten die in dezelfde visserij gevangen worden.

Dit betekent dat beleidsmakers afwegingen moeten maken die toelaten om alle belanghebbende gebruikers van de zee zo goed mogelijk tegemoet te treden zonder echter de lange-termijn opbrengsten in gevaar te brengen. Wetenschappers dienen hierbij een belangrijke rol te spelen, maar daarvoor is een goede communicatie vereist tussen alle actoren omtrent hun resultaten en de impact die ze hebben op het ecosysteem. Verschillende communicatie mogelijkheden lenen zich hier toe waarbij deelname aan congressen en publicaties van rapporten en artikels het meest voor de hand liggen. Doch zal een goede communicatie via de nationale visserijinstituten van cruciaal belang zijn, daar deze instellingen spilfiguren zijn in communicatie tussen beleidsmakers, wetenschappers en belanghebbenden. Niet alleen worden langs deze weg de onderzoekresultaten overgedragen, maar wordt ook het probleem aangepakt in verband met de mismatch tussen nieuwe kennis en nuttige kennis om beleidsmakers toe te laten keuzes te maken.



Tenslotte is het in de laatste jaren duidelijk geworden dat onverwachte uitkomsten van beheersmaatregelen het resultaat zijn van menselijk gedrag ten gevolge van onzekerheden. Tot op heden is de kennis over het ecosysteem onvoldoende om met 100% zekerheid het beleid te ondersteunen. Echter door de grote variabiliteit en onzekerheden die hiermee gepaard gaan, zal wetenschap nooit 100% zeker zijn. Om hierop te anticiperen, zullen beleidsmakers zich moeten informeren over de gevolgen van het invoeren van bepaalde beheersmaatregelen. Dit vereist een verbrede interdisciplinaire communicatie tussen wetenschappers, waarbij het instituut ICES een belangrijke rol speelt. Niet alleen omdat hun uitgebreide peer-review adviesproces de onzekerheid van wetenschappelijke resultaten behandelt, maar ook omdat ze trans- en multidisciplinair onderzoek promoten. De voortdurende inspanning om kennis te produceren en zo onzekerheden te verminderen, in combinatie met verhoogde inspanningen om de communicatie tussen wetenschappers te verbeteren, stelt ons in staat om een snelle en veilige vooruitgang te boeken. Dit zal leiden tot een duurzame visserij waarbij zowel de fauna, het ecosysteem als alle betrokkenen baat hebben.



## **ABBREVIATIONS AND DEFINITIONS**

### **A**

AC	Advisory Committees
ACFA	Advisory Committee on Fisheries and Aquaculture
ADR	Adriatic Sea
AIC	Akaike Information criterion
ALD	Åland Sea
ALV	Agency of Agriculture and Fisheries
AR	Allelic richness
ARK	Arkona Sea

### **B**

BCH	Bristol Channel
BEL	Belt Sea
BLS	Black Sea
BOB	Bay of Biscay
BSS	Bottom shear stress

### **C**

CAP	European Common Agricultural Policy
CCAMLR	Committee for the Conservation of Antarctic Marine Living resources
CCRF	Code of Conduct for Responsible Fisheries
CFP	Common Fisheries Policy
COI	Cytochrome oxidase subunit I

### **D**

DCF	Data Collection Framework
DCMAP	Multi Annual Program for Data Collection
DG	Directorate- General
DG MARE	Directorate-General for Maritime Affairs and Fisheries

## **E**

EAFM	Ecosystem Approach to Fisheries Management
EC	European Commission
EEC	Eastern English Channel
EEZ	Exclusive Economic Zone
EFF	European Fisheries Fund
EMFF	European Maritime and Fisheries Fund
EMODnet	European Marine Observation and Data Network
ENS	Eastern North Sea (German Bight)
EP	European Parliament
EPC	Extended Peer Community
ERA	European Research Area
EST	Expressed Sequence Tags Estonian Coast
EUROSTAT	Statistical Office of the European Communities
EVA	External Independent Agencies

## **F**

FAO	Food and Agriculture Organization
FGF	Fibroblast growth factor
FIVA	Financial Instrument for the Flemish Fishing and Aquaculture Industry
FPS	Federal Public Service

## **G**

GDP	Gross Domestic Product
GES	Good Environmental Status
GFCM	General Fisheries Commission for the Mediterranean
GOT	Gotland Island

## H

$H_d$	Haplotype diversity
$H_{exp}$	Expected heterozygosity
$H_{obs}$	Observed heterozygosity

## I

IBPNew	Inter-Benchmark Protocol on New Species (Turbot and Sea bass)
ICE	Iceland
ICES	International Council For The Exploration Of The Sea
ICES Rectangles:	IIIc, IIIb and IIIa                      Kattegat and Skagerrak
	IVb, IVc, VIId, VIle                      North Sea and English Channel
	VIIf, VIIg, VIIa                          Celtic and Irish Sea
	VIa and VIIb                              west coast of Ireland
	VIIIa,b                                      Bay of Biscay
	IXa and VIIIc                            Portugal
	Iva    Southwest coast of Norway
	Va2                                        Iceland
ICCAT	International Commission for Conservation of Atlantic Tuna
ILVO	Institute for Agricultural and Fisheries Research
IMP	Integrated Maritime Policy
IRS	Irish Sea
ISS	Index of substitution saturation
ITQ	Individual Transferable Quota
IVA	Internal Autonomous Agencies

## J

## K

$K$	Number of clusters
KAV	Golf of Kavala
KAT	Kattegat

Kya                      Thousand years ago

## **L**

LGM                    Last Glacial Maximum

LHT                    Life History Traits

## **M**

MAP                    Multi-annual Plan

MCMC                Markov Chain Monte Carlo

MDS                    Multidimensional Scaling

MEM                   Moran Eigenvector Map

MEY                   Maximum Economic Yield

ML                     Maximum Likelihood

MPA                    Marine Protected Areas

MSFD                Marine Strategy Framework Directive

MSP                    Maritime Spatial Planning

MSY                    Maximum Sustainable Yield

Mya                    Million years ago

## **N**

NAFO                Northwest Atlantic Fisheries Organisation

$N_c$                     Census population size

$N_e$                     Effective population size

NGO                    Non-Governmental Organisations

NNS                    West Coast of Norway

NSRAC                North Sea Regional Advisory Council

NWS                    North West Spain

NWWRAC            North Western Waters Regional Advisory Council

## **O**

## **P**

PCNM	Principal Coordinate Analysis of Neighbour Matrices
PCR	Polymerase Chain Reaction
PECH	Parliament Commission for Fisheries
PNS	Post-Normal Science
POR	Portuguese Coast
PP	Primary Production
PYC	Depth of Pycnocline

## **Q**

## **R**

RAC	Regional Advisory Councils
RAXML	Randomized Accelerated Maximum Likelihood algorithm
RDA	Redundancy analysis

## **S**

SALV	Strategic Advisory Board on Agriculture and Fisheries
SBS	Salinity of the Bottom Waters
SBT	Temperature of the Sea Bottom
SDVO	The Foundation for Sustainable Fishery Development
SEI	South East Ireland
SNS	Southern North Sea
SSR	Simple Sequence Repeat
SST	Temperature of the Sea Surface
SSS	Salinity of the Surface Waters
STECF	Scientific, Technical and Economic Committee for Fisheries
STRAT	Density based Stratification index
SWWRAC	South Western Waters Regional Advisory Council

## **T**

$T_a$	Annealing temperature
TACs	Total Allowable Catches
TFC	Transferable Fishing Concessions
tMRCA	time to Most Recent Common Ancestor

## **U**

UN	United Nations
UNCED	UN Conference on Environment and Development
UNCLOS	United Nations Convention on the Law of the Sea

## **V**

VLAM	Flemish Centre of Agro- and Fisheries marketing
VPA	Virtual Population Analysis

## **W**

WEC	Western English Channel
WGAGFM	Working Group on the Application of Genetics in Fisheries and Mariculture
WGFS	Working Group on Fisheries Systems
WGNEW	Working Group on Assessment of the New MoU Species
WIR	West Ireland
WSC	West Scotland

## **X**

## **Y**

## **Z**







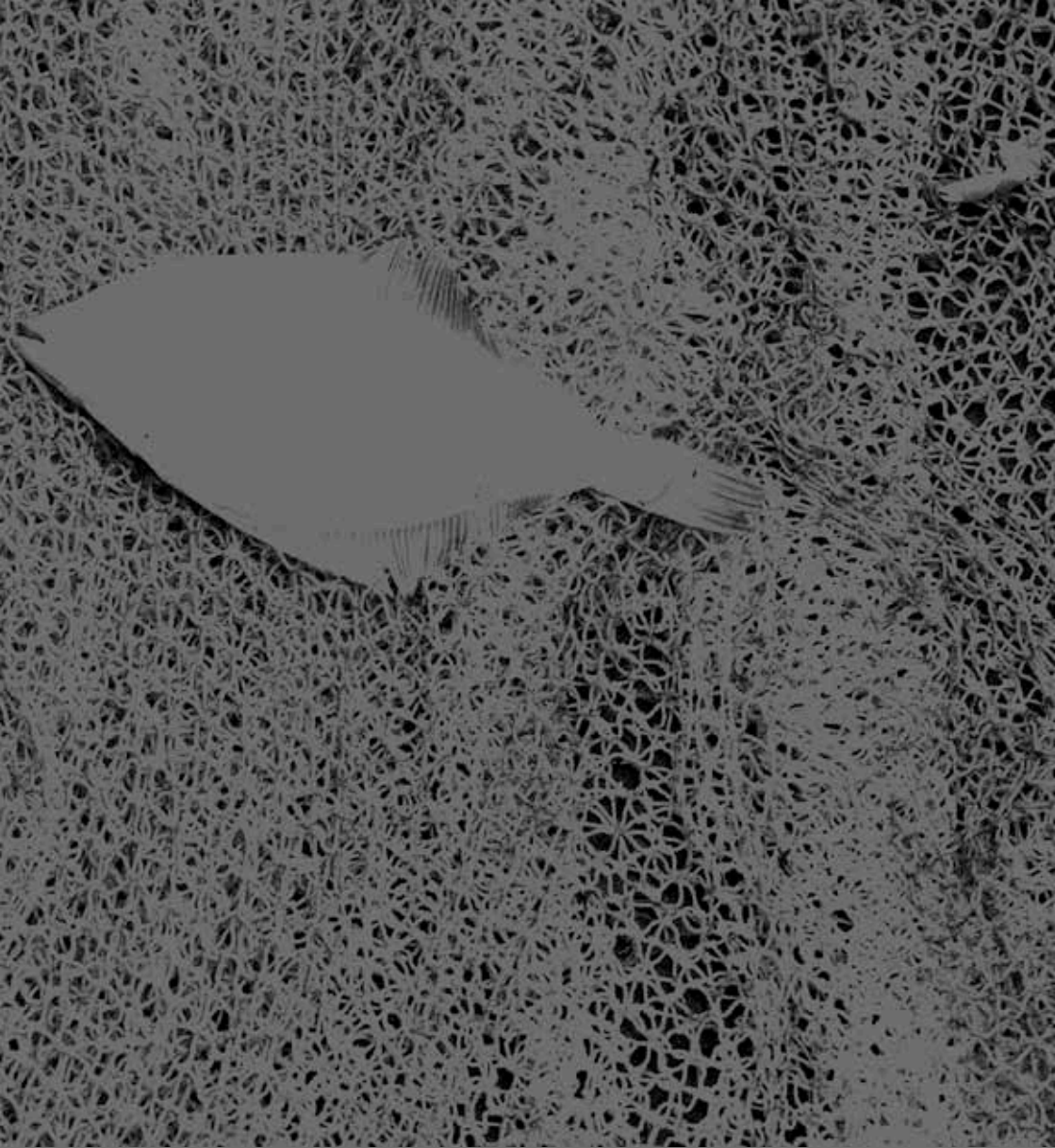

# Chapter 1

## General introduction

Foto: © Karl Van Ginderdeuren



# Chapter 1

## General introduction and aims

### 1 BACKGROUND

Ecosystems are under constant pressure. Environmental forces like climate change influence the structure and functioning of marine ecosystems, but human use has also altered the oceans through direct and indirect means (Halpern *et al.* 2008; Megrey *et al.* 2009; Lo Brutto *et al.* 2011). Although human activities vary in their spatial distribution and intensity of impact, not any area in the ocean, not even the most remote one, is left untouched by humans (Halpern *et al.* 2008). Fishing remains one of the largest factors modifying marine ecosystems (Worm *et al.* 2006; Crowder *et al.* 2008) due to several unintended consequences (Figure 1), including habitat destruction, incidental mortality of nontarget species, evolutionary shifts in population demographics and changes in the function and structure of ecosystems (Pikitch *et al.* 2004; Crowder *et al.* 2008; Schindler *et al.* 2010). To prevent the collapse of ecosystems and fish stocks worldwide, and secure the economies and livelihoods that depend on them, international treaties have called for an ecosystem based approach to fisheries management (EAFM) (Myers & Worm 2003; Pikitch *et al.* 2004; Pauly *et al.* 2005).

Species-rich communities are thought to produce more temporally stable ecosystem services. Whenever species are unable to adapt to these anthropogenic changes and pressures, local populations may either go locally extinct or disperse. Other species can complement or independently perform similar ecosystem functions (Tilman 1996; Crowder *et al.* 2008; Schindler *et al.* 2010). However, it is important not to neglect the biologically relevant diversity within individual species (Kenchington 2003; Hauser & Carvalho 2008; Schindler *et al.* 2010). Current rates of population extirpation are at least three orders of magnitude higher than species extinction rates (Hughes *et al.* 1997). Hence, there is a pressing need to clarify how diversity within species and life history diversity affect the performance of individual species in providing important ecosystem services (Hilborn *et al.* 2003a; Kelly & Codling 2006; Schindler *et al.* 2010).

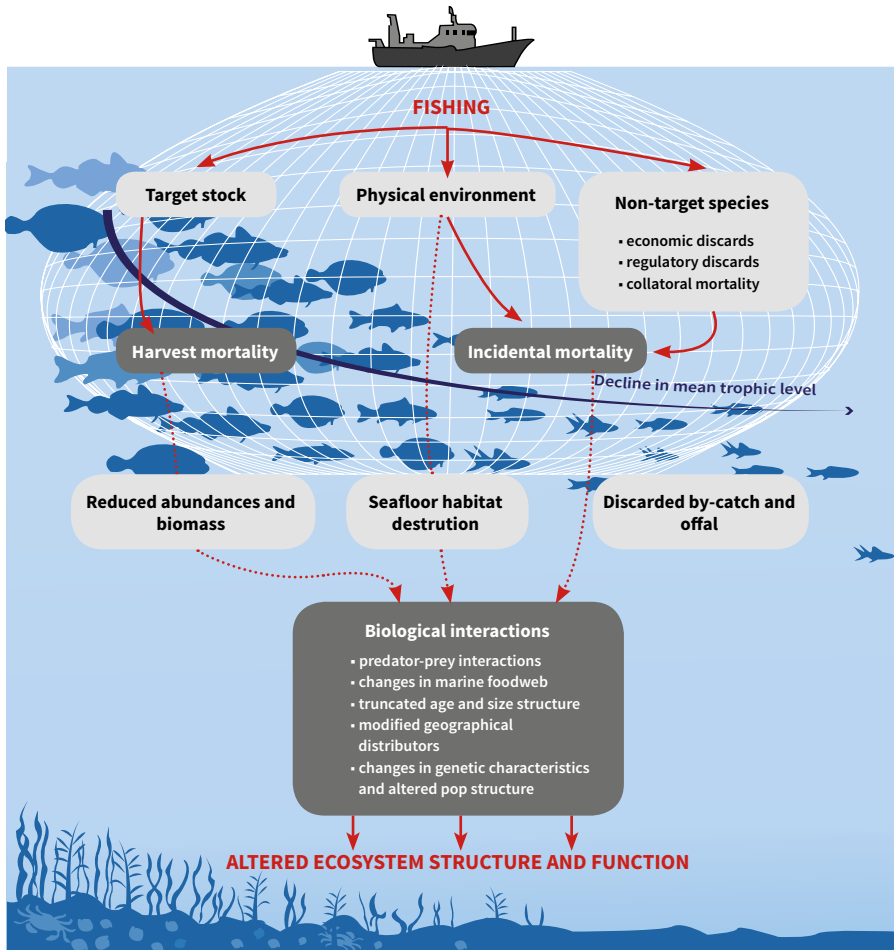

Figure 1 Fishing does not only remove biomass from particular species, but also has indirect effects such as unintended mortality of nontarget species, altering habitat and modifying behavior. It may cause evolutionary shifts in population demography and changes in the function and structure of ecosystems (modified from FAO).

## 2 FOCUS OF THE THESIS

In this setting, the thesis investigates the biology of two commercially exploited flatfish species, turbot (*Scophthalmus maximus*)<sup>1</sup> and brill (*S. rhombus*) in their natural habitat. In a first part of the thesis, I elucidate communalities in the population structure of these two congeneric species by monitoring<sup>2</sup> their genetic variation and investigate the possibilities of extrapolating knowledge of well-studied, closely related species, to data-limited<sup>3</sup> species.

In a second part of the thesis, I will discuss how scientific results may influence management strategies of the exploited marine ecosystem. At the writing of the thesis, a major reform of the EU fisheries management is in progress: the Common Fisheries Policy (CFP). This reform will not only influence the political setting of how fisheries is managed, but has also led to increased scientific know-how. For example, new methodologies have been developed by the Exploration of the Sea (ICES), the so-called ‘data limited approach’ to meet the need for quantitative advice for data-limited stocks<sup>3</sup> (ICES 2012a) and information on these data-limited species. As such, the general discussion of the thesis will address first how the results of genetic studies may shed more light on the current status of the stocks of the two species (the effective population sizes, levels of genetic diversity and gene flow) and what type of communalities can be identified on the basis of life history knowledge and environmental forces. Secondly, I will emphasize how these findings can be of importance to fisheries management, as well as the future research perspectives.

The introductory chapter presents the context of the research project and tackles the ideas and methodologies applied throughout the thesis to assess the spatial and temporal genetic structure of turbot and brill. Before I start describing the methodologies, I will briefly elaborate on the different evolutionary responses to changing environments and outline how genetic methods are useful to study these processes in natural populations.

---

1 In the past 50 year, turbot is referred to either as *Scophthalmus maximus* (Linnaeus, 1758) or *Psetta maxima* (Linnaeus, 1758) in the literature. Based on strong evidence obtained from anatomy, molecular and morphological phylogenetic systematics and the ecology of the scophthalmid fishes the use of *Scophthalmus* as the valid name is recommended.

2 For some scientists genetic monitoring is simply the use of genetic data to study demography or more complex evolutionary and ecological processes, whereas for others it implies systematic measurements of population genetic parameters over time. Here we define genetic monitoring as quantifying the short term-temporal and spatial changes in genetic variation using molecular markers.

3 ICES provides advice for more than 200 stocks. For a part of those stocks there is either limited data available on their biology or on their exploitation, or a lack of analytical methods to provide a comprehensive catch advice (ICES 2012a). These stocks have been labelled as “data limited”. Up to and including 2011, ICES provided qualitative advice, like “catches may not increase”.

Further on, I expand on the biology of the study species and explain why they provide a unique opportunity to study the influence of evolutionary processes in a management setting. At the end, I will describe the specific objectives of the thesis.

### **3 MOLECULAR GENETICS AND THE STUDY OF EVOLUTIONARY CHANGE IN THE OCEAN**

#### **3.1 Good reasons for studying the genetic structure of fish populations**

Local intensive harvesting may have a large scale impact, affecting habitat loss and decline in marine fish populations, even if these are not always detected in the short term (Jørgensen *et al.* 2007; Allendorf *et al.* 2008; Bartolino *et al.* 2012; Laugen *et al.* 2014). The intensity of the effects depends on a combination of migration between populations, distribution of predators and prey, and habitat selection.

Local exploitation can be a small-scale active process that reduces local fish densities at the time of harvesting. Irrespective of local abundances and recruitment, the negative effect of harvesting is observed in those areas where the catches are higher or where the recolonization rate is low despite low fishing pressure (Bartolino *et al.* 2012). The latter is especially observed in the marginal areas of the distribution range (Johannesson & André 2006; Bartolino *et al.* 2012). Non-homogeneous spatial patterns of fishing effort have important implications for the expected annual yield under sustainable conditions (Ralston & O'Farrell 2008; Laugen *et al.* 2014). At the same time, the spatial effect of fishing patterns at intra-annual temporal scales has several management consequences (Hilborn *et al.* 2003a; Bartolino *et al.* 2012). This means that in order to maintain the productivity of different stock components, it will be necessary to investigate the true spatial scale of fish populations (Reiss *et al.* 2009; Dann *et al.* 2013; Ulrich *et al.* 2013). Furthermore, genetic monitoring of populations provides a valuable information tool for “seeing the fish”; tracing individual fish back to their area/population of origin (Nielsen *et al.* 2012).

Present day population structure is determined by historical and current demographic patterns and ongoing selection pressures (Hauser & Carvalho 2008; Nosil *et al.* 2009; Bierne *et al.* 2011). Historical events, like the Pleistocene glaciations, forced species to migrate southwards into refuges, or to go extinct. Traditional genetic models predict low genetic diversity in formerly glaciated areas, with a small number of alleles/haplotypes dominating disproportionately large areas, and high diversity including “private” alleles in glacial refugia (Maggs *et al.* 2008).



The genetic differentiation between refuges may be high (Maggs *et al.* 2008). However, depending on the amount of reproductive isolation that evolves after the initial allopatric period, widespread gene flow will ultimately erode divergence (Nosil *et al.* 2009). Ongoing pressures like selection, can promote genetic differentiation in two ways. Firstly, selection can act on specific genomic regions and the regions physically linked to them. Secondly, divergent selection can promote reproductive isolation that causes barriers to gene flow (i.e. ecological speciation). In this case, genome-wide neutral divergence is facilitated through genetic drift (Nosil *et al.* 2009; Bierne *et al.* 2011). Molecular tools are useful, as they allow us to study these evolutionary forces in the wild. However, it remains challenging to distinguish signatures of historical events predating colonization of current habitats from ongoing evolutionary changes. Hence, studying both past and current levels of population differentiation allows us to see how stable these patterns are over time and how quickly they may change in response to human activities.

### 3.2 Neutral population structure and local adaptation

A phenotypic trait is determined by one or several genes which represent the fundamental heritable units. The DNA sequence of a specific gene may not always be exactly the same among individuals, resulting in different variants of that gene. Such alternative variations of a specific gene are called alleles and the number of different alleles can be used as a measure of genetic variation. The different alleles of a specific gene often occur in different frequencies in different populations. As such, specific alleles can be observed between populations of a species in different frequencies. Therefore, genetic variation is distributed both within and between populations.

Genetic variation in populations is created, maintained or lost through four important processes: mutation, genetic drift, gene flow and selection (Hellberg *et al.* 2002; Hauser & Carvalho 2008). In general, mutations tend to occur relatively slowly and are only relevant from an evolutionary perspective (thousands of years). Contrary, signals from genetic drift, although depending on the effective population size ( $N_e$ )<sup>4</sup> (Hare *et al.* 2011), continuously accumulate over each generation between reproductively isolated populations, as the number and types of parental alleles that are passed on to the next generation is determined by chance (Hellberg *et al.* 2002).

---

<sup>4</sup> The number of individuals that actually contributes genetically to the next generation constitutes the effective population size (Hellberg *et al.* 2002)

The smaller the population, the more dramatic the fluctuation of allele frequencies, and the faster the loss of genetic variation (Figure 2, Hellberg *et al.* 2002; Hare *et al.* 2011). Gene flow, on the other hand, reflects migration and leads to increased homogenisation among isolated populations (Figure 2, Hellberg *et al.* 2002). The maintenance of contemporary neutral population structure mainly depends on the balance between gene flow and genetic drift acting over ecological time scales (Hellberg *et al.* 2002; Hauser & Carvalho 2008). While the former two processes are considered neutral and expected to exert genome wide effects, selection is expected to affect selected gene(s) and closely linked genomic regions, which will show either increased (divergent selection) or reduced (balancing selection) levels of differentiation compared to neutrally evolving genetic sites (Nosil *et al.* 2009).

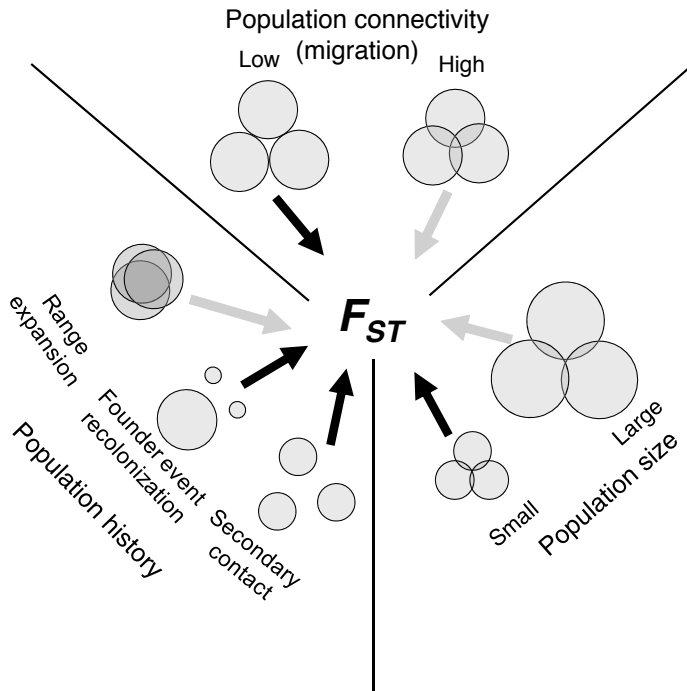

**Figure 2** Factors influencing genetic population differentiation (Hauser and Carvalho 2008). Grey arrows indicate factors reducing strong differentiation; black arrows indicate factors promoting differentiation. Selection is not considered.

Evolutionary processes in the past have shaped contemporary genetic variation in extant species and populations in order to optimize their relative fitness within their natural environments (Nielsen *et al.* 2009b; Nosil *et al.* 2009). As such, environmental pressures will continue to exert selective pressures on local populations in order to continuously optimize fitness in a changing habitat through evolutionary responses based on standing genetic variation. The appearance of advantageous traits will thus develop over time through selective responses to changing environments (Nielsen *et al.* 2009b). In order to detect signals of local adaptation, a well described neutral background of spatio-temporal population structure is of paramount importance to both evaluate the potential for local adaptation to occur (Waples & Gaggiotti 2006; Hansen *et al.* 2012) and as a background upon which loci underlying selective pressures can be detected (Storz 2005). Subsequently, the lack of detectable neutral population structure does not necessarily preclude reproductive isolation between populations, which might be observed at genes under selection (Hemmer-Hansen *et al.* 2007a; Nielsen *et al.* 2009a; Hansen *et al.* 2012).

## 4 BY-CATCH SPECIES IN THE BEAM-TRAWL FISHERY

### 4.1 Demersal fishery

In the inshore waters of the Northeast Atlantic Ocean, demersal fisheries usually target either a mixture of roundfish species, like cod (*Gadus morhua*), haddock (*Melanogrammus aeglefinus*), and whiting (*Merlangius merlangus*), or a mixture of flatfish species, such as plaice (*Pleuronectes platessa*) and sole (*Solea solea*), with a by-catch of roundfish. Other species like brill, turbot, rays (Rajidae), anglerfish (*Lophius* spp.), gurnard (Triglidae), lemon sole (*Microstomus kitt*) and many others, are caught in the demersal fishery as by-catch. Which means that although they are not immediately targeted during this fishery, they are kept on board as they have an economic value. In Europe, plaice and sole are the most important species of the demersal fishery. Although dab is common, its economic value is limited in contrast to the less common but highly priced turbot and brill. Dutch, German and Belgian cutters used to fish for flatfish primarily with the beam trawl, which is an active fishing method towing nets over the seabed with a horizontal beam to keep the net open (Figure 3).

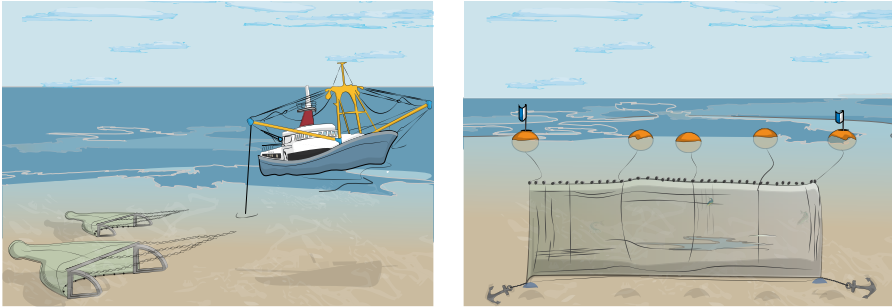

**Figure 3 Demersal fishing methods: left is the beam trawl and right is a passive fishing methods like gillnets**  
© ILVO

As well as the heavy fuel cost, the beam trawl fishery is characterized by several ecosystem impacts including: (1) catches of overexploited species like cod and rays (Poos *et al.* 2010; Ulrich *et al.* 2011), (2) substantial by-catch of undersized commercially important fish (Kraak *et al.* 2008; Poos *et al.* 2010), (3) the impact on benthic invertebrates and habitats by the fishing gear (Jennings & Kaiser 1998; Hiddink *et al.* 2006) and (4) fisheries-induced evolutionary changes in a range of species such as plaice, cod and sole (Allendorf & Hard 2009; Heino & Dieckmann 2009; van Walraven *et al.* 2010; Jakobsdóttir *et al.* 2011). A related fishing method widely used in the demersal North Sea fisheries is otter trawling, which differs from beam trawling in that the horizontal spread of the net is ensured through the hydrodynamic force exerted on the otter doors. Hence, its main advantage compared to beam trawling is reduced water resistance and less contact with the seabed, resulting in reduced fuel costs and ecological damage (Stouten 2010). Finally, passive fishing is a collective name grouping the fishing methods where the fish comes “voluntarily” to the gear (Figure 3). The main advantages of passive fishing, such as by trammel and gill netting, is excellent fuel efficiency, low seabed impact and high selectivity (Stouten 2010).

## 4.2 The biology and fishery of turbot and brill

Turbot and brill are two flatfish species caught in the demersal fisheries as by-catch. Over the period 1973-2008, total landings of turbot ranged from 3504 tons to 9361 tons per year in the Northeast Atlantic Ocean. The lowest landings were reported in the mid eighties and the highest peak in the early nineties. In the last decade, the total landings of turbot have fluctuated between 5000 and 6500 tons. Catches of brill are considerably lower than turbot as on average, they fluctuate around 1000 to 1600 tons.

In the last decade, brill landings slightly increased and varies around 2236 tons (Eurostat, 2011;© European Union). For both species, the North Sea accounts for the major part of these landings, where The Netherlands contributes between 50 and 60% of all landings (Figure 4 and Figure 5). More specifically, most of the landings come from the Southern and the German Bight.

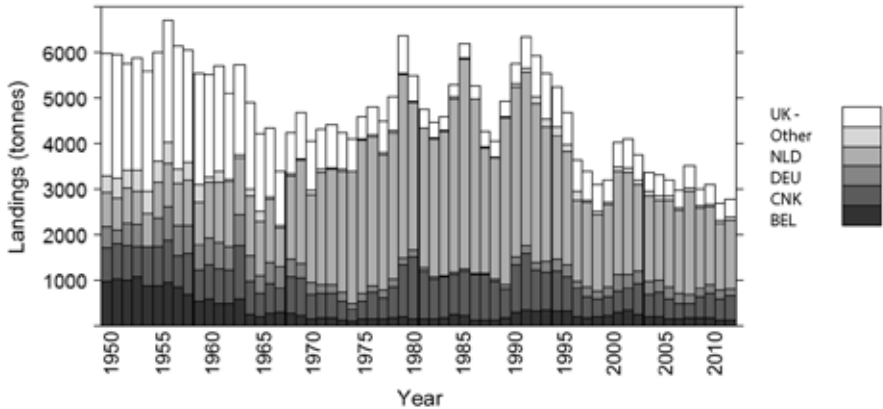

Figure 4 Total international landings of turbot in the North Sea (source: Eurostat database)

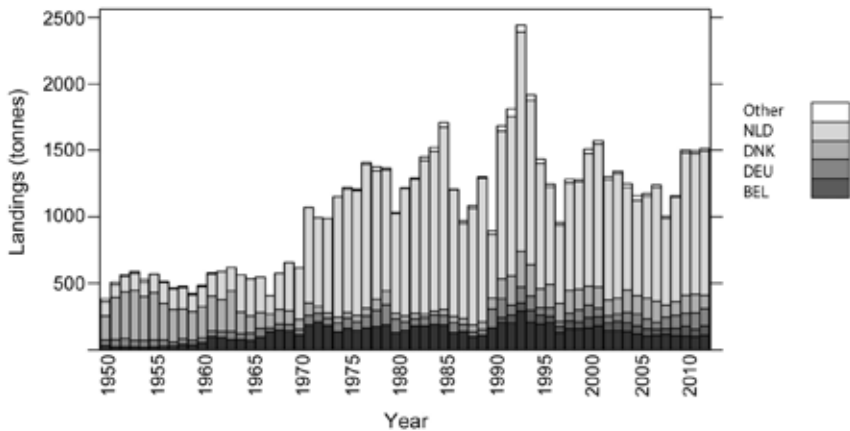

Figure 5 Total international landings of brill in the Greater North Sea (IIIa + IV + VIIde) by country over the period 1950-2010 (source: Eurostat database)

The low abundance and subsequent catches of turbot and brill made fisheries managers put less effort in collecting data and proposing an analytical assessment methodology. Consequently, until 2012, no analytical assessments leading to fisheries advice was carried. Currently, Total Allowable Catches (TACs) have been defined for turbot and brill combined in the Skagerrak and North Sea EC-waters. This combined TAC has declined from 9000 tons in 2000 to 4600 tons in 2012. The advice was generally phrased in terms of “reducing catches”. However, with the new CFP, both ICES and the EU have committed towards an analytical assessment of all European fish stocks (see Part II for more details, ICES 2012a). Despite the limited data-availability on both species, an historical analysis of survey data has shown that the biomass of turbot in the Skagerrak has declined about 86% since 1925, with a decrease in maximum individual body size by 20 cm compared to the beginning of the time-series ( $L_{\max} 1920 = \pm 50$  cm) (Cardinale *et al.* 2009). In the North Sea, a stable abundance or even an increase in the Dutch survey trends have been observed in recent years (ICES 2012b). The fisheries data shows that the distribution range of both turbot and brill is very similar and covers the entire Northeast Atlantic Ocean, from the Iberian Peninsula to the Arctic Circle (30° to 70°N; 23°W-42°E), inhabiting sandy and rocky bottoms from the sublittoral down to at least 70-80 m (Gibson 2005). The North Sea forms their core habitat area, with a slightly higher abundance in the southern and eastern part (ICES 2010; Kerby *et al.* 2013). Although the phenotype and life-history of brill is highly similar to turbot, they are not found around the coast of Iceland and rarely occur North of Bornholm in the Baltic Sea (Nielsen 1986). Flatfishes all over the Northeast Atlantic Ocean, including turbot and brill, show annual micro- and macroscale movements and migration between spawning, feeding and wintering areas (Gibson 1997; Metcalfe *et al.* 2006). The depth distribution of fish is size and age dependent; young fish prefer shallower water, while larger fish is found in deeper waters (Gibson 1997). Species like sole, plaice and flounder (*Platichthys flesus*) have shown to use selective tidal transport in the North Sea (Gibson 1997; Jager 1999; Hunter *et al.* 2004; Metcalfe *et al.* 2006). In spring, both turbot and brill move to their spawning grounds (see below). Daily movements are observed; for example juvenile turbot show diurnal<sup>5</sup> movement, approaching the shoreline during night, supposedly to forage (Stottrup *et al.* 2002). Tidal streams and oceanographic features are also presumed to have a large effect on larval distribution (Gibson 1997; Hufnagl *et al.* 2012; Lacroix *et al.* 2012).

---

5 This migration occurs daily when organisms move up to shallow waters at night and deep waters during the day. There are many hypothesis as to why organisms would vertically migrate and several may be valid at any given time. These hypotheses involve: predator avoidance, metabolic advantages, dispersal and transport or avoidance of UV damage.

This is more plausible as eggs of turbot and brill are pelagic (except for turbot in the Baltic Sea (Nissling *et al.* 2006)). Similar to other flatfishes, turbot and brill begin their lifestyles as symmetric fish larvae with eyes placed in normal positions and an upright swimming mode. A substantial alternation in morphology, physiology and ecology occurs when the juvenile switches from a pelagic, plankton feeding state to a benthic, benthos feeding lifestyle (Yamashita *et al.* 2001). In summer and autumn the juvenile fish dwell in the coastal zone (Gibson 1997).

Although little is known about the location of the spawning grounds of turbot and brill, research on turbot shows that they spawn in shallow waters in the Baltic Sea (10-40 m) and show signs of spawning site fidelity (Florin & Franzen 2010). Taken together with the rather sedentary adult life style, turbot life history characteristics makes the presence of different biological units likely. So far little is known on the life history traits of brill. The only know records for brill on a spawning location has been in Hurd Deep, a trench in the Western English Channel (Delbare & De Clerck 1999). The diversity of life-history strategies of turbot across its range suggests local adaptation and population subdivision. Although both turbot and brill occupy a similar range and display similar life history traits, the research conducted in this thesis has to point out whether one may extrapolate biological knowledge from one species to another very similar sister species.

## **5 APPLIED TOOLS TO STUDY THE GENETIC VARIATION OF BRILL AND TURBOT**

### **5.1 Genetic markers of the nuclear and mitochondrial DNA**

Molecular markers for inferring population connectivity and isolation can be grouped into two categories: frequency markers and sequence markers (Hellberg 2009). Frequency markers derive their power from frequency arguments: alleles that are relatively rare overall but common in a few populations suggest that these populations are connected by gene flow. Associations between alleles at physically unlinked loci (in linkage disequilibrium) can also be used to infer recent exchange and isolation (Pritchard *et al.* 2000). In extreme cases, parent-offspring (Jones *et al.* 2005; Jones *et al.* 2010) and sibling (Selkoe *et al.* 2006) relationships can be ascertained with high probability. Microsatellites are the primary codominant frequency markers used today. They are short tandem repeats of 1-6 nucleotides; alleles are distinguished by varying number of repeat units (i.e. total length).

Although it is well known that some microsatellites occur within genes or are part of upstream regulatory elements, they are generally expected to be embedded in non-coding sequence and of no functional effect, therefore reflecting effects of neutral evolutionary forces and demographic history (Beebee & Rowe 2008). However, if a microsatellite locus is linked to a proximate functional locus, it may be subject to hitchhiking selection, which can substantially bias analyses based on assumptions of neutrality (Luikart *et al.* 2003; Nielsen *et al.* 2006).

Sequence markers, in contrast, derive their power from the ability to infer relationship between alleles (Hellberg 2009). To date, mitochondrial DNA (mtDNA) has been the sequence marker of choice in population genetic studies. MtDNA is haploid<sup>6</sup> and only maternally inherited. Because of the lack of recombination, each haplotype has only one ancestor in the previous generation. Therefore, the effective population size is four times smaller than nuclear DNA and is thus more susceptible to random genetic drift. Haplotype frequency differences between populations can be created in a relatively short time. Nucleotide polymorphism is considered mainly neutral and thus more influenced by populations demography than by selection. For this reason, mtDNA is a widely marker in phylogeographic studies (Beebee & Rowe 2008; Galtier *et al.* 2009).

## 5.2 A new era in marker development

While classical population genetic studies apply no more than ~20 markers for inferring population patterns, population genomics use genome-wide sampling of at least 100 to 1000s of markers to disentangle locus-specific effects like selection from the genome wide influence of genetic drift and gene flow (Luikart *et al.* 2003). Recent improvements in the speed, cost and accuracy of next-generation sequencing (NGS) are revolutionizing the opportunities for generating genetic resources in non-model organisms (Hudson 2008; Hauser & Seeb 2008, Helyar *et al.* 2010). The traditional Sanger and NGS protocols both mechanically shear the target DNA into fragments. However, where Sanger sequencing requires sub-cloning of each DNA fragment, NGS techniques like 454 GS FLX Titanium technology (“454 sequencing”) uses fragmented DNA directly. This avoids producing a cloned shotgun library (Wicker *et al.* 2006). One drawback of NGS at the time of writing is the shorter length of sequence reads and lower base calling accuracy.

---

<sup>6</sup> A haploid cell is a cell that contains one complete set of chromosomes present in one copy per organism.



For the rapid development of genetic markers such as microsatellites or SNPs, high-throughput sequencing is ideal, given that sufficient reads are produced and assembled to yield good coverage (Toth *et al.* 2007; Hudson 2008). For microsatellite development, deep coverage is not even needed, as repeat sequences can be identified in one read of sufficient length (> 300 bp). This contrasts with SNPs, which require a higher sequencing depth<sup>7</sup>. As such, the longer reads generated by 454 sequencing are better suited for microsatellite development in non-model species (i.e., those lacking a reference genome), compared to the shorter reads from competing technologies (average of 100-150 bp)<sup>8</sup>. The additional information on flanking region polymorphism based on longer reads is preferable to avoid mispriming and thus null alleles. The commonly performed pre-selection step of specific repeat motifs (SSRs) is usually not necessary, given the broad distribution of SSRs in the genome, the ever-increasing number of sequence reads and the importance of random sampling of microsatellite loci across the genome without motif selection.

Here, high-throughput 454 sequencing (454 GS FLX Titanium sequencing, Roche) was applied starting from genomic DNA to detect novel microsatellite loci in brill and test cross-amplification in the related turbot. Results have been published in (Molecular Ecology Resources Primer Development *et al.* 2012). The novel microsatellite markers are applied for the assessment of genetic connectivity between brill stocks in the comparative population genetic study described in Chapter 4.

### 5.3 Seascape genetics

The field of landscape genetics aims at combining information from the surrounding “landscape” (i.e. geographic location and environmental parameters such as temperature, salinity and habitat type) with patterns of genetic variation among populations (Manel *et al.* 2010; Dray *et al.* 2012).

---

<sup>7</sup> Depth of sequencing is generally calculated as the number of genome equivalents that must be sequenced, with 1× coverage referring to the sequencing of one genome equivalent, 2× of two genome equivalents and so on. The required depth for either *de novo* sequencing or resequencing is always much greater than 1×, and depends on many factors, chiefly sequence read length, sequence quality and for some applications, whether mate pairs are available.

<sup>8</sup> More sequence depth is always an advantage, since it allows better coverage of rare mRNA sequences. Conversely, even a relatively small, inexpensive amount of next-generation sequencing can produce the sequence of several thousand genes from an organisms with no existing genomic resources (Toth *et al.* 2007). Very short read technologies such as Illumina or Solexa may not allow effective *de novo* assembly of transcripts that are not deeply covered or do not have a closely related template as well as longer read technologies such as 454.

As the name suggests, these methods have originally been developed for terrestrial systems. Meanwhile they have found great use in aquatic systems as well (Selkoe *et al.* 2008; Selkoe *et al.* 2010; Orsini *et al.* 2012). Commonly used statistical methods in community ecology like redundancy analysis (RDA) and related multivariate methods promise to be powerful tools. These methods allow both to investigate how environmental factors correlate with natural genetic variation (e.g. identify possible barriers that limit gene flow), as well as to couple surrounding landscape variables to functionally important genetic variation involved in local adaptation of wild populations.

RDA allows to predict values of a multivariate set of response variables (genetic variation) based on the predictor variables (space and environment), taking into account covariation in both predictor and response variables. RDA does this by maximizing the variance explained in the response variables by the predictors and creates orthogonal axes of linear combinations of response and predictor variables. The variance in response variables accounted for by predictor variables can be partitioned into components attributable to climate, space and climate–space confounded.

We used this seascape genetic approach to test for associations between environmental parameters and temporal and spatial variation in allele frequencies. The underlying principle here is that strong correlations can suggest selection driven by particular environmental variables (or correlated factors) and hence help generate hypotheses about causative agents for observed patterns (Joost *et al.* 2007; Coop *et al.* 2010; Manel *et al.* 2010). These methods have contributed fundamental knowledge on which factors are likely to drive local adaptation and the spatial scale at which divergent selection operates in the wild. However, teasing apart the mix of potential causes across both the species geographic range and its genome presents an analytical challenge because of the high dimensionality of the system (Tonsor 2012). Nevertheless, results from these approaches still serve a useful hypothesis generating role.

## 5.4 A comparative approach to understand historical and contemporary events

To elucidate how contemporary population processes and historical events have acted in mapping organisms' current distribution and genetic structure, comparative studies offer a powerful approach (Hendry *et al.* 2008; Galarza *et al.* 2009a; Blanchet *et al.* 2010). Spatially matched taxa are often expected to show similar signatures of structure based on their shared histories (Zink 1996). For example, several studies have reported concordant patterns of genetic structure in Europe, increasing our understanding of the impact of current and past barriers to gene flow (reviewed in: Hewitt 2004; littoral fish species: Galarza *et al.* 2009a; fruit bats: Chen *et al.* 2010; Primates: Gavilanez & Stevens 2013). Conversely, disparities in genetic structure between co-distributed species may highlight differential responses to these processes often resulting from contrasting life history and ecological traits (Bargelloni *et al.* 2005; Galarza *et al.* 2009a; Wilson & Veraguth 2010). Dispersal ability is a key demographic force shaping natural populations (Proctor *et al.* 2004). Contrasting dispersal strategies, which are often linked to social structure<sup>9</sup>, impact the balance between gene flow, genetic drift, mutation and natural selection (Storz *et al.* 2001; Hoarau *et al.* 2005; Gavilanez & Stevens 2013). It suggests that it should be more straightforward to identify a shared history of habitat fragmentation and subsequently identify common migration barriers for closely related species with a comparable biology (Chen *et al.* 2010). Although I focus mainly on two conspecific flatfish species of the Scophthalmidae (turbot and brill), co-occurring flatfishes are also considered from two additional families, Soleidae and Pleuronectidae. While major challenges remain to understand the primary forces shaping patterns of genetic variability in marine fishes, we aim, through the combination of genetic data and information on seascape characteristics, to obtain further insights into the role played by different drivers shaping their genetic populations structure. Additionally, patterns in life-history traits of several flatfish species are investigated to gain better insight in the degree of correlation between population structure and life history traits.

---

<sup>9</sup> Traits like body size, social structure, microhabitat use and foraging behaviour, allow species to diverge on several axes of their ecological niche (Gavilanez & Stevens 2013). Studies have shown for example strong territoriality and complex mating behaviour including the possibility of female choice in non-commercial flatfish species (Hoarau *et al.* 2005). If it turns that female choice is an important factor in mating, then anything that disrupts this process could have strong effects on fertilization success and population fitness for the local aggregation (Hoarau *et al.* 2005). Spawning site fidelity of e.g. plaice and turbot has been shown (Hunter *et al.* 2003; Florin & Franzen 2010), but how do they know how to find their spawning grounds? A possible explanation would be through larval attachment (natal philopatry), which would promote strong population differentiation. Alternatively, immature fish may accompany mature fish to the spawning ground in order to learn the location and to associate some feature of the mature spawning fish (Arnold & Metcalfe 1995).

## 6 OUTLINE AND OBJECTIVES OF THE THESIS

### 6.1 Outline

Fish stocks and populations have focused on a single species concept, a necessary but insufficient approach to fisheries management. Over the few last years, there has been a gradual move towards an “ecosystem approach to fisheries management” (EAFM) as part of sustainable environmental management (Rice 2011). Populations and species are embedded in collections of species, communities and ecosystems, which are the natural units of management (Waples & Gaggiotti 2006; Reiss *et al.* 2009). This EAFM is particularly appropriate for shallow seas where flatfish are a key component of demersal communities and may be considered an umbrella taxon<sup>10</sup> (Lambeck *et al.* 1997; Rogers *et al.* 1999). They have evolved a range of ecological and physiological adaptations to benthic environments (Gibson 2005). Their larvae are planktotrophic, postlarvae meiobenthic predators and adults are first and second order carnivores, occupying the middle to upper levels of the food web. They are biologically unique because of asymmetric laterally flattened body shape. Survivorship curves have a negative binomial shape (type III) with a high fecundity and high juvenile mortality, a typical feature of many bony fish.

The main aim of the thesis was the investigation of the population structure of turbot (*Scophthalmus maximus*) and brill (*S. rhombus*), two commercially important species albeit present at low densities. Meeting the new objectives of an EAFM, represents a challenging task for scientists because it requires, amongst others, the integration of new species into the management procedures. The vital steps needed to meet these objectives will be dealt with during the course of this thesis in two main parts. These are discussed below.

---

<sup>10</sup> When making management decisions, we never have all the information we need. One knowledge gap is that we do not know where all species are (or even what they are – so many species remain undiscovered and undescribed). Nor do we know how they will react to changes to their environment including management. So inevitably, we have to use a subset of species as proxies for how biodiversity as a whole will be affected by management (Lambeck 1997; Rogers *et al.* 1999). Such “umbrella” or “focal” species should therefore have habitat requirements that are similar to those of the other species, but they are usually the ones most affected key threats (Nicholson *et al.* 2013). This suite of species can be selected based on life history characteristics, such as dispersal limitation and area requirements.

## ***Part I Can genetics assist with the identification of biological relevant units?***

### *A) Establishing the historical baseline of population structure*

Contemporary genetic population structure and diversity is a result of the combination of present-day and historical processes. Strong fluctuations in climate regime have always characterized the oceans. Glacial events caused ecosystem changes, environmental range shifts, and resulted in adaptation of the populations in these ecosystems, or forced species to migrate southward during cold periods and northward during warmer periods (Hewitt 2004). Cold periods often lead to population reductions with small groups surviving in refuges. The subsequent population reductions and expansions leave genomic imprints of reduced and skewed diversity and generate distinct clades (Hutchinson *et al.* 2003). Studying these historical patterns provides us with initial information for stock delineation (concept of evolutionary significant unit) (Moritz 1994). In addition, these type of results will be crucial to calibrate models which may predict how species will respond to future temperature increases: are they likely to go extinct, move towards more suitable habitat or are they able to adapt?

To uncover the influence of such historical events two mitochondrial DNA markers were genotyped. The strength of this comparative approach lies in the possibility to disentangle the major determinants of population structure of Northeast Atlantic Ocean organisms (cfr. Maggs *et al.* 2008), we may assume that with biological traits being so similar, it should be more straightforward to identify a shared history of habitat fragmentation.

### *B) The interaction between environmental variation and life history traits suggesting restricted movement sheds light on the population structure of a marine species*

As stated above, contemporary genetic structure represents ongoing population connectivity and patterns due to historical phenomena. These ongoing pressures are the results of a balance between dispersal and adaptation to the local environment. Even in an environment of high gene flow, divergence may still be possible provided that differentiating selection is strong (Nielsen *et al.* 2009a; Pinho & Hey 2010; Hansen *et al.* 2012). In this second chapter, the effect of the interaction between current and past processes is investigated on the population structure of turbot. Turbot is a species with a broad range of life history traits, presumably indicating local adaption to the different environmental pressures they are exposed to (Imsland *et al.* 2001a; Vilas *et al.* 2010). Using a rather restricted panel of both anonymous and Expressed Sequence Tags (EST) linked microsatellite loci, the effects of environmental and spatial parameters on genetic variation are disentangled.

As several studies have shown that various topographical, hydrodynamical and behavioral drivers lead to population substructure (Nosil *et al.* 2009; Galindo *et al.* 2010; Knutsen *et al.* 2011), I am interested to what level these features shape gene flow within the populations at a seascape scale. Although these population differences might be small at a neutral genetic level, as population dynamics might be concordant over large areas, they become strong and biologically meaningful once they are interpreted in view of local adaptation (Nielsen *et al.* 2009a; Cadrin 2010; Teacher *et al.* 2013).

### *C) Identifying communalities in flatfish structure and assess the stock status as a base for management*

The impacts of fishing are obvious through increased mortality of target and non-target organisms. However, as most marine species are characterized by large census population sizes, the biomass is never that low that there is an immediate threat for extinction (Dulvy *et al.* 2005). Even after depletion, a stock might still consist of millions of individuals (Branch *et al.* 2012). But there are implications for population viability and resilience due to population fragmentation, inbreeding and loss of genetic diversity. This implies a discrepancy between a stock in commercial terms and a biologically relevant population. 'Stock' is a technical term describing a group of individuals that is under consideration for exploitation and management purposes (Reiss *et al.* 2009). The definition of a fish stock generally includes elements of congruency among individuals such as demographic and phenotypic features<sup>11</sup>. Normally, in fisheries management a group of individuals that are identified as a stock, occupy a well-defined spatial range (fishing area) independent of other stocks of the same species. The term population takes into account the biology of organisms. It describes the collection of individuals of a particular species, which can be defined as a local inbreeding group (more details in: Waples & Gaggiotti 2006; Reiss *et al.* 2009). Such group has reduced genetic exchange (gene flow) with other groups of the same species, meaning that mating between individuals of different groups only rarely occurs. As such, the application of genetic principles and methods to fisheries management are a crucial prerequisite for the preservation of the stocks because genetic biodiversity affects reproductive performance, adaptation to environmental changes and resistance to disease (e.g. Lage & Kornfield 2006; Johannesson *et al.* 2011).

---

<sup>11</sup> Some stocks might not be genetically distinct groups of fish, but simply reflect differences in phenotypic life history parameters in response to environmental variation and fishing pressure. Nevertheless, random dispersal or directed migration due to seasonal or reproductive activity can occur. The reproductive isolation of populations on the other hand leads to sufficient isolation from other groups of individuals from the same species for some level of genetic differentiation to be established (Waples *et al.* 2008)

In this setting, the genetic diversity and substructure of three flatfish species, turbot, brill and sole is investigated. By occupying a similar geographic range but displaying different spawning preferences (Gibson 2005; van der Hammen *et al.* 2013), these species provide an opportunity to determine whether their ecological differences are reflected in the population structure. Further insight is obtained into the drivers shaping their genetic population structure by combining genetic and environmental information. Additionally, by investigating patterns in life-history traits of other flatfish species and their population structure, better insight is acquired in the degree of correlation between population structure and life history traits.

## ***Part II How to transfer scientific knowledge to marine policy?***

The ecosystem-based approach to fisheries management nails the borders of policy issues around a commonly defined ecosystem based area, trying to find and implement knowledge-based solutions. Knowledge for EAFM is by definition drawn from multiple sources and established in an attempt to solve wicked problems<sup>12</sup>. Within the setting of the European commitment to the EAFM, decision makers and scientist face the problem of, amongst other, species for which little data are available. In the first part of this thesis, knowledge was produced to serve as an example for two such data-limited species. Moreover, the influence of these results is tackled in a multi-species management approach. However, it is not only sufficient to produce knowledge for decision making only as policy implementation requires knowledge too. A high frequency and quality of communicating knowledge among administrative levels as well as decision-making actors will be essential. One of the key points in the literature when discussing science-policy interaction and knowledge generation, is that decision makers often simply do not have the information they need (Cash *et al.* 2003; McNie 2007; Kraak *et al.* 2013). This lack of information tends not to be caused by a shortage of scientifically produced knowledge, but rather from the mismatch between the kind of knowledge produced and the kind of knowledge actually needed (McNie 2007; Österblom *et al.* 2011).

---

12 The terms “wicked problems” is used to describe a problem that is difficult or impossible to solve because of incomplete, contradictory, and changing requirements that are often difficult to recognize. Today, so-called ‘wicked problems’ combining scientific uncertainty with societal dispute, challenge traditional ways of policy making and of policy advice (Van Damme *et al.* 2011). Governments are increasingly dependent upon external information, knowledge, expertise and support in order to successfully deliver policies. And whilst seeking policy advice is nothing new in the world, modern democratic governments must contend with these increasingly complex policy topics combined with increasing scrutiny from a population where media embedded interest groups, and even individual citizens, can monitor every decision taken (Van Damme *et al.* 2011).

Targeting the problem of knowledge utilization requires a basic know-how of the fisheries management system and the associated problem and challenges faced in sustainable management of the fisheries. In the second part of this thesis I like to address these needs and solutions.

Initially, I introduce the problem of overfishing and its ecological and socio-economic implications. The international legal framework that addresses overfishing is described in its main components, principles and rules relevant for European Fisheries Management (see Chapter 5). As clearly stated by these agreements, scientific research should form the crucial basis for any sustainable fisheries management. Within this chapter the flow of scientific information under the current CFP is illustrated. The Commission receives scientific advice from its Scientific, Technical and Economic Committee for Fisheries (STECF), which in turn depends to a great extent on advice from ICES regarding biological issues for the Northeast Atlantic Ocean, North Sea and Baltic Sea. All European States have major sampling and data collection programmes in place, which are collated by ICES to evaluate catches and landings for research purposes, stock assessments and long-term proposals on how fisheries can be managed sustainably.

In turn, the European fisheries regime is implemented domestically by means of legislation, enactments and tools set out to achieve the European objectives (see Chapter 5). The domestic implementation of these international regimes tends to jeopardize the success of fisheries management (Brans & Ferraro 2012). Taking this together with the fact that communication between all levels of administration plays an important part, the main actors are described in the policy setting of Belgian Fisheries management (see Chapter 5). Europe's commitment to adapt an EAFM in the current Common Fisheries Policy will affect all stakeholders. As such, some of the changes in the science and advisory processes that might be needed in support of the CFP reform and the adoption of an EAFM are described in Chapter 6.

Chapter 7 presents in more detail some of the pitfalls associated with the complexity of European and global fisheries management. As most ecosystems are affected by human activity, ecological understanding itself is not sufficient to answer such human centered question, which implies a role for policy related knowledge. In this perspective, the implementation of genetic research results raises additional difficulties.



The time frame over which fisheries or climate related changes induce genetic changes unfolds over decades, which is significantly longer than the time frames most often considered in conventional fisheries management (Rice 2011). Nevertheless, it will ultimately influence the utility of the stock (Laugen *et al.* 2014; Heino *et al.* 2013). Therefore protecting genetic diversity trades off against short-term gains in yield, and this potentially generates conflicts of interest among stakeholders. Managers will thus have to balance long-term gains against short-term losses when maximizing yields over long time spans (Dankel *et al.* 2012; Laugen *et al.* 2014). In the end, these trade-offs will have to be implemented in the reference points, because they are key quantities in fisheries management, as illustrated by their pivotal role in harvest control roles, especially in setting total allowable catches and technical measures (Jørgensen *et al.* 2007; Laugen *et al.* 2014).

As a result there is not only a need for more sound science, but also for specific and other knowledge related to specific practices, and for procedures to deal with uncertainties. As such, I discuss where scientific information is lacking for the management of commercial stocks, namely in the consequences of trade-offs among objectives, interaction between fisheries and other human activities affecting the same ecosystem components and attributes, interaction between inshore and offshore fisheries, environmentally responsible fisheries, integration of fisheries and environmental management and maintaining effective management in a changing climate.

As ecological scientists, we are well aware that these are troubling times. During the last decades, the public has become aware of the current environmental crisis. Yet, most do not actively engage in behavioral change. The last chapter discusses how science communication can be made more effective and highlights that scientists, despite the lack of sufficient knowledge, should partake a more active role in policy debates, and engage a wider sector of society such that real-world problems are understood and may be resolved.

## 6.2 Research questions

Building on the consideration presented in this chapter and summarized above, the research is conceived as an attempt to answer the following set of questions

### *Question Part I*

***To what extent can genetics assist in the identification of biologically relevant management units?***

- 1 A. How important are historical processes in shaping the present day population structure of fish?
- 1 B. Is the effect of spatial or environmental variation, most important on the genetic variation of a marine fish?
- 1 C. To what extent do life history traits and environmental variables reflect spatial structure in flatfish species and do these spatial substructures affect the levels of genetic diversity?

### *Question Part II*

***How to transfer scientific knowledge to marine policy?***

- 2 A. How is fisheries policy structured within an international and European framework?
- 2 B. Have these management strategies been successful?
- 2 C. What are the main challenges policy makers, stakeholders and scientists are faced with?
- 2 D. What is the role of science within fisheries policy?

The first group of questions are answered based on a specific case study of the European demersal fishery, which develops along two dimensions: (1) What is the status of the within species diversity and (2) Can we find commonalities between species which would allow to extrapolate knowledge of well-studied species onto data-limited species.

The second group of questions aims to enrich the scientific awareness of knowledge production and how the results of research can be effectively implemented in the policy arena. Understanding the obstacles and challenges faced for a correct implementation allows to define what should be changed to fill this implementation gap (Hill & Hupe 2002).

# Part I

Foto: © Kevin Vanhalst





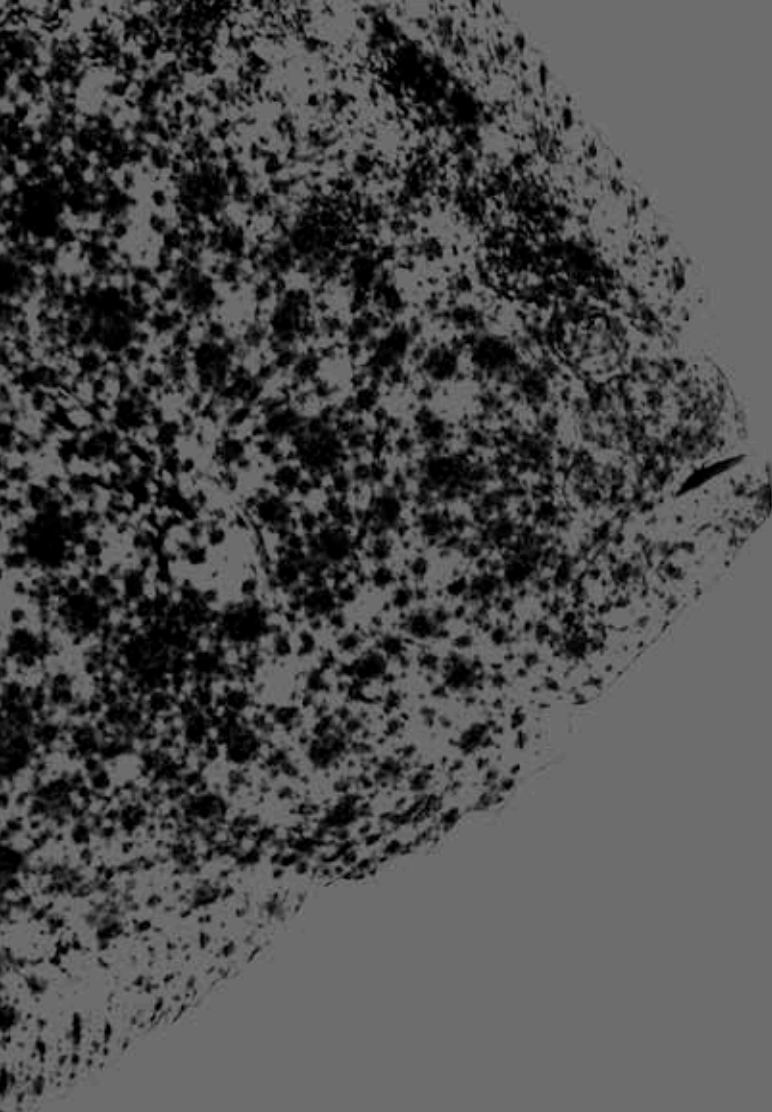

# Chapter 2

## Demographic history of turbot and brill

Foto: © Hans Hillewaert



# Chapter 2

## Colonization history of two sympatric sister species, *Scophthalmus rhombus* and *S. maximus* (Teleostei, Scophthalmidae), across the Northeast Atlantic Ocean

Vandamme S.G., Larmuseau M.H.D., Coscia I., Vanhove M, Pincheel T, Maes G.E.M., Hellemans B., Khanaychenko A, and Volckaert F.A.M.

### ABSTRACT

Comparative phylogeographic studies have revealed dissimilar evolutionary histories. However, these discrepancies may be attributed to the comparison of co-occurring species that are not closely related or species that display an allopatric speciation. Here, we investigated the impact of the evolutionary history on two sympatric sister species: turbot and brill. This should allow us to reliably attribute the combined effects of gene flow and phylogeographic structure on the present day population structure. Using the mitochondrial cytochrome *b* and cytochrome oxidase I gene sequences, we first evaluate the taxonomic relationship between Atlantic and Black Sea turbot lineages. Our results confirm morphological and biological studies concluding their conspecificity. Colonization history across the European waters was investigated using Approximate Bayesian Computation. Results indicate that Black Sea turbot diverged from the Mediterranean and Atlantic populations before the last glacial cycle. Overall, brill appears to have diversified earlier than turbot, but the first differentiation happened between the Atlantic and an unsampled Mediterranean group. Within the Northeast Atlantic Ocean both species display shallow phylogenetic structure indicating recent recolonization events and high dispersal ability. Therefore, the homogeneous distribution of genetic variation in Atlantic brill implies there are no species-specific traits or on-going selection pressures to overwrite the historical effect. This is in contrast to turbot where present-day population structure must result from the interaction of gene flow, natural selection and species-specific life history traits.

## INTRODUCTION

Turbot (*Scophthalmus maximus*) and brill (*S. rhombus*) are sympatric demersal fishes living in coastal waters within the Northeast Atlantic Ocean, the Mediterranean and the Black Sea (Bailey & Chanet 2010; Giragosov *et al.* 2012; van der Hammen *et al.* 2013). Both species are economically highly valuable (Danancher & Garcia-Vazquez 2011; van der Hammen *et al.* 2013) in fisheries and aquaculture, mainly concentrated in the Atlantic area. Despite their commercial value and growing aquaculture interest, many aspects of their biology remain unknown. This is particularly worrying given that a correct management of biological resources should be grounded on the most complete information about natural genetic diversity (European Council 2013; Moritz & Potter 2013).

Scientific interest in these two species increased over the past five years (Cardinale *et al.* 2009; Kerby *et al.* 2013; van der Hammen *et al.* 2013). Although turbot and brill are sympatric sister species, there are some small discrepancies between them. First, subtle differences in their distribution suggest that the two species differ in their ecophysiology, for instance in their thermal and salinity preference, with turbot being more eurytopic (wider distribution in Baltic Sea, northern North Sea and Black Sea, see Figure 1) (Stankus 2003; Florin & Hoglund 2007; van der Hammen *et al.* 2013). Second, previous population genetic studies showed that brill has an almost panmictic structure (Bouza *et al.* 2002, chapter 4), while there are clear signs of population subdivision in turbot (Nielsen *et al.* 2004; Vilas *et al.* 2010; Vandamme *et al.* 2013). Third, having nearly identical life history and biological traits, except the onset of spawning (see Table 1), we believe that the first two observations are the most important to explain possible discrepancies in their demographic history. Discrepancies in closely related species have been observed before (ChARRIER *et al.* 2006; Campo & Garcia-Vazquez 2010; Sá-Pinto *et al.* 2012) and may reflect both vicariant effects of earlier Plio-Pleistocene patterns of oceanic circulations and physical barriers, and contemporary gene flow modulated by hydrodynamical parameters and ecological traits of the species (Grant & Bowen 1998; Bierne *et al.* 2011). At the same time, these studies highlight the difficulties to separate the impact of ecological and historical factors in the present-day genetic structure. Hence, investigations on the factors affecting historical gene flow must 'control' for such historical events by comparing species that differ minimally in both range and phylogenetic history, i.e. sympatric sister species (Dawson *et al.* 2002). Indeed, differences in the phylogeography of such sympatric species should be attributable to recently derived, species-specific characteristics.



However, before reconstructing their historical demographic history, we should evaluate first the taxonomic status of the Black Sea turbot. The taxonomic status of turbot in general, has been a topic of debate for years. Although the monophyletic status of *Scophthalmus* has been confirmed in both morphological (Chanet 2003; Voronina 2010) and molecular studies (Meynard *et al.* 2012; Betancur *et al.* 2013), two generic names, *Psetta* and *Scophthalmus*, are in use since 1839 (Bailey & Chanet 2010). At the moment *Scophthalmus* is considered to be the valid genus name (Bailey & Chanet 2010). Although morphological and biological traits suggest the conspecificity of Atlantic and Black Sea *S. maximus* lineages (Voronina (2010)), phylogenetic support is currently lacking due to insufficient resolution of previous studies (Chanet 2003).

In contrast to previous studies classical phylogenetic and phylogeographic markers (Meynard *et al.* 2012; Betancur *et al.* 2013), such as the mtDNA cytochrome *b* (*cytb*) and cytochrome oxidase subunit I (COI), were applied in combination with an extensive sampling scheme across their distributional range to (a) investigate the sister taxon relationship of Atlantic-Mediterranean turbot and Black Sea turbot within the monophyletic Scophthalmidae (Chanet 2003; Pardo *et al.* 2005; Voronina 2010) and (b) to explore the relative importance of historical processes in shaping the present-day genetic structure of these coastal fish species. Climatic oscillations during the Pleistocene induced successions of population regressions and expansions that may be reflected in the contemporary genetic structure of marine species (Maggs *et al.* 2008; Wilson & Veraguth 2010). Slight differences in the thermal and salinity preferences implies that divergent demographic events and colonization schemes might have affected the genetic structure of these two species differently (Charrier *et al.* 2006; Almada *et al.* 2012; Briggs & Bowen 2012). The use of the same markers and sampling design to survey population genetic variation, warrant optimal comparability across species.

## **MATERIALS AND METHODS**

### **Collection of material and sequencing protocol of *cyt b* and COI sequences**

A total of 360 *S. maximus* and 249 *S. rhombus* (Scophthalmidae; Teleostei) individuals were caught at respectively 21 and 16 locations along the European coast in 2009 and 2010 (Table 2, Figure 1). Fin tissue samples were taken during research surveys or onboard sampling on commercial vessels and preserved in 96% ethanol. Genomic DNA was extracted using the Nucleospin extraction kit (Macherey Nagel GmbH, Düren, Germany).

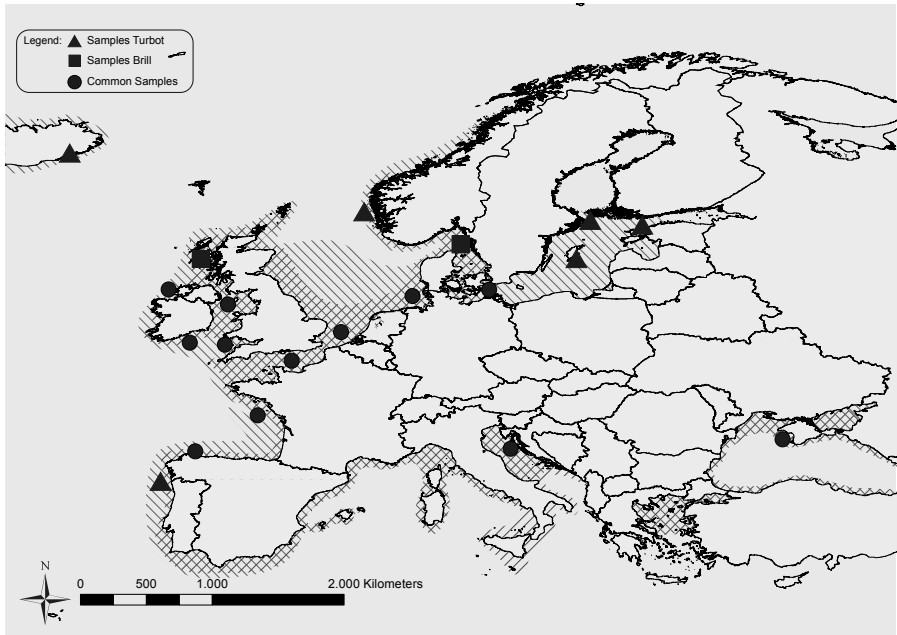

**Figure 1** Distribution range of turbot (left hatched lines) and brill (right hatched lines) across the Northeast Atlantic Ocean. Sample locations of both taxa are represented by a dot, unique samples for turbot are illustrated by a triangle and for brill a square was used.

From each sample, a fragment of the mitochondrial DNA (mtDNA) locus cytochrome *b* (*cytb*) was amplified by PCR using the universal primers *cytb*16F (5' TCCTCAGTAG-ACAACGCCACCCT 3') and THR-fish-R (5' ACCTCCGATCTTCGGATTACAAGACC 3') for turbot (Sevilla *et al.* 2007). For brill, a species-specific forward primer was designed using Primer3 v 0.4.0 (Koressaar & Remm 2007): 3BLLF (5' ACGCCCTCGTACAATGAATC 3'). PCR conditions were: initial denaturation for 3 min at 95 °C, followed by 35 cycles of denaturation for 30 s at 95 °C, annealing at 50 °C for 35 s, and extension at 72 °C for 1 min, followed by a final extension step at 72 °C for 7 min. However, amplification of the *cytb* fragment turned out to be a challenge, which is a common feature of homologous mtDNA gene fragments in several other monophyletic fish groups (Kocher & Stepien 1997; Hoarau *et al.* 2002; Espiñeira *et al.* 2008). Therefore, instead of trying to amplify the full *cytb* sequence for so many samples, we opted for the inclusion of a second mtDNA gene fragment, the mitochondrial locus cytochrome oxidase subunit I (COI). Despite its lower variability, it has proven successful to establish phylogenetic relationships (Espiñeira *et al.* 2008; Meynard *et al.* 2012). The COI gene was sequenced using universal primers COI-ff2d-fish (5' TTCTCCACCAACCACAARGAYATYGG 3') and COI-fr1d-fish (5' CACCTCAGGGTGTCCGAARAA CARAA 3') (Ivanova *et al.* 2007).

PCR cycling parameters were: denaturation of 3 min at 95 °C followed by 35 cycles of 30 s at 95 °C, 30 s at 52 °C and 45 s at 72 °C, with a final extension step of 7 min at 72 °C. Both PCR reactions were performed in a 40 µl total volume containing 2 µl of extracted DNA, 4 µl of each primer, 10 µl water and 20 µl Red Taq DNA polymerase Master Mix (VWR). This mix contains 0.4 mM dNTPs, 1.5 mM MgCl<sub>2</sub>, 0.05 units/µl Ampliquon Taq DNA polymerase and 2x reaction buffer. PCR amplifications were performed with a *BIOMETRA T-PROFESSIONAL 96* gradient unit (Biometra). Sequencing reactions were performed using the ABI PRISM BigDye Terminator cycle sequencing kit at the VIB Genetic Service Facility using a 96-capillary 3730xl DNA Analyzer. Sequences were edited using SeqScape v 2.5 (Applied Biosystems), aligned with CLUSTALW and then refined by eye in MEGA v 5.1 (Tamura *et al.* 2011). To establish phylogeny within *Scophthalmus*, our dataset was completed by adding sequences of all other species belonging to this family: *S. aquosus*, *Phrynorhombus norvegicus*, *Lepidorhombus boscii*, *L. whiffiagonis*, *Zeugopterus punctatus* and *Z. regius* (See Table S1 for GenBank Accession Numbers). *Solea solea* (Table S1) was added as outgroup, as this species was identified as sister group (Pardo *et al.* 2005; Azevedo *et al.* 2008; Betancur *et al.* 2013). We did not want to choose a too distantly related species as this may force a monophylogeny of the family Scophthalmidae (Meynard *et al.* 2012).

**Table 1 Life history traits of turbot (*Scophthalmus maximus*) and brill (*S. rhombus*)**

Species	<i>Scophthalmus rhombus</i>	<i>Scophthalmus maximus</i>
Adult depth distribution (m) <sup>1,2</sup>	70-80	70-80
Spawning location <sup>*3,4</sup>	Offshore	Offshore
Spawning time <sup>6,7</sup>	February-August	May-July
Nursery <sup>8,9</sup>	shallow coastal waters	shallow coastal waters
Average fecundity (eggs/g) <sup>6,7,10,11</sup>	103 -465	430-1078
Periodicity <sup>12</sup>	17 batches in total, one every 3.8 days	12-16 batches in total, one every 3.3-3.7 days
Egg size (mm) <sup>6,7</sup>	1.28-1.65	0.9-1.2
Maturity (y) <sup>4,13</sup>	3	3
Larval duration (days) <sup>6*</sup>	61	68
Settling size (mm) <sup>6</sup>	25	23-39

\* In the Baltic, turbot spawns in shallow coastal areas in the vicinity of the nursery areas; eggs are demersal (Nissling *et al.* 2006)

References are indicated by the following superscript numbers: 1: Déniel (1981), 2: Felix *et al.* and references therein (2011), 3: Rae & Devlin (1972), 4: Delbare & De Clerck (1999), 5: Ongenae & De Clerck (1998), 6: Jones (1972), 7: Jones (1974), 8: Riley (1981), 9: Gibson (1997), 10: Person Le Ruyet *et al.* (1991), 11: Hachero-Cruzado *et al.* (2007), 12: Mcevoy (1984), 13: ICES (2012b).

Table 2 Sampling locations, regional code and country, number of individuals (N) of *S. cophtthalmus maximus* and *S. rhombus*

Geographical region	Sample location	Sample ID	Mean position			COI			Cytochrome b		
			Latitude	Longitude	N Turbot	N Brill	N Turbot	N Brill	N Turbot	N Brill	
Baltic Sea	Åland Sea	ALD	60.1	19.3	4					17	
	Estonian Coast	EST	59.2	23.2	4					16	
	Gotland Island	GOT	57.2	18.7	3					19	
Transition Area	Arkona Sea	ARK	54.8	13.8	4	5	5	10	5	5	
	Belt Sea	BEL	54.5	11.2				9	16		
	Kattegat	KAT	56.5	11.3	4	5	5	9	10		
North Atlantic	West Coast of Norway	NNS	62.0	4.0				25			
	Iceland	ICE	63.4	-16.3	5			12			
North Sea	German Bight	ENS	55.5	6.7	5	5	5	12	19		
	Central North Sea	CNS	54.1	2.1			2	18	2		
	Southern North Sea	SNS	51.7	2.2	5	5	5	12	9		
English Channel	Eastern English Channel	EEC	50.4	0.6	5	4	4	1			
	Western English Channel	WEC	50.0	-2.8	5	2	2	10	16		
British Isles	Bristol Channel	BCH	50.7	-5.5	5	4	4	10	8		
	South East Ireland	SEI	51.6	-6.0	5	5	5	13	11		
	Irish Sea	IRS	53.6	-5.0	4	4	4	18	23		

West Ireland	West Ireland	WIR	54.6	-9.0	5	4	19	16
West Scotland	West Scotland	WSC						12
Bay of Biscay	Bay of Biscay	BOB	45.2	-1.8	3	5	17	21
	Northwest Spain	NWS	43.7	-7.4			15	24
Portugal	Portuguese Coast	POR	42.6	-8.8			10	5
Adriatic Sea	Adriatic Sea	ADR			3	5	11	19
Aegean Sea	Gulf of Kavala	KAV			2	5		
Black Sea	Black Sea	BLS			5	3	18	3

## Phylogenetic and network analyses

Before conducting a phylogenetic analysis, alignment quality was checked by eye and in the software package trimAL (Capella-Gutiérrez *et al.* 2009). Substitution saturation was tested using DAMBE v 5.3.48 (Xia 2013). The index of substitution saturation (Iss) was significantly smaller than its critical value (Iss c) for both genes, which is an indication of little saturation. The final *cytb* data set comprised of 70 unique haplotypes out of the 219 individuals for brill (603 bp) and 52 haplotypes for turbot (483 bp) out of the 301 sequenced individuals. For COI the final length of the amplified products was 595 bp for brill and represented 5 unique haplotypes out of the 57. For turbot 18 unique haplotypes of 652 bp were observed out of 74 sequences.

Phylogenetic trees were constructed using Maximum Likelihood (ML) and Bayesian methods. JModeltest v 2.1.2 (Posada 2008) identified the HKY+I and TrN+G as the best fitting model of evolution for the COI and *cytb* datasets, respectively. For subsequent implementation in phylogenetic software, we chose the GTR+G substitution model for *cytb*, as best alternative for the TrN model. The uncorrected *P*-genetic distances were computed using MEGA v 5.1 (Tamura *et al.* 2011).

The ML trees were generated running the Randomized Accelerated Maximum Likelihood algorithm RAXML (Stamatakis 2006) via RAXMLGUI v 1.3 (Silvestro & Michalak 2012), assessing nodal support through 1000 bootstrap samples. The Bayesian-inference method was used to evaluate alternative tree topologies through the estimation of posterior probabilities using MRBAYES v 3.1 (Huelsenbeck & Ronquist 2001; Ronquist & Huelsenbeck 2003). The analysis ran four chains simultaneously, each for  $1 \times 10^6$  generations, sampling every 100<sup>th</sup> generation until an average standard deviation of split frequencies of nearly 0.01 was reached and a Potential Scale Reduction Factor (Gelman & Rubin 1992) converging towards 1. Sample points generated before reaching stationary values were discarded as “burn-in” samples. To assess the phylogenetic content of the datasets, a likelihood-mapping analysis (Strimmer & von Haeseler 1997) was performed in TREE-PUZZLE v 5.2 (Schmidt *et al.* 2002). Files containing alignments were converted using ALTER (Glez-Peña *et al.* 2010) and trees were drawn with FIGTREE v 1.3.1 (<http://tree.bio.ed.ac.uk/software/figtree/>) and MEGA v 5.1 (Tamura *et al.* 2011).

## Molecular clock calculations

A likelihood ratio test was performed in TREE-PUZZLE v 5.2, to test the molecular clock hypothesis. To date evolutionary splits between species, the times to the most recent common ancestor (tMRCA) of turbot and brill was estimated using Bayesian inferences as implemented in BEAST v 1.7.5. (Drummond & Rambaut 2007) according to the evolutionary model identified using jModeltest. The rate variation between sites was modeled using a gamma distribution in case of *cytb* with eight rate categories. Divergence times with credibility intervals were computed under the assumption of constant population size, with expansion growth and a lognormal relaxed clock. Dates of divergence between lineages were calculated using a conventional clock for the mitochondrial DNA. Substitution rates for Teleostei seem to vary between 1% per million years for protein coding mtDNA sequences (Ho *et al.* 2005) to 2% per million years (Arbogast & Slowinski 1998; Patarnello *et al.* 2007). We used 0.5 and 2.5% mutation rates for conservative considerations, which is equivalent to 0.0025 and 0.0125 mutations/site/my respectively. All estimated dates were approximated by sampling parameters at an interval of 500 generations over  $3 \times 10^7$  Markov chain Monte Carlo steps, after discarding  $3 \times 10^6$  burn-in steps. The output of BEAST was verified using TRACER v 1.5 (Drummond & Rambaut 2007).

## Network analysis and genetic differentiation

Intraspecific relationships among the mtDNA haplotypes were inferred using statistical parsimony with the software TCS v 1.13 (Clement *et al.* 2000). The genetic diversity, expressed in haplotype ( $h$ ) and nucleotide ( $\pi$ ) diversities, was analysed using DnaSP v 5.0 (Librado & Rozas 2009) and pairwise estimates of the population differentiation ( $F_{ST}$ ) were obtained with ARLEQUIN v 3.5 (Excoffier & Lischer 2010).  $F_{ST}$  matrices were visualized in a two-dimensional multidimensional scaling (MDS) plot using STATISTICA v 11 (STATSOFT).

## Demographic analyses

Demographic expansions were investigated from the *cytb* sequences by means of two neutrality tests: the Tajima's D test of neutrality (Tajima 1989) and Fu's  $F_s$  test (Fu 1997). Both the  $D$  and  $F_s$  tests are expected to produce negative values in case the clades underwent a sudden demographic expansion. Both tests were performed in DnaSP v 5.0 (Librado & Rozas 2009) and their significance was estimated via 1000 implemented coalescent simulations. Values were considered significant if the probability of occurrence in a neutral population of stable size was lower than 0.05.

To study the effect of regional founder events during the postglacial colonization history of turbot and brill, changes in effective population size ( $N_e$ ) were also studied by mismatch distribution analyses using ARLEQUIN v 3.5 (Excoffier & Lischer 2010). The mismatch distribution is usually unimodal in systems not in equilibrium, where populations have passed through a recent bottleneck (Slatkin & Hudson 1991; Rogers & Harpending 1992). Changes in regional effective breeding population size ( $N_e$ ) through time are investigated using a Bayesian skyline plot in BEAST v 1.7.5. (Drummond & Rambaut 2007). The theoretical expectation is that  $N_e$  changes over time in the presence of population expansion following for instance a founder or a bottleneck event (Drummond *et al.* 2005). Final analyses were run for  $3 \times 10^7$  generations, sampling every 1000<sup>th</sup> generation and a burn-in of  $3 \times 10^6$  generations. Analyses were repeated with 5, 10 and 20 grouped intervals under the strict molecular clock (see Supplementary Information).

### Scenario reconstructing using Approximate Bayesian Computation

Approximate Bayesian Computation(ABC), implemented in DIYABC v 1.0.4.46 (Cornuet *et al.* 2008) was used to investigate the dynamics of the colonization process. Since pairwise  $F_{ST}$  and network analysis revealed three distinct genetic groups within each species (see results: Atlantic, Adriatic and Black Sea), we ran DIYABC to compare different colonization scenarios. Six scenarios were simulated, involving three populations representing the three groups. Priors were as follows: effective population size for turbot and brill ( $N_1$ ,  $N_2$ ,  $N_3$  and  $N_4$ ) between 10 and 500,000, and timing of the events ( $t_0$ ,  $t_1$ ,  $t_2$  and  $t_3$ ) taken from the estimates from the mismatch analysis. The most ancestral split between the groups was fixed for all simulations at  $t_2$ , and the split between the two most recent groups at  $t_1$ . Scenarios were as follows: the first two populations have diverged from an ancestral population at  $t_2$ . At time  $t_1$  a third population could have diverged from one of these ancestral populations, one clade at a time (scenarios 1,2,3,6), or an admixture event between the two populations gave birth to an admixed populations (scenario 5), or lastly, two clades entered the new basin at the same time at  $t_3$  (scenario 4). As recommended in Cornuet *et al.* (2010), an unsampled lineage of different population size ( $N_4$ , yellow in Figure S3) was included in some scenarios. All other parameters were set as default, with the only constraint being that the timing of the third split in scenario 4 could not be older than the second event ( $t_3 < t_1$ ). One million simulated data sets per scenario were used to produce posterior distributions. Reliability of scenarios was visualized through Principal Component Analysis and posterior probabilities of scenarios were compared by means of both logistic regression and direct estimates convergence, using 1% of the closest simulated data sets (Coscia *et al.* 2013).



## RESULTS

### Phylogenetic analysis

The 70 *cytb* haplotypes of brill contained 60 (0.1%) polymorphic sites of which 24 (0.04%) were parsimony-informative, while in turbot a total of 47 (0.1%) polymorphic sites contained only two (0.004%) parsimony informative sites. The number of nucleotide differences within brill ranged from one to 61, corresponding with a maximum genetic *P*-distance of 1.4%. In turbot, inter-individual nucleotide differences ranged between zero and 47, corresponding to a maximum *P*-distance of 1.7%. Considering all Scophthalmidae, the genetic divergence was highest between *Scophthalmus maximus* and *Phrynorhombus norvegicus* (*P*-distance of 24.6%), whereas *Lepidorhombus bosci* and *L. whiffiagonis* displayed the smallest divergence (*P*-distance of 12.6%). The latter two species seem more closely related than turbot and brill based on genetic distance (*P*-distance of 19.6%).

A total of five polymorphic sites within the COI dataset were observed for brill, of which none were parsimony-informative. For turbot, on the other hand, a total of 16 (0.02%) polymorphic sites were found of which seven (0.01%) were parsimony informative. Considering the low divergence in this gene, the genetic differentiation between all species was 23.4%. Within Scophthalmidae, the number of nucleotide differences ranged from 9.3%, between *L. bosci* and *L. whiffiagonis*, to 21.5% between *S. maximus* and *P. norvegicus*. Likelihood mapping showed that 86.7% of the quartets were fully (“tree-like”) and 3.9% partially (“network-like”) resolved, whereas 9.4% remained unresolved for COI. For *cytb* these values amounted to 84.2%, 3.5% and 12.4%, respectively. From a biological standpoint, a likelihood mapping analysis showing more than 20-30% of the points in the star-like or network-like area suggests that the data are not reliable for phylogenetic inference (Lemey *et al.* 2009), which is clearly not the case here. Although the maximum likelihood and the majority rule consensus tree based on Bayesian inference gave identical topologies, the resolution and statistical support was much higher for the Bayesian analysis. In general, clades were statistically well supported (Figure 2). The separation between the Northeast Atlantic Ocean and the Black Sea clades of turbot were not significantly supported, pointing to a single species. Using the upper ( $2.5 \times 10^{-6}$  years) and lower ( $0.5 \times 10^{-6}$  years) assumed mutation rate, respectively, the tMRCA of turbot and brill was dated around 4.9-9.4 Mya (95% HDP *highest probability density* 1.7-22.4) and 24.7-46.5 Mya (95% HDP 24.7-46.5) for COI, whereas *cytb* estimates ranged between 11.2-20.4 Mya (95% HDP 13.9-27.7) and 56.3 and 102.5 Mya (95% HDP 69.9-138.5). As no geographically structured clades could be observed within each species, the time of diversification was only calculated between species.

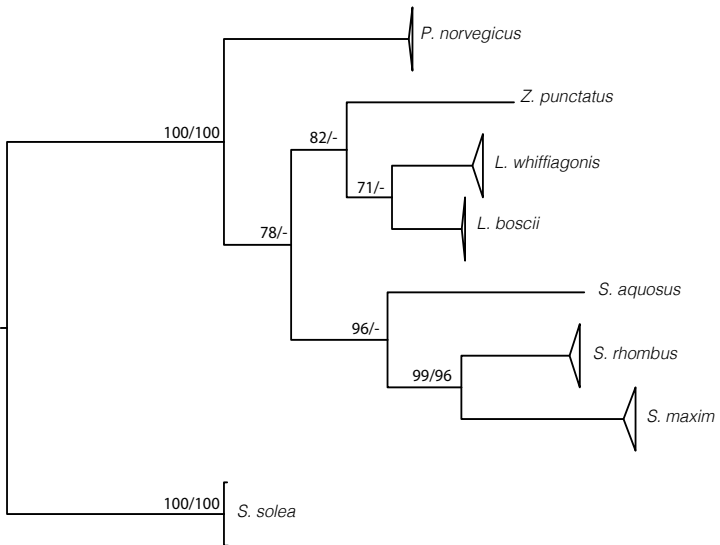
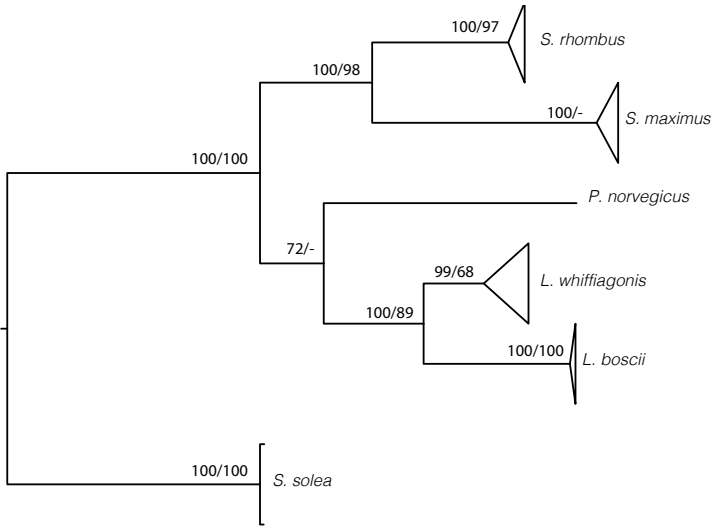

**Figure 2** Phylogenetic tree constructed for the *cytb* and *COI* sequences, respectively, of the *Scophthalmidae*. Statistical support for each node is shown as follows: BI posterior probability/ML bootstrap. Clades not recovered in a particular analysis are marked with '-'. Branch length indicates the expected number of substitution rates per site under Bayesian inference. Irrespective of the method or marker used, turbot appeared as a sister taxon of brill.

## Genetic diversity and network analysis

In turbot, an overall haplotype diversity ( $Hd$ ) and nucleotide diversity ( $\pi$ ) of  $0.816 (\pm 0.015)$  and  $0.0036 (\pm 0.00015)$  was found across 25 locations, respectively (Table 3). When calculated for each Atlantic location,  $Hd$  ranged between 0.619 and 0.864 (Table 3), with the highest value recorded off the Iberian Peninsula and the lowest in the Baltic Sea. Similarly, highest and lowest values of  $\pi$  were observed in the Iberian Peninsula and Baltic Sea (Table 3). Mediterranean turbot exhibit the lowest  $Hd$  and  $\pi$ :  $0.473 (\pm 0.162)$  and  $0.0011 (\pm 0.0004)$ , respectively (Table 3), whereas Black Sea turbot showed intermediate levels of diversity ( $Hd = 0.680 \pm 0.0055$  and  $\pi = 0.0018 \pm 0.0003$ ) (Table 3). Across the 18 sampled locations for brill,  $Hd$  averages to a value of  $0.782 (\pm 0.030)$  and  $\pi$  of  $0.0035 (\pm 0.0003)$  (Table 3). When calculated for each Atlantic location,  $Hd$  ranged from  $0.770 (\pm 0.066)$  to  $0.591 (\pm 0.106)$ , with the highest value recorded in the North Sea and the lowest in the Baltic Sea (Table 3). The highest values of  $\pi$  were observed off the Iberian Peninsula ( $0.0035 \pm 0.0006$ ), the lowest values in the Baltic Sea ( $0.0019 \pm 0.0005$ ). In contrast to turbot, genetic diversity was highest for Mediterranean brill with  $Hd$  and  $\pi$  values of  $0.906 (\pm 0.040)$  and  $0.0034 (\pm 0.0005)$ . For both species, there was no significant decrease in  $\pi$  northwards within the range, except for the Baltic area. Despite the higher diversity measures for turbot, populations were significantly more differentiated than brill throughout European waters based on pairwise  $F_{ST}$ -values (Table S2). Within both species two identical regional clusters are revealed, separating the Mediterranean and Black Sea (Figure 3).

The parsimony network revealed the presence of four main haplotypes in turbot (Figure 4). The most common haplotype (TYT-1) was present in 33% of the samples, whereas the second most common (TYT-6), was found in 24% of the samples. Both haplotypes were separated by two mutational steps, with a clear differentiation of Mediterranean and Black Sea individuals. TYT-6 occurred especially in the Mediterranean and Black Sea and together with TYT-9, they represent 72% and 83% of all individuals originating from the Adriatic and Black Sea respectively. For brill, the network analysis was much less resolved than turbot, as several smaller haplotypes were connected by only one mutation step from the central BYT-3 (Figure 5). Overall, however, there are a high number of haplotypes compared with the number of individuals of turbot and brill sequenced. The largest cluster of haplotypes reveals a star-shaped pattern with one central haplotype (BYT-3) found at high frequency (47%) in the Atlantic Ocean. Furthermore, four smaller haplogroups can be distinguished, two of them (BYT-24 and BYT-1) contain individuals from the Black and Mediterranean Sea. The other two highly frequent haplotypes occurred exclusively in the Atlantic Ocean (BYT-5 and BYT-2).

**Table 3 Diversity indices for the different geographical units in the Northeast Atlantic Ocean of turbot and brill. N: number of individuals per region, h: number of haplotypes, Hd: haplotype diversity,  $\pi$ : nucleotide diversity, SD: standard deviation**

Location	Code	Turbot						Brill					
		N	h	Hd	SD	$\pi$	SD	N	h	Hd	SD	$\pi$	SD
Atlantic Ocean	ATL	272	47	0.805	0.018	0.0035	0.0002	197	62	0.728	0.036	0.0030	0.0003
Baltic Sea	BAL	80	17	0.619	0.063	0.0029	0.0004	31	12	0.591	0.106	0.0019	0.0005
North Sea	NOS	90	16	0.815	0.023	0.0034	0.0003	46	21	0.770	0.066	0.0034	0.0006
Irish and Celtic Sea	IRS	60	15	0.802	0.034	0.0032	0.0003	70	31	0.764	0.056	0.0030	0.0004
Iberian Peninsula	IBE	42	14	0.864	0.031	0.0038	0.0005	50	19	0.727	0.069	0.0035	0.0006
Adriatic Sea	ADR	11	3	0.473	0.162	0.0011	0.0004	19	10	0.906	0.040	0.0034	0.0005
Black Sea	BLS	18	5	0.680	0.074	0.0018	0.0003	3	3	1.000	0.272	0.0033	0.0012
Overall		302	52	0.816	0.015	0.0036	0.0002	219	70	0.782	0.030	0.0035	0.0003

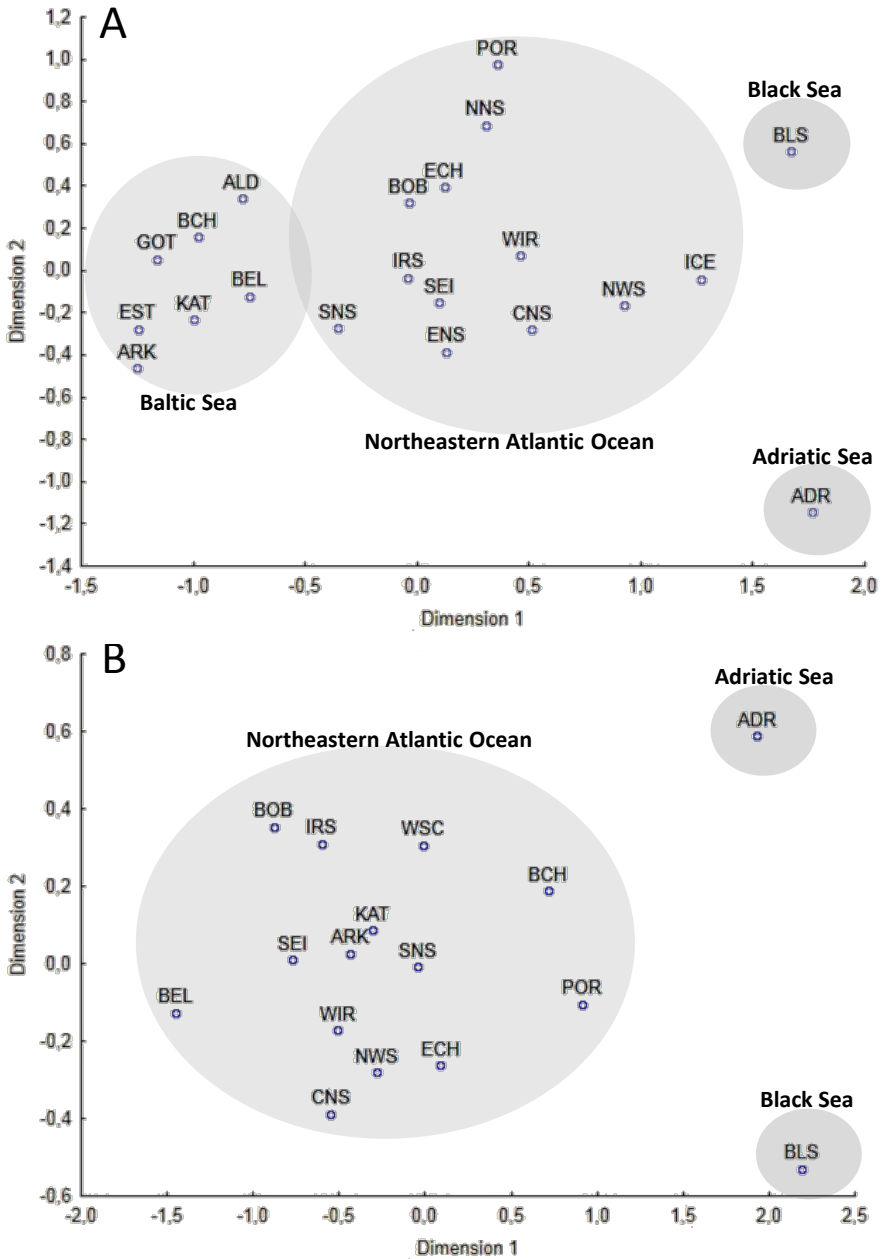

**Figure 3** Multidimensional scaling plots of the *cyt b* dataset based on pairwise  $F_{ST}$  of (A) turbot (stress value: 4.0) and (B) brill (stress value: 1.2). Grey circles delineate the significant genetic groups indicated by pairwise  $F_{ST}$ . Sample codes are available from Table 2.

## Demographic analysis

Despite the lack of clearly separated geographical clades in the phylogenetic tree for both turbot and brill, we chose to perform demographic analyses on separate populations based on pairwise  $F_{ST}$  values and the networks (Figure 3,4 and 5, Table S2). For brill this resulted in an Atlantic and Mediterranean group, whereas for turbot we performed additional separate analyses for the Baltic and Black Sea (we did not run the analysis for Black Sea brill because of the low sample size). We found significant, negative values of Tajima's  $D$  for turbot ( $D = -2.16$ ,  $p < 0.01$ ) and brill ( $D = -2.4$   $p < 0.01$ ) in the Atlantic samples (Table 4). Fu's  $F_s$  values were significantly negative for turbot in the Atlantic and Baltic samples ( $F_s = -36.25$  and  $-11.12$ , respectively), whereas for brill significant values were observed in both the Atlantic Ocean and Adriatic Sea ( $F_s = -83.80$  and  $-4.69$ , respectively, Table 4).

On average both turbot and brill display a shallow mismatch distribution, as pairwise nucleotide differences among haplotypes were small, ranging from 0.6 to 3 nucleotide differences for turbot and 2.1 differences were observed for brill in both the Atlantic and in the Adriatic Sea (Table 4).

## Scenario reconstructing using Approximate Bayesian Computation

The results from the DIYABC analysis supported scenario 6 as the most probable in brill (Figure 7). Illustrating that the Mediterranean and Black Sea populations differentiated from an unsampled ancestral populations 71.7 kya (97.5% HPD: CI 6,270-237,000). The oldest split took place 375 kya (97.5% HPD: 303,000-654,000) between that unsampled population and the Atlantic Ocean. For turbot the most likely scenario identified was 2 (Figure 6). Here, the Black differentiation first (187.2 kya, 97.5% HPD: 150,900-333,000), while the Mediterranean and Atlantic differentiated approximately 68.7 kya (97.5% HPD: 15,810-140,700). The effective population size ( $N_e$ ) of turbot in the Adriatic Sea is estimated at 43,600 (97.5% HPD: 6,360-174,000), while  $N_e$  for the Black Sea had intermediate values (137,000 97.5% HPD: 24,000-420,000) and 456,000 (97.5% HPD: 358,000-499,000) for the Atlantic). Estimates for brill showed substantial larger estimates, especially for the Mediterranean Sea (318,000 97.5% HPD: 66,500-493,000).

**Table 4 Results of the neutrality test and mismatch analysis for cytb sequences of turbot.  $\tau$ : time since expansion measured in mutational time units,  $P(\text{rag})$ :  $p$ -value for the raggedness index,  $P(\text{SDD})$ :  $p$ -value for the sum of the squared deviations under the hypothesis of sudden expansion. Significant tests of Tajima's  $D$  and  $F_u$ 's test are in bold ( $p$ -values  $< 0.05$ ).**

Location	Code	Demographic mismatch distribution						Spatial mismatch distribution					
		Tajima's $D$	$F_u$ 's $F_s$	$\tau$	$P(\text{rag})$	SDD	$P(\text{SDD})$	$\tau$	$P(\text{rag})$	SDD	$P(\text{SDD})$		
<i>Turbot</i>													
Atlantic Ocean	ATL	<b>-2.159</b>	<b>-36.250</b>	1.719	0.318	0.001	0.410	1.710	0.344	0.001	0.251		
Baltic Sea	BAL	-1.625	<b>-11.123</b>	3.000	0.521	0.024	0.364	2.247	0.731	0.008	0.748		
Adriatic Sea	ADR	-0.778	-0.659	0.600	0.588	0.015	0.330	0.641	0.590	0.015	0.227		
Black Sea	BLS	-0.774	-1.637	1.000	0.098	0.025	0.104	1.026	0.097	0.025	0.056		
<i>Brill</i>													
Atlantic Ocean	ATL	<b>-2.400</b>	<b>-96.479</b>	2.100	0.991	0.001	0.936	1.199	0.990	0.001	0.900		
Adriatic Sea	ADR	-1.244	<b>-4.690</b>	2.100	0.454	0.002	0.808	2.096	0.445	0.002	0.739		

TYT

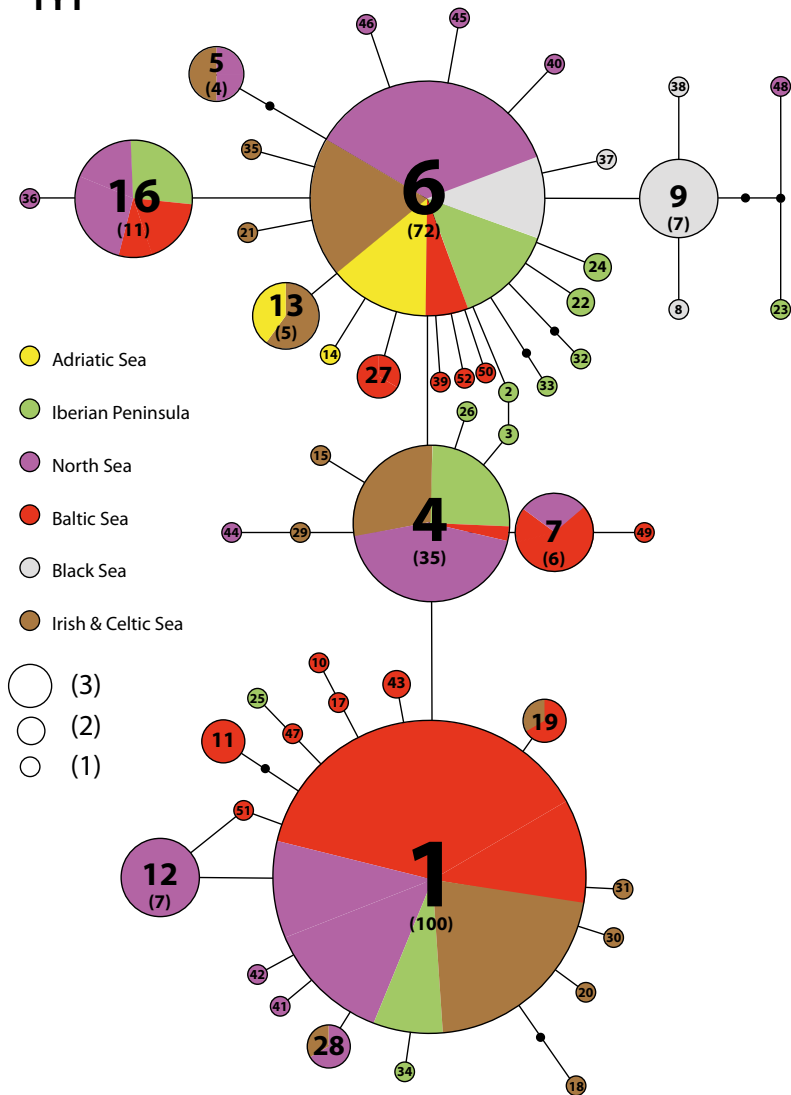

Figure 4 Statistical parsimony network of the *cytb* haplotypes of turbot in the Atlantic Ocean. The size of the circle is proportional to the number of turbot sharing that haplotype. The haplotypes are divided into eight large geographic areas: Black Sea and Adriatic Sea represent two isolated lineages, Iberian Peninsula includes samples from the Bay of Biscay, Northwest Spain and the Portuguese Coast, Irish and Celtic Seas consist of individuals caught in those areas and off the west coast of Ireland. The English Channel, and southern North Sea populations are grouped into the North Sea. German Bight, Iceland and Norwegian Coast represent the Northern European group, while samples from the Skagerrak, Kattegat and Belt Sea represent the transition zone between North Sea and all other Baltic Sea samples (Arkona Basin, Gotland, Estonia and Åland Sea). Large numbers in the circle code for a unique haplotype.



BYT

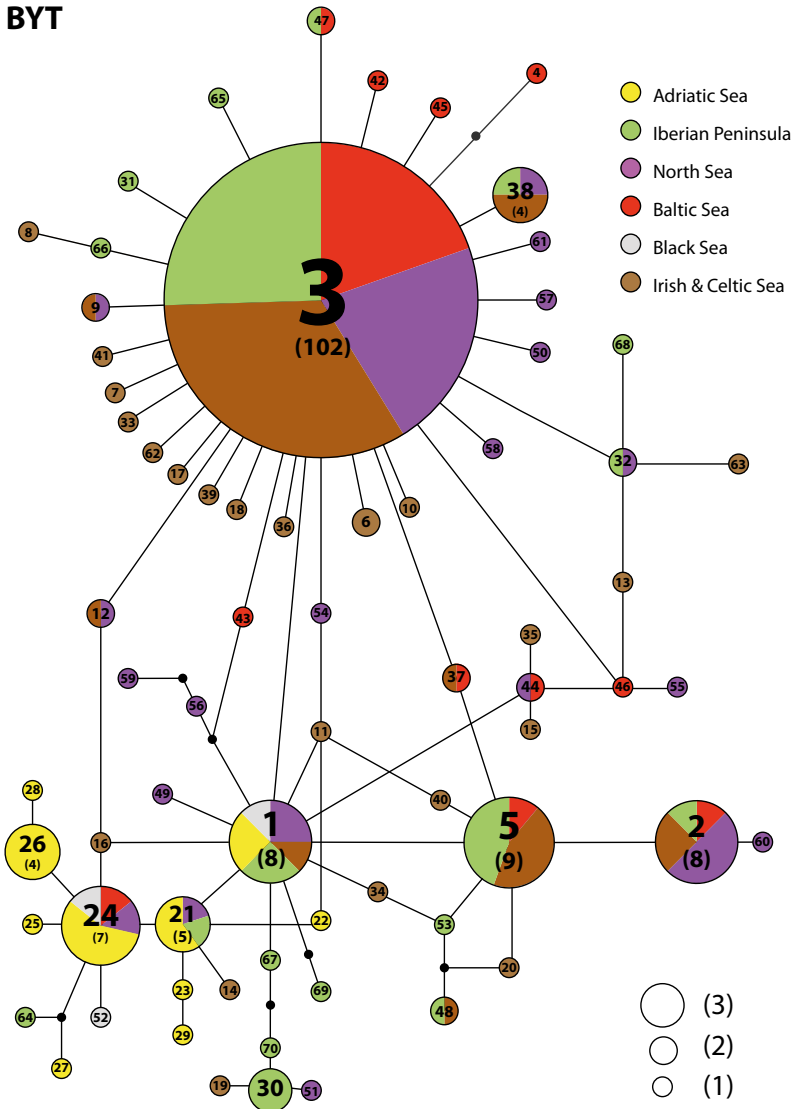

Figure 5 Statistical parsimony network of the *cytb* haplotypes of brill in the Atlantic Ocean. The size of the circle is proportional to the number of brill sharing that haplotype. The haplotypes are divided into eight large geographic areas: Black Sea and Adriatic representing two isolated lineages, Iberian Peninsula includes samples from the Bay of Biscay, Northwest Spain and the Portuguese Coast, Irish and Celtic Seas consist of individuals caught in those areas and off the west coast of Ireland and Scotland. The English Channel, and North Sea populations are grouped into the North Sea. German Bight represent the Northern European group, while samples from the Skagerrak, Kattegat and Belt Sea represent the transition zone between North Sea and samples from Arkona Basin represents Baltic Sea. Numbers in the circle represent an unique haplotype.

## DISCUSSION

In the present study we investigated whether the population structure of turbot and brill is the result of contemporary gene flow and ecological traits or of historical processes associated with climatic fluctuations. Despite their comparable distribution, the genetic structure of both species is different, implying a different demographic history. Results reveal that both turbot and brill populations have recently expanded resulting in relatively low levels of genetic differentiation at the within species level. Phylogenetic analysis confirmed that Black Sea and Atlantic lineages are conspecific and thus could be included in the phylogeographic analyses.

### Phylogenetic analysis

Our analyses confirmed the hypothesis of monophyly for both turbot and brill (Figure 2), confirming morphological studies (Chanet 2003; Bailey & Chanet 2010; Voronina 2010) and evolutionary phylogenies based on nuclear genes (Pardo *et al.* 2005; Azevedo *et al.* 2008; Betancur *et al.* 2013). Despite discrepancies between the analyses of both genes on the terminal branches, the position of turbot within the Scophthalmidae does neither change, nor does it affect the status of Black Sea turbot (*Scophthalmus maeoticus*). Therefore, our results offer support for the suggestion that *S. maximus* and *S. maeoticus* are conspecifics, with *S. maximus* being the senior available name for this species, affirming the morphological study by Baily and Chanet (2010). However, the phylogenetic trees did not identify distinct mitochondrial lineages in neither turbot, nor brill. The lack of such distinguishably geographically structured clades will be discussed further.

The tMRCA of *S. maximus* and *S. rhombus*, assuming an evolutionary rate of 2.5 and 0.5%, ranges between 4.8 and 46.5 Mya (95% HDP 1.7-46.5) based on the COI sequences. Based on the *cytb* sequences, the tMRCA of these two lineages ranged between 11.2-102.5 Mya (95% HDP 13.9-138.5), assuming an rate of 2.5 and 0.5% respectively. Very few fossils can be assigned to Scophthalmidae (Chanet 2003), which makes verification of these time estimates problematic. Fossil evidence suggests that scophthalmids first emerged and subsequently diversified by the Oligocene (ca. 35 Mya; Chanet 2003). One other record places the Scophthalmidae as a family already in the Eocene (35-56 Mya, Nolf 2013), which leads us to assume that the estimates for *cytb* are overrated. Campo & Garcia-Vazquez (2010) proposed that two other species within this family emerged around 5.3 Mya, associated with the Messinian salinity crisis (5.6 Mya).

Although we dated the split between turbot and brill around this same time-period, during the late Miocene-early Pliocene (3-9 Mya), an association with the Messinian salinity crisis is less likely given the broad haplotype distribution of both species across the Atlantic Ocean. The apparently very wide time estimates obtained with the *cytb* gene suggests that the evolutionary rates differ between both genes (Awise *et al.* 1998; Meynard *et al.* 2012). Calibration of the evolutionary rate of *cytb* is problematic (Johns & Awise 1998). Although studies have demonstrated that substitution rates in fishes are generally slower than in mammals (Cantatore *et al.* 1994), discrepancies between lineages have been reported (Cantatore *et al.* 1994; Johns & Awise 1998). Therefore, further phylogenetic analysis should be based on multi-locus sequence data to resolve interrelationships among species and confirmation of the estimated times (Betancur *et al.* 2013). Such multi-locus data sets should include nuclear sequences, as studies using only mitochondrial genes tend to find older node estimates than those based on nuclear genes, most likely related to differences in substitution rates between the two (Hurley *et al.* 2007; Meynard *et al.* 2012). Additionally, the use of complete mitogenomes may increase the resolution of establishing diversification events (Miya *et al.* 2003).

### Phylogeographic patterns and demographic history

Haplotype network analyses confirm a lack in regional- or population level genetic structure for both species, reflecting high levels of recent gene flow. This is further illustrated by the high haplotype diversity but low pairwise genetic divergence within each species (Table 3; Grant & Bowen 1998; Awise 2000). These results are consistent with a mismatch distribution suggesting historically a rapid expansion of the abundance and range of both species (Table 4 and Figure S2). Moreover, several Atlantic individuals are included in haplogroups containing mainly Mediterranean and Black Sea individuals (Figure 4 and 5), while no Mediterranean individuals are found in the large Atlantic haplotype group (TYT-1 and BYT 3 for turbot and brill, respectively, see Figure 4 and 5). Such mixes of long distance haplotypes may result from i) asymmetrical gene flow across phylogeographical barriers favouring e.g. immigration from the Atlantic into the Mediterranean, or ii) the time since separation of the populations has been insufficient to reach reciprocal monophyly, or iii) it is just the consequence of unequal sample sizes within each basin.

From a single-species perspective, the most distinctive observation for turbot is the genetic separation of the Black Sea group (Figure 3,4 and 5). Additionally, the relatively large number of haplotypes (Table 2) and the high level of differentiation suggest a Black Sea refugium for turbot throughout the last Glacial (Lambeck & Purcell 2005; Wilson & Veraguth 2010), as previously advocated by Suzuki *et al.* (2004).

Alternatively, turbot may have colonized the Black Sea basin only after its connection with the Mediterranean Sea (8 kya) and the relatively high genetic diversity in this region could reflect recent founder effects (Maggs *et al.* 2008; Wilson & Veraguth 2010). Nonetheless, ABC analysis shows that gene flow across the Dardanelles Strait has been low or nonexistent for the last 190 kya, as the Black Sea separated first from the Mediterranean and Atlantic populations (Figure 6). Such a temporal (pre-LGM) and spatial (Dardanelles Strait) phylogeographic boundary is in agreement with geological data (Mudie *et al.* 2002; Wilson & Veraguth 2010). Reconstructions of the Black Sea during the LGM illustrates that appropriate temperature and salinity conditions would have allowed turbot to survive (Mudie *et al.* 2002; Suzuki *et al.* 2004). Further sampling in the Sea of Marmara and the Aegean Sea will be necessary however, to provide additional support for the hypothesis of the region acting as a refuge during Pleistocene glaciations. Similar high genetic diversity in northern populations despite an absence of population substructure has also been observed in sprat and pipefish (*Sprattus sprattus*, Debes *et al.* 2008; *Syngnathus typhle*, Wilson & Veraguth 2010). Although the Mediterranean populations were diverse and strongly differentiated, their patterns for the Black Sea was in both studies very similar to that observed in turbot. One large difference between *S. typhle* and turbot is however that turbot shows much less admixed haplotypes in the Black Sea (Wilson & Veraguth 2010). The early separation of the Black Sea basin dating to long before the last glacial cycle (approximately 190 kya) may imply that the taxonomic dispute concerning Black Sea turbot is a result of this geographic isolation. The almost complete absence of present-day gene exchange, as suggested by microsatellite analysis (data not shown), might lead to the recognition of two distinct species (Avisé *et al.* 1998; Avisé 2000).

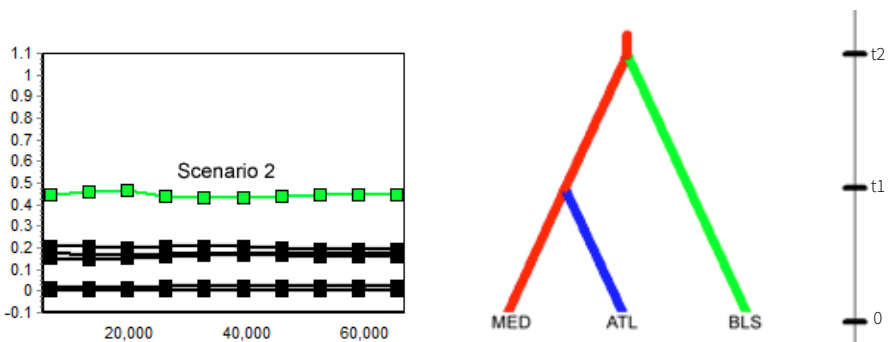

**Figure 6** Logistic regression plots for each simulated scenario of turbot. On the Y axis, the posterior probabilities, and on the X axis the number of simulations used to calculate it. The best-supported scenario is depicted on the right (ATL, Atlantic samples; MED, Mediterranean Sea samples; BLS, Black Sea samples).

The Mediterranean and Atlantic clades diverged more recently (Figure 6) during the last glacial cycle (60–80 kya). The limited differentiation between these two basins and the very low genetic diversity within the Mediterranean indicates that this species has been (re-) established only recently in the Mediterranean, without the possibility of accumulating detectable divergence since that time. Geological and paleoceanographical data illustrate that although glacial periods likely reduced gene flow between the Mediterranean and the Atlantic, during interglacial periods, the sea level was suddenly raised, providing opportunity to (re-) invade the Mediterranean basin (Hewitt 2000; Bargelloni *et al.* 2005).

Brill appears to have diversified earlier than turbot. Despite the larger *cytb* gene fragment, the network of brill is less resolved than for turbot. Pairwise divergence of Mediterranean haplotypes is larger than of Atlantic ones. Also, the estimated relative time of coalescence is higher for brill than for turbot (Table 4), indicating that the recolonization of this region might have involved a large group of individuals. Although the sampling strategy of the present study does not permit the precise determination of phylogenetic breaks in the Mediterranean region, a recolonization from the southern Adriatic was for example suggested for pipefish *Syngnathus typhle* (Wilson & Veraguth 2010) and reviewed by Paternello *et al.* (2007). However, the occurrence of some haplotypes originating from the Atlantic Ocean and even the Black Sea, complicates the interpretation. The appearance of Atlantic haplotypes as described for turbot, may easily result from asymmetrical gene flow across the Gibraltar Strait (Bargelloni *et al.* 2003; 2005; Charrier *et al.* 2006). The mixing of Black Sea and Mediterranean haplotypes might be the residual of a formerly diverse group (Bargelloni *et al.* 2005; Debes *et al.* 2008; Wilson & Veraguth 2010), as illustrated by the ABC analysis. Here, the Adriatic and Black Sea populations diverged from an unknown or extirpated population during the last glacial cycle (approximately 70 kya, Figure 7). Such heavily admixed assortment of haplotypes was also observed in *S. typhle* (Wilson & Veraguth 2010).

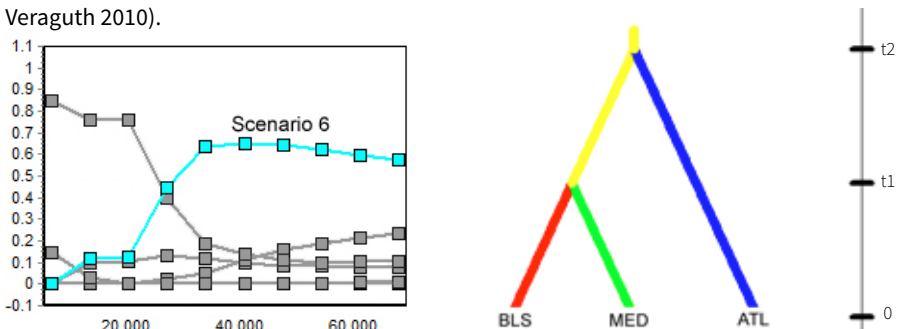

**Figure 7** Logistic regression plots for each simulated scenario of brill. On the Y axis, the posterior probabilities, and on the X axis the number of simulations used to calculate it. The best-supported scenario is depicted on the right (ATL, Atlantic samples; MED, Mediterranean Sea samples; BLS, Black Sea samples).

Although we acknowledge that including more samples from both the eastern and western basin of the Mediterranean Sea could increase the resolution of this study, the undersampling of this area is due to the scarcity of both turbot and brill in both Mediterranean basins. Cold adapted fish species may be declining as a result of climate change (Cheung *et al.* 2009; Azzurro *et al.* 2011). Therefore, rising temperatures in the Mediterranean may render it less suitable for the survival and reproduction of these two species (Almada *et al.* 2012).

For both species it seems difficult to speculate on the presence of refuges in Atlantic waters. The high haplotypes ( $h$ ) and low nucleotide divergence ( $\pi$ ) values across the entire region might be attributed to demographic expansion after a period of low effective size, with rapid population growth enhancing the retention of new mutations (Grant & Bowen 1998; Avise 2000; Maggs *et al.* 2008). This assumption is consistent with the star-like shape of the haplotype network observed in both turbot and brill (Figure 4 and 5). The recurrent pattern of a single or a few prevalent haplotype(s) with numerous rare haplotypes, one or two mutations removed from the common one(s) has been often observed in marine fishes (Grant & Bowen 1998; Maggs *et al.* 2008; Wilson & Veraguth 2010). Therefore, it might be concluded that both scophthalmids experienced a rapid demographic expansion in the Atlantic Ocean. Such a scenario could be explained by colonization and regression schemes of marine species that happened during the Pleistocene glaciation (Hewitt 2000; 2004). Similar shallow genealogies and homogeneity of genetic diversity across the entire range have been described in other species (Debes *et al.* 2008; Francisco *et al.* 2011; Almada *et al.* 2012). Nevertheless, these results must be interpreted with caution. First, although we sampled a significant part of the distribution range, some areas were not covered. Future sampling efforts should be focused on the Mediterranean basin and the Sea of Marmara. Second, glaciations induced sea level drops that may have caused changes in the inshore habitats. Such effects may be modeled in order to estimate the impact. Third, we limited our study to two mitochondrial markers. Nevertheless, our approach allows for a beneficial comparison between patterns found in other marine species, due to the wide use of these markers in other studies.

In conclusion, Plio-Pleistocene climatic oscillations differentially affected the contemporary genetic structure of brill and turbot. Whereas genetic differentiation between the Mediterranean, Black Sea and the Atlantic Ocean clades most likely resulted from such historical climate change events, our data suggest that within the Atlantic Ocean no further differentiation could be observed which most likely resulted from recent expansion and/or (re-) colonization.

Since this homogeneous pattern was also recovered using allozyme and microsatellite markers for brill (Bouza *et al.* 2002, Chapter 4) no species-specific traits or on-going selection pressures appear to be overwriting this historical effect. Contrastingly, recent studies on turbot demonstrated significant population subdivision characterizes the populations of the Atlantic Ocean (Vilas *et al.* 2010; Vandamme *et al.* 2013). Moreover, it is argued that in addition to natural selection (Vandamme *et al.* 2013) the specific spawning behavior and some not yet documented life-history characteristics in combination with contemporary ocean circulation and physical barriers enhance genetic differentiation (Chapter 4).

### **ACKNOWLEDGEMENTS**

The authors thank H. Theetaert for the assistance in the lab and W. Halfmaerten for figure editing. The authors also thanks M. Storr-Paulsen, F. Ivan Hansen, T. Saat, R. Eshbaum, B. Bland, A.-B. Florin, A. Nissling, A. Imsland, I. Holmes, J. Ellis, D. Stokes, R. Bunn, I. De Boois, M. Vera, C. Bouza, P. Calebout, G. Kyndt and B. Deputter for their help with collecting samples and ILVO for financial support. G.E.M. was a postdoctoral research fellow at the Fund for Scientific Research, Flanders (FWO) during the writing of this article and M.P.M.V. is supported by the Czech Science Foundation, Project no. P505/12/G112 (European Centre of Ichthyoparasitology (ECIP) – Centre of excellence).







# Chapter 3

## Seascape genetics of turbot

Foto: © Karl Van Ginderdeuren



# Chapter 3

## Regional environmental pressure influences population differentiation in turbot (*Scophthalmus maximus*)

Vandamme S.G., Maes G.E., Raeymaekers J.A.M., Cottenie K., Imsland A.K., Hellemans B., Lacroix G., Mac Aoidh E., Martinsohn J.T., Martínez P., Robbens J., Vilas R., Volckaert F.A.M.

### ABSTRACT

Unravelling the factors shaping the genetic structure of mobile marine species is challenging due to the high potential for gene flow. However, genetic inference can be greatly enhanced by increasing the genomic, geographic or environmental resolution of population genetic studies. Here we investigated the population structure of turbot (*Scophthalmus maximus*) by screening 17 random and gene-linked markers in 999 individuals at 290 geographical locations throughout the Northeast Atlantic Ocean. A seascape genetics approach with the inclusion of high resolution oceanographic data was used to quantify the association of genetic variation with spatial, temporal and environmental parameters. Neutral loci identified three subgroups: an Atlantic group, a Baltic Sea group and one on the Irish Shelf. The inclusion of loci putatively under selection suggested an additional break in the North Sea, subdividing southern from northern Atlantic individuals. Environmental and spatial seascape variables correlated marginally with neutral genetic variation, but explained significant proportions (respectively 8.7% and 10.3%) of adaptive genetic variation. Environmental variables associated with outlier allele frequencies included salinity, temperature, bottom shear stress, dissolved oxygen concentration and depth of the pycnocline. Furthermore, levels of explained adaptive genetic variation differed markedly among basins (3% vs 12% in the North and Baltic Sea, respectively). We suggest that stable environmental selection pressure contributes to relatively strong local adaptation in the Baltic Sea. Our seascape genetic approach using a large number of sampling locations and associated oceanographic data proved useful for the identification of population units as the basis of management decisions.

Published in Molecular Ecology (2013)

## INTRODUCTION

Population structure is determined by the interaction of homogenizing factors and geographic fragmentation. Knowledge on processes affecting the dispersal of marine organisms is crucial to understand their genetic distribution patterns and to manage effectively their populations (Nielsen *et al.* 2009b; Manel *et al.* 2010; Schunter *et al.* 2011). Most marine species have the capacity to disperse over vast geographical areas, either passively during the planktonic larval phase (White *et al.* 2010a; Selkoe & Toonen 2011) or actively through the migration of juveniles and adults (Gillanders *et al.* 2003; Pardoe & Marteinsdóttir 2009). For a long time the general lack of physical barriers in the sea has made man conclude that the occurrence of local adaptation should be restricted in high gene flow species (Palumbi 1994; Waples 1998; Galindo *et al.* 2010) due to the homogenizing effects that prevent locally adapted genotypes. In the last few years, however, many studies have illustrated that various mechanisms may explain how population structure evolves in a marine environment. Firstly, as a result of the historical separation of ocean basins and persistent oceanographical constraints, historical (phylogeographical) structure may persist (Vasemägi 2006; Bierne 2010; Bierne *et al.* 2011). Secondly, oceanographic features, such as eddies and fronts, may prevent random mixing and diffusion of pelagic larvae (Galarza *et al.* 2009a; Galindo *et al.* 2010; White *et al.* 2010a). Thirdly, environmental transitions such as salinity and temperature gradients, have been associated with genetic divergence, suggesting a level of local adaptation of populations to their native environment (Larmuseau *et al.* 2009; Limborg *et al.* 2012; Teacher *et al.* 2013). Finally, behavioural mechanisms acting at different life stages, e.g. natal homing, may reduce gene flow (Florin & Franzen 2010). Although marine fish are typically characterized by high levels of gene flow and low levels of differentiation at neutral loci (Waples 1998; DeWoody & Avise 2000; Cuveliers *et al.* 2012), strong signatures of local adaptation indicate that selection may override the homogenizing effect of gene flow (Bradbury *et al.* 2013; DeFaveri *et al.* 2013; Teacher *et al.* 2013). Concurrent variation in ecologically important traits (e.g., pelagic larval duration, migratory behaviour and spawning time) among populations may also indicate adaptive differentiation, possibly affecting resilience to environmental change and exploitation (Hauser & Carvalho 2008; Teacher *et al.* 2013). Evidence for temperature-associated adaptive population divergence has been suggested in Atlantic cod *Gadus morhua* (Bradbury *et al.* 2010; Star *et al.* 2011) and herring *Clupea harengus* (Teacher *et al.* 2013). Furthermore, cod (Larsen *et al.* 2012), herring (Limborg *et al.* 2012; Teacher *et al.* 2013) and flounder *Platichthys flesus* (Larsen *et al.* 2007) seem to be adapted to local salinity values.

At the same time, low levels of neutral genetic divergence were observed among these populations. Overall, the evidence for adaptation under high gene flow conditions remains scarce and hence may benefit from complementary case studies for a range of life-histories and ecologies.

The flatfish turbot (*Scophthalmus maximus*; Scophthalmidae) offers a fine opportunity to evaluate the effect of life-history strategy on the genetic divergence of populations, as different strategies characterize the species across its broad range on the European continental shelves, making local adaptation very plausible (Imsland *et al.* 2001a; Nissling *et al.* 2006; 2013; van der Hammen *et al.* 2013). For instance, unlike most other flatfish, turbot has the capacity to survive and reproduce at varying salinities, suggesting different locally adapted optima. Research has found that eggs from the North Sea develop optimally between 20 and 35 psu and do not survive at lower salinities, for example in the Baltic Sea (Karas & Klingsheim 1997). This contrasts with turbot eggs in the Baltic Sea, which develop demersally at salinities as low as 7 psu without any evidence for increased mortality (Nissling *et al.* 2006; 2013). Furthermore, tagging studies in the Kattegat and Skagerrak have revealed that adult turbot are sedentary (Aneer & Westin 1990; Stottrup *et al.* 2002), display a relatively strong spawning site fidelity and have restricted movement within a spawning season (Florin & Franzen 2010). This restricted migratory behaviour suggests that the actual movements of a single individual differ strongly from the potential dispersal, providing an opportunity for genetic differentiation based on geographical distance. In addition, the restricted dispersal of turbot might facilitate the evaluation of the effect of oceanographic features on its population structure. Previous studies on turbot illustrated that despite the generally weak spatial structuring indicated by neutral microsatellite loci over large geographical areas (Bouza *et al.* 2002; Nielsen *et al.* 2004; Florin & Hoglund 2007), turbot is predisposed to adaptive population divergence on a small spatial scale. For example, microsatellites isolated from expressed sequence tags (EST) suggest adaptive population divergence in the Baltic-Atlantic transition area (Vilas *et al.* 2010). Furthermore, inferences from a single candidate gene (haemoglobin) suggest population divergence between Iceland and west Norway on one hand and southwest Norway, Kattegat and Baltic Sea on the other hand (Imsland *et al.* 2003).

Here, a combination of genetic markers and multivariate techniques is applied to assess how environmental factors influence the genetic variation in turbot at various spatio-temporal scales. In contrast to previous studies on turbot, our sampling scheme covered nearly the entire distribution range of turbot, representing an open system experiencing multidirectional migration between many combinations of connected populations and across several environmental gradients. The marker panel allowed for the assessment of both the dynamics of gene flow and selection. We address the following questions: (i) what is the global population structure of the highly vagile turbot over a densely sampled geographical area, using random and gene linked markers, (ii) what is the proportion of the observed genetic variation attributable to demographic (neutral) or selective (adaptive) processes, enabling the pinpointing of footprints of selection, and (iii) to which degree neutral and adaptive population differentiation correlates with spatial, environmental or temporal variation? For this purpose, key environmental parameters were collected at every sampling site. Our results show that neutral loci mainly identify populations at a large scale (Baltic – Irish Sea), while loci putatively under selection identify an additional break within the North Sea. The adaptive genetic variation is significantly associated with seascape variables, suggesting that a stable environmental structure contributes to local adaptation in the Baltic Sea.

## MATERIALS AND METHODS

### Sampling

A total of 999 turbot samples were collected during research surveys or sampling onboard commercial vessels at 290 locations across the Northeast Atlantic Ocean between 2006 and 2010 (Table 1, Figure 1). Fin tissue samples were collected and preserved in 96% ethanol for genetic analyses. However, individuals collected in 2006 and 2007 were stored in a solution of TNES urea (see Estoup *et al.* 1998 for details). Temporal replicates were available for seven sampling locations within the Belt Sea, North Sea, Irish and Celtic Seas and Bay of Biscay (Table 1). For a comprehensive population genetic analysis, these newly collected samples were supplemented with additional samples from previous studies to cover almost the entire distributional and environmental range of turbot (see supplementary information and Table 1).

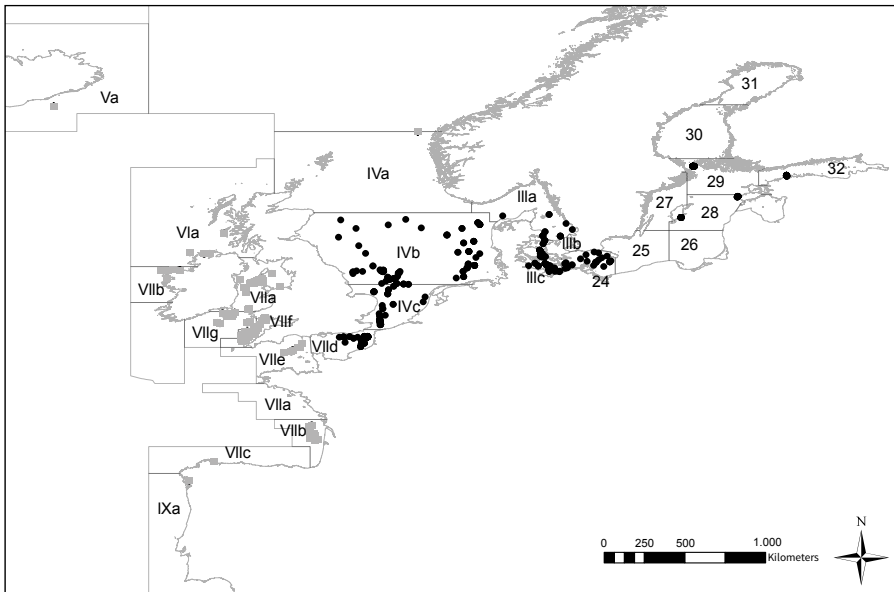

**Figure 1** Individual sampling locations of turbot. Samples used for the seascape genetic analyses are indicated with black circles; additional samples for the population genetic analyses are represented with light grey squares. Seas are labelled according to the ICES fishing rectangles.

**Table 1 Individual samples of turbot are clustered according to ICES fisheries rectangles. For each of these pooled locations information includes sampling ID, latitude, longitude, year of sampling, number of samples and whether samples were genotyped with neutral markers and/or putative adaptive microsatellites (N/A, respectively). Estimates of genetic diversity are based on neutral loci expressed in expected heterozygosity ( $H_e$ ) and allelic richness (AR). Also shown for each sample is the most likely of four clusters as inferred from STRUCTURE analysis based on the full marker set (see supplementary information). Samples used for the seascape genetic analyses are represented by a bold sample ID.**

Geographical Region	Sample location	ICES rectangle	Mean position			Year	Sample size	Genetic cluster	$H_e$	AR	Neutral or Adaptive
			Sample ID	Latitude	Longitude						
Baltic Sea	Åland Sea	29	ALD	60.1	19.3	2003	46	Baltic Sea	0.632	4.43	N & A
	Estonian Coast	32-28	EST	59.2	23.2	2010	48	Baltic Sea	0.649	4.41	N & A
	Gotland Island	28	GOT	57.2	18.7	2008	45	Baltic Sea	0.640	4.57	N & A
Transition Area	Arkona Sea	24	ARK	54.8	13.8	2010	24	Baltic Sea	0.598	4.03	N & A
	Belt Sea	Il1c	BEL10	54.5	11.2	2010	39	Baltic Sea	0.654	4.55	N & A
	Belt Sea	Il1c	BEL09	55.3	11.0	2009	26	Baltic Sea	0.667	5.00	N & A
	Kattegat	Il1a	KAT	56.5	11.3	2009	15	Baltic Sea	0.642	4.83	N & A
North Atlantic	West Coast of Norway	IVa	NNS	62.0	4.0	1997	45	Northern Atlantic	0.626	4.38	N & A
	Iceland	Va2	ICE	63.2	-21.1	1998-2010	43	Northern Atlantic	0.662	4.85	N & A
North Sea	German Bight	IVb	ENS	55.5	6.7	2010	53	Northern Atlantic	0.655	4.81	N & A
	Central North Sea	IVb	CNS10	54.1	2.1	2010	14	Northern Atlantic	0.655	4.66	N & A
	Central North Sea	IVb	CNS07	54.1	2.1	2007	48	Northern Atlantic	0.649	4.68	N
	Southern North Sea	IVc	SNS07	52.5	1.9	2007	18	Northeastern Atlantic	0.621	4.59	N
	Southern North Sea	IVc	SNS09	51.7	2.2	2009	32	Northeastern Atlantic	0.666	4.78	N & A



English Channel	Eastern English Channel	VIIId	EEC07	50.4	0.6	2007	29	Northeastern Atlantic	0.647	4.66	N & A
	Eastern English Channel	VIIId	EEC09	50.5	1.1	2009	51	Northeastern Atlantic	0.674	4.91	N & A
	Western English Channel	VIIe	WEC	50.0	-2.8	2010	16	Northeastern Atlantic	0.649	4.86	N & A
British Isles	Bristol Channel	VIIIf	BCH07	50.7	-5.5	2007	16	Northeastern Atlantic	0.644	4.50	N
	Bristol Channel	VIIIf	BCH09	51.4	-4.7	2009	20	Northeastern Atlantic	0.675	4.97	N & A
	Bristol Channel	VIIIf	BCH10	50.8	-5.5	2010	43	Northeastern Atlantic	0.662	4.75	N & A
	South East Ireland	VIIg	SEI	51.6	-6.0	2009	90	Irish Shelf	0.673	4.88	N & A
	Irish Sea	VIIa	IRS06	53.5	-53.0	2006	21	Irish Shelf	0.630	4.61	N
	Irish Sea	VIIa	IRS07	53.6	-5.0	2007	20	Irish Shelf	0.625	4.67	N
	Irish Sea	VIIa	IRS09	53.6	-5.0	2009	82	Irish Shelf	0.678	4.87	N & A
	West Ireland	VIIb-VIIa	WIR	54.6	-9.0	2009	26	Irish Shelf	0.672	4.81	N & A
Bay of Biscay	Bay of Biscay	VIIIb	BOB07	45.2	-1.8	2007	25	Northeastern Atlantic	0.652	4.83	N
	Bay of Biscay	VIIIb	BOB09	45.2	-1.8	2009	18	Northeastern Atlantic	0.680	4.81	N & A
	North and North West Spain	VIIc	NWS	43.7	-7.4	2000	27	Northeastern Atlantic	0.668	4.82	N & A
Portugal	Portuguese Coast	IXa	POR	42.6	-8.8	2000	19	Northeastern Atlantic	0.668	4.87	N & A

## Molecular analyses and microsatellite genotyping

Total genomic DNA was extracted using the Nucleospin Tissue Extraction Kit according to the manufacturer's guidelines (Macherey-Nagel GmbH, Düren, Germany). Samples were genotyped at 21 microsatellite loci on the automated capillary sequencer ABI 3130 AVANT (Applied Biosystems). Out of these 21 loci sourced from genomic libraries, seven were previously characterized in Coughlan *et al.* (1996), Estoup *et al.* (1998) and Iyengar *et al.* (2000) (*Sma3-8INRA*, *Sma3-12INRA*, *Sma3-129INRA*, *Sma4-14INRA*, *Sma5-111INRA*, *Sma1-152INRA*, *Sma1-125INRA*). The remaining 14 markers are Expressed Sequence Tag (EST) (E code) derived microsatellites described in Bouza *et al.* (2008) (*SmaUSC-E1*, *SmaUSC-E2*, *SmaUSC-E4*, *SmaUSC-E5*, *SmaUSC-E7*, *SmaUSC-E8*, *SmaUSC-E10*, *SmaUSC-E21*, *SmaUSC-E26*, *SmaUSC-E28*, *SmaUSC-E32*, *SmaUSC-E36*, *SmaUSC-E40*, *SmaUSC-E41*). These EST loci were chosen based on their fragment length and type of repeat motif, so that they could be combined in the multiplex PCR reactions. Microsatellite markers were combined into three multiplex reactions; two of the PCR reactions used a touchdown protocol. Details on the PCR conditions of microsatellite markers are presented in the supplementary information (Table S1). The allele sizes were determined using an internal lane size standard (250 LIZ) and the GENEMAPPER v.4.0 software package (Applied Biosystems). Furthermore, the TANDEM v.1.07 software package was used for automated allele binning (Matschiner & Salzburger 2009). Approximately 15% of all samples were re-genotyped to check for reproducibility.

## Quality of genotyping and summary statistics

Individuals were classified into 29 spatio-temporal samples according to ICES fisheries subdivisions (Table 1, Figure 1). For every sample, MICRO-CHECKER v.2.2.3 (van Oosterhout *et al.* 2004) was used to check for potential technical problems such as null alleles, stuttering and large allele dropout. FSTAT v.2.9.3 software (Goudet 1995) was used to estimate the amount of genetic variation within samples as allelic richness (according to El Mousadik & Petit 1996), the number of alleles and observed and expected heterozygosity. Deviation from Hardy-Weinberg equilibrium was tested per locus and sample using the exact test (Guo & Thompson 1992) implemented in GENEPOP v.4.1 (Raymond & Rousset 1995). Statistical significance was tested with 1000 permutations and adjusted using sequential Bonferroni correction to correct for multiple testing (Rice 1989).

## Outlier analyses

The 29 spatio-temporal samples were reduced to 20 spatial samples genotyped for all loci by pooling the temporal replicates (see Table 1). Two tests were applied to identify loci that showed divergent patterns of differentiation compared to neutral expectations and therefore potentially affected by selection. Firstly, we tested our dataset for outliers using the  $F_{ST}$  outlier method described by Beaumont & Nichols (1996), implemented in the LOSITAN software (Antao *et al.* 2008). We used  $10^5$  iterations and assumed 50 demes (varying the input parameters did not change the results). Runs were performed using the two possible mutation models: the stepwise mutation model and the infinite allele model. To minimize the risk of detecting false positives, we compared our results to outputs from a different, commonly applied method, the Bayesian approach of Beaumont and Balding (2004) as implemented in the BAYESCAN v.2.1 program (Foll & Gaggiotti 2008). We used the default MCMC parameters, varied the prior odds between 3 and 10 in favour of a model without selection. Correcting for multiple testing, the program computes  $q$ -values based on the posterior probability for each locus, and we considered loci with  $q < 0.1$  as significant outliers. Both outlier tests were conducted on all samples. The tests were repeated on a number of subsets including samples from the Baltic and North Sea, the Irish shelf and samples from the Iberian coast. Please check the supplementary information for the pairwise comparisons between geographic locations.

## Geographic structure of neutral and adaptive genetic variation

Two methods were applied to assess the current distribution of genetic variation in turbot. Genetic differentiation between the 29 spatio-temporal samples was estimated by global and pairwise  $F_{ST}$  (using Weir & Cockerham 1984 statistics) using FSTAT v.2.9.3. The Bayesian model-based clustering STRUCTURE v.2.3.3. program (Pritchard *et al.* 2000) was used to infer the number of genetically homogeneous groups. Considering the high levels of gene flow in turbot, we used the admixture model with the spatio-temporal origin as prior information, allowing for better performance for data with weak structure (Hubisz *et al.* 2009). For each simulation of  $K$  (1-10) 10 independent replicates were run. In total,  $10^4$  runs were used as burn-in, followed by  $10^5$  Markov Chain Monte Carlo (MCMC) iterations. The most likely number of clusters was selected by choosing  $K$  with the largest log-likelihood according to Evanno *et al.* (2005) implemented in the STRUCTURE HARVESTER v.0.6.92 web application (Figure S1, Earl & vonHoldt 2012). Assignment proportions to specific clusters per population were plotted following Mac Aoidh *et al.* (2013). More information can also be found in the supplementary information.

## Spatial, environmental and temporal correlation analyses

### *Environmental variables*

Detailed environmental data were available for the Baltic and North Sea representing 170 unique sites; turbot samples collected specifically in these basins were retained for the following analysis (Table 1). For each individual ( $N = 488$ ) we calculated average values of six habitat and three hydrodynamic variables collected between 1980 and 2004. These values were selected because (i) they are associated with known strong environmental gradients between the Baltic and North Sea (Poulsen *et al.* 2011; Limborg *et al.* 2012; Teacher *et al.* 2013) or because (ii) these variables influence demographic behaviour of marine species (e.g. Galarza *et al.* 2009a; Galindo *et al.* 2010). All data were extracted from the 10 km-resolution ECOSMO model (Schrum *et al.* 2003) and downloaded from the WGOOFE ICES working group website ([groupsites.ices.dk/sites/wgoofe](http://groupsites.ices.dk/sites/wgoofe)). Habitat variables included temperature of the sea surface and sea bottom (SST and SBT, respectively), salinity of the surface and bottom waters (SSS and SBS, respectively), oxygen concentration ( $O_2$ ,  $ml.l^{-1}$ ) and primary production (PP, expressed as  $g\ C.m^{-2}.d^{-1}$ ). The three hydrodynamic variables included bottom shear stress (BSS,  $m^2\ s^{-2}$ ), depth of pycnocline (PYC, m) and a density based stratification index (STRAT,  $kg.m^{-3}$ ) (for details see supplementary information). Annual estimates of environmental data may differ substantially from population-specific seasons potentially affecting divergent selection, thus we calculated different aggregated values for some variables. Due to the variation in seasonal water temperature, a climatological mean value was included for the summer season (July-September). As temperature has a large effect on other associated hydrodynamic variables, a summer average was calculated for oxygen concentration, depth of pycnocline and stratification. Mean net primary productivity was estimated for spring and summer (April-September), a period that includes the main spawning time for turbot and the occurrence of juvenile life stages (Jones 1972; Nissling *et al.* 2006; ICES 2012c).

These data were linked with the individual sampling sites by overlaying a global map of sampling sites and abiotic variables in ArcGIS v.10. First a vector grid was constructed using the ET Geo Wizard v.10.2 tool for ArcGIS. This polygon vector grid covers the entire area of the model data with a cell size as fine grained as the model, which reaches approximately  $10 \times 10\ km^2$ . After the establishment of this extra layer, the nearest environmental value was linked to the coordinates of each individual sampling location. In cases where model data were missing for a particular site (for example in the case of inshore samples), the value of the closest cell was extracted without extrapolation.

### ***Seascape analysis of neutral and adaptive variation***

Genetic differentiation affected by spatial, temporal or environmental variability or a combination thereof was estimated by partitioning the genetic variation into a spatial (S), temporal (T) and environmental (E) component. This allows for the investigation of independent and collinear effects. For instance, the proportion of genetic variation attributable to spatial autocorrelation of environmental data can be quantified, each explaining the genetic variation indicative for selection (rather than demography). Individuals with missing genotypes were removed from the dataset for this analysis (max. number of individuals is 466). The multilocus genetic data were coded as relative allele frequencies (individuals in rows, alleles in columns) using the ADEGENET package in R (Jombart *et al.* 2010). For each individual, frequencies are assigned a value 1 for a homozygote and 0.5 for a diploid heterozygote. No scaling was applied on these allele frequencies as this can drastically change the results (Jombart *et al.* 2009). The first group of explanatory variables was the nine environmental variables calculated using the ECOSMO model (see above). Secondly, a matrix of the sampling years was constructed using presence/absence to test for temporal stability. Lastly, geography was modeled with distance-based Moran's eigenvector maps (MEM) along with latitude and longitude, which might reflect historical trends in recolonization or range expansion (Gaggiotti *et al.* 2009; Gavilanez & Stevens 2012). For our analysis, we used the same method to generate axes as for the principal coordinate analysis of neighbour matrices (PCNM) (Borcard & Legendre 2002). A distance matrix between individuals was truncated above a threshold equal to the minimum distance required to form a network joining all sample points together (i.e., a minimum spanning tree). Distances above the threshold were re-assigned to four times the threshold. This threshold offers a reasonable balance between resolving fine and coarse-scale spatial structure (Borcard & Legendre 2002). However, only positive eigenvectors were retained for further analysis based on Moran's I. Depending on the geographic area under investigation, we constructed a different matrix with separate MEM variables (see below). Together with these MEM, latitude and longitude represents the explanatory matrix space.

We tested the null hypothesis, that each set of explanatory variables (S, T or E) does not explain genetic variation, separately for neutral and outlier loci. First, we performed a global analysis that involved all the individuals from the Baltic and North Sea. Furthermore, we also conducted variance partitioning on regional subsets to assess patterns at smaller scales: (i) North Sea samples and the transition zone, (ii) Baltic Sea and transition zone samples (see Table 1).

Variance components were estimated and tested for significance using  $10^3$  random permutations of the data. After calculating and testing the genetic variation explained by environmental, spatial and temporal data, we applied a canonical redundancy analysis (RDA). As with typical partial regressions, partial RDA can be conducted on residuals from another set of explanatory variables allowing us to control for variables such as spatial structure (Borcard *et al.* 2011). RDA and associated analyses were performed in R v.2.13 with the `VEGAN` package (Oksanen 2011). In the cases where the abovementioned RDA analysis were significant, we subsequently applied forward selection, as this corrects for highly inflated type I errors and overestimated amounts of explained variation. Forward selection adds suitable variables one at a time until the adjusted  $R^2$  is reached. Additional variables do not significantly improve the model (Sharma *et al.* 2012). This reduced panel of explanatory variables was used to recalculate the total proportion of genetic variation in the variance partitioning. The function used to perform the forward selection was implemented in the `PACKFOR` package in R (Dray *et al.* 2007).

## RESULTS

### Genotype quality and summary statistics

Genotyping problems were observed at locus *SmaUSC-E5* and MICRO-CHECKER analysis indicated that two loci (*Sma4-14INRA* and *SmaUSC-E1*) might be affected by null-alleles or stuttering. Stuttering was identified by estimating the average null-allele frequency using FREENA; as such these loci were omitted from the analysis. Locus *SmaUSC-E2* was almost completely fixed (number of alleles = 2) and due to its low informative status, it was not included in any statistical analysis. Observed Hardy-Weinberg disequilibria could not be specifically associated with one locus or population specifically, and hence all 17 remaining loci were retained for further analysis. Details on genetic diversity indices is provided in the supplementary information and Table 1.

### Outlier analyses

Applying the FDIST method, we detected three loci, *Sma1-152INRA*, *SmaUSC-E4* and *SmaUSC-E7*, potentially influenced by directional selection in a global analysis. All three loci exceeded the 99% confidence limit of neutral expectations, even when corrected for multiple testing (FDR lower than 10%). BAYESCAN analysis was consistent with the identification of both *SmaUSC-E4* and *SmaUSC-E7* as potential outliers according to the prior odds favouring the neutral model of 3 and 10, respectively and using a  $q < 0.1$ . Loci subjected to putative balancing selection were not retained, as its detection and interpretation is difficult and much less robust (Foll & Gaggiotti 2008; Teacher *et al.* 2013). This is especially relevant in the case of this species that might experience high gene flow and a low microsatellite diversity.

### Geographic structure of neutral and adaptive genetic variation

Bayesian clustering tests and pairwise  $F_{ST}$  estimates based on neutral loci indicated that turbot is subdivided into genetically distinct subpopulations (Figure 2). Baltic and Atlantic individuals were clearly separated. A subgroup was suggested with individuals caught on the Irish shelf (Figure 2). Outlier loci revealed a subtle break within the North Sea, where southern North Sea individuals were more affiliated with the Irish samples (Figure S2). More detailed results on the population genetic analysis can be found in the supplementary information.

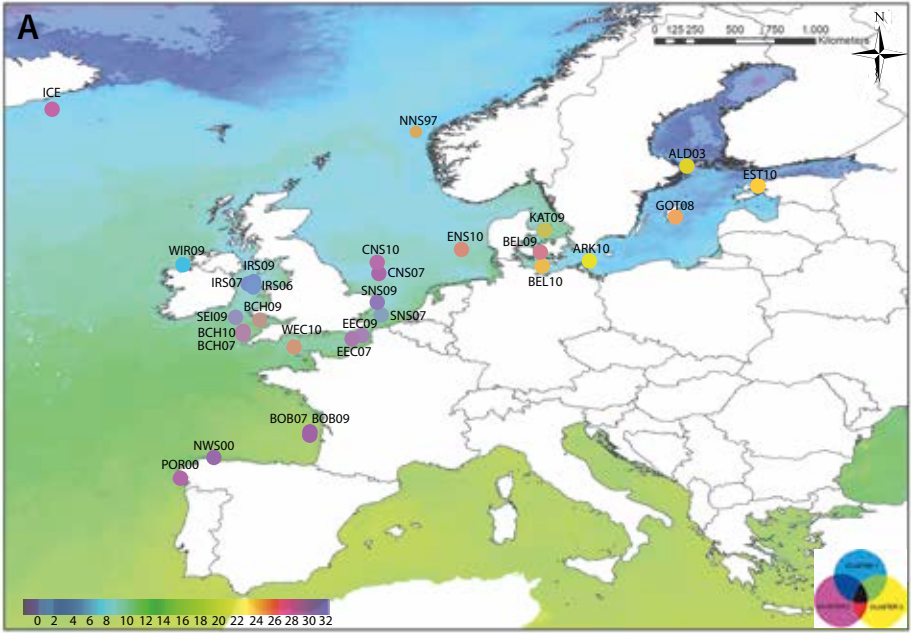

**B**

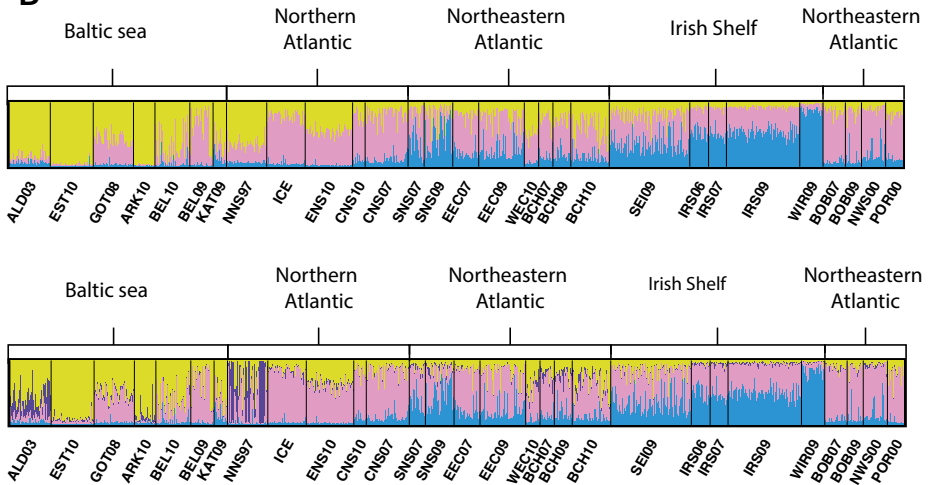



Figure 2 A) Map of sampling locations and estimated probability of cluster membership obtained from the STRUCTURE analysis based on neutral microsatellite data. Individuals belonging to the Baltic cluster (see Table 1) are mainly represented in yellow. Irish samples (WIR, Table 1) have been appointed to cyan and northern Atlantic samples are addressed in magenta. All other locations are represented as a mix of these three base colours in accordance to the individual Q-values in STRUCTURE. Sea surface temperature for May 2011 is plotted as colour tones in the background. Additional environmental parameters can be consulted for turbot at the following website: [https://fishreg.jrc.ec.europa.eu/map/genetics\\_geobrowser](https://fishreg.jrc.ec.europa.eu/map/genetics_geobrowser). B) Individual assignment based on 14 neutral loci for K values of 3 and 4 from STRUCTURE. Each bar represents an individual with its probability of membership to one of the hypothetical clusters. Samples are ordered in accordance with geographical connectivity as illustrated by the top brackets; the geographical origin of each sample, irrespective of its genetic composition, is listed below the figure. Following figure A, colours representing the genetic clusters are: yellow = Baltic Sea, pink = North-eastern Atlantic and blue = British Isles. See Table 1 for more information on samples.

## Correlation with spatial, environmental and temporal data

Overall, the predictor matrices explained a limited portion of the neutral genetic variation (Table 2). The highest correlation was found in each regional subset when a combination of the explanatory variables was used. When analysed independently, space contributed most to the global analysis and within the North Sea. In the latter, even when space is corrected for environmental and temporal variation, the correlation remains significant; the influence of spatial variation is more than twice the impact of environment and time. This contrasts with the Baltic basin, where the contribution of the three matrices is similar in magnitude (Table 2). However, overall the proportion is larger in the Baltic Sea than in the North Sea. Significant attribution to the environment was highest in the Baltic subregion (Table 2).

**Table 2 Results of variation partitioning analysis, showing those co-variables significantly associated with neutral genetic variation of turbot. Analyses were conducted in three regional subsets, a global analysis (including both North and Baltic Sea) and the two basins separately, both including samples from the transition area (covering Arkona Basin, Belt Sea and Kattegat). The dependent variables represent the neutral genetic data of 14 loci. Adjusted variance components ( $R^2_{adj}$ ) with their  $p$ -values are shown, presenting the unique and shared fractions explained by environment (ENV), space (SPACE) and time (TIME) The co-variables reported are significant following forward selection: SSS = Sea Surface Salinity, SST = Sea Surface Temperature, BSS = Bottom Shear Stress, MEM = Moran Eigenvector Map, LAT= Latitude and LON= Longitude Significant  $p$ -values are in bold ( $p < 0.05$ ). N indicates the total number of individuals included in the analysis.**

Neutral	Global analyses		Baltic-Transition		North Sea-Transition	
	$R^2_{adj}$	$p$ -value	$R^2_{adj}$	$p$ -value	$R^2_{adj}$	$p$ -value
N	466		236		230	
Total variation	2039.1		1029.3		997.26	
ENV	0.010	<b>0.001</b>	0.008	<b>0.001</b>	0.003	<b>0.010</b>
SPACE	0.011	<b>0.001</b>	0.005	<b>0.001</b>	0.012	<b>0.001</b>
TIME	0.008	<b>0.001</b>	0.007	<b>0.001</b>	0.005	<b>0.001</b>
ENV + SPACE	0.013	<b>0.002</b>	0.008	<b>0.026</b>	0.013	<b>0.002</b>
ENV + TIME	0.012	<b>0.001</b>	0.009	<b>0.007</b>	0.006	<b>0.001</b>
SPACE + TIME	0.013	<b>0.001</b>	0.008	<b>0.001</b>	0.015	<b>0.001</b>
ENV+SPACE+TIME	0.015	<b>0.001</b>	0.010	<b>0.011</b>	0.016	<b>0.002</b>
ENV SPACE+TIME	0.002	0.139	0.001	0.762	0.001	0.325
SPACE ENV+TIME	0.003	0.101	0.000	0.447	0.010	<b>0.021</b>
TIME ENV+SPACE	0.003	<b>0.004</b>	0.001	0.196	0.003	<b>0.008</b>
ENV TIME	0.005	<b>0.001</b>	0.002	0.093	0.001	0.178
ENV SPACE	0.002	<b>0.023</b>	0.003	<b>0.020</b>	0.001	0.130
SPACE TIME	0.006	<b>0.001</b>	0.001	0.129	0.010	<b>0.002</b>
SPACE ENV	0.003	<b>0.015</b>	0.001	0.277	0.010	<b>0.001</b>
TIME ENV	0.002	<b>0.011</b>	0.002	0.131	0.002	<b>0.013</b>
TIME SPACE	0.002	<b>0.008</b>	0.003	<b>0.020</b>	0.003	<b>0.007</b>
Residuals	0.985		0.990		0.984	

	Variable	Global analysis		Baltic-Transition		North Sea-Transition	
		R <sup>2</sup> adj	p-value	R <sup>2</sup> adj	p-value	R <sup>2</sup> adj	p-value
Forward selection							
ENV	SSS	0.005	<b>0.001</b>	0.008	<b>0.020</b>		
	SST	0.009	<b>0.001</b>	0.005	<b>0.001</b>	0.003	<b>0.005</b>
	BSS	0.010	<b>0.035</b>				
SPACE	LAT	0.011	<b>0.031</b>				
	LONG	0.004	<b>0.001</b>				
	MEM1	0.008	<b>0.010</b>	0.005	<b>0.002</b>	0.008	<b>0.023</b>
	MEM2	0.007	<b>0.001</b>				
	MEM3					0.012	<b>0.040</b>
	MEM6	0.010	<b>0.008</b>				
	MEM8					0.005	<b>0.012</b>
	MEM11					0.010	<b>0.039</b>
	MEM27					0.003	<b>0.005</b>
TIME	2007	0.003	<b>0.001</b>				
	2009	0.006	<b>0.001</b>	0.007	<b>0.015</b>	0.005	<b>0.003</b>
	2010	0.008	<b>0.002</b>	0.004	<b>0.001</b>		

In contrast to the neutral genetic variation, variation partitioning analysis of the adaptive genetic variation revealed a significantly larger proportion of explained genetic variation with the three predictor matrices (Table 3). In the global analyses, space (10.3%) and environment (8.7%) explained most of the variance in almost identical proportions (Table 3). Overall, the proportion of explained variation reached the same magnitude for all three matrices, with time accounting for the lowest level of correlation. When the matrices were corrected for the collinear effects, space and time explained the highest levels of genetic variation, except for the North Sea (Table 3).

**Table 3** Results of variation partitioning analysis showing the co-variables significantly associated with putatively adaptive genetic variation of turbot. Analyses were conducted in three regional subsets, a global analysis (including both North and Baltic Sea) and the two basins separately, both including samples from the transition area (covering Arkona Basin, Belt Sea and Kattegat). The dependent variables represent the genetic data of the three outlier loci. Adjusted variance components ( $R^2_{adj}$ ) with their p-values are shown, presenting the unique and shared fractions explained by environment (ENV), space (SPACE) and time (TIME). The co-variables reported were significant following forward selection: SSS = Sea Surface Salinity, SST = Sea Surface Temperature, SBT = Sea Bottom Temperature, BSS = Bottom Shear Stress,  $O_2$  = oxygen concentration, PVC = depth of pycnocline, MEM = Moran Eigenvector Map, LAT= Latitude and LON= Longitude. Significant p-values are in bold ( $p < 0.05$ ). N indicates the total number of individuals included in the analysis.

Outliers	Global analysis		Baltic-Transition		North Sea-Transition	
	$R^2_{adj}$	p-value	$R^2_{adj}$	p-value	$R^2_{adj}$	p-value
N	390		236		154	
Total variation	419.7		238.6		164.8	
ENV	0.087	<b>0.001</b>	0.095	<b>0.001</b>	0.023	<b>0.001</b>
SPACE	0.103	<b>0.001</b>	0.103	<b>0.001</b>	0.017	<b>0.001</b>
TIME	0.043	<b>0.001</b>	0.078	<b>0.001</b>	0.021	<b>0.001</b>
ENV + SPACE	0.109	<b>0.001</b>	0.112	<b>0.001</b>	0.026	<b>0.171</b>
ENV + TIME	0.104	<b>0.001</b>	0.106	<b>0.001</b>	0.034	<b>0.010</b>
SPACE + TIME	0.112	<b>0.001</b>	0.114	<b>0.001</b>	0.023	<b>0.027</b>
ENV+SPACE+TIME	0.111	<b>0.001</b>	0.116	<b>0.001</b>	0.033	<b>0.147</b>
ENV SPACE+TIME	-0.001	0.613	0.002	0.930	0.010	0.794
SPACE ENV+TIME	0.006	0.287	0.010	0.677	0.000	0.803
TIME ENV+SPACE	0.002	0.337	0.004	0.263	0.008	0.302
ENV TIME	0.062	<b>0.001</b>	0.028	<b>0.001</b>	0.013	<b>0.021</b>
ENV SPACE	0.006	<b>0.048</b>	0.009	<b>0.026</b>	0.009	0.059
SPACE TIME	0.069	<b>0.001</b>	0.036	<b>0.001</b>	0.002	0.187
SPACE ENV	0.022	<b>0.001</b>	0.018	<b>0.001</b>	0.002	0.215
TIME ENV	0.018	<b>0.001</b>	0.011	<b>0.005</b>	0.010	<b>0.012</b>
TIME SPACE	0.009	<b>0.003</b>	0.011	<b>0.005</b>	0.006	0.067
Residuals	0.889		0.884		0.967	

	Variable	Global analysis		Baltic-Transition		North Sea-Transition	
		R <sup>2</sup> adj	p-value	R <sup>2</sup> adj	p-value	R <sup>2</sup> adj	p-value
Forward selection							
ENV	SSS	0.036	<b>0.001</b>	0.083	<b>0.001</b>	0.023	<b>0.027</b>
	SST	0.072	<b>0.001</b>	0.048	<b>0.001</b>		
	BSS	0.076	<b>0.007</b>	0.095	<b>0.002</b>	0.015	<b>0.004</b>
	O <sub>2</sub>	0.079	<b>0.045</b>				
	PYC	0.083	<b>0.011</b>				
	SBT	0.087	<b>0.021</b>				
SPACE	LAT	0.056	<b>0.001</b>	0.042	<b>0.001</b>		
	LONG	0.077	<b>0.001</b>	0.097	<b>0.001</b>		
	MEM1					0.017	<b>0.006</b>
	MEM2	0.038	<b>0.001</b>	0.072	<b>0.001</b>		
	MEM3	0.100	<b>0.001</b>	0.103	<b>0.024</b>		
	MEM4	0.088	<b>0.001</b>				
	MEM10	0.103	<b>0.027</b>				
TIME	2007	0.043	<b>0.001</b>				
	2009	0.033	<b>0.001</b>	0.078	<b>0.001</b>		
	2010	0.020	<b>0.001</b>	0.057	<b>0.001</b>	0.021	<b>0.001</b>

Environment represents the largest proportion in the North Sea, whereas in the Baltic Sea the highest contribution was observed with spatial variation. One spatio-temporal replicated sample was included in the analysis within each basin (Table 1). For each region, the effect of the year in which the sampling occurred explained a significant but smaller proportion of the variation than the effect of spatial and environmental variables. The value of temporal correlation was three times higher in the Baltic Sea basin (7.8%) than in the North Sea basin (2.1%). Furthermore, variation partitioning analyses demonstrated that unique and shared contributions of predictor matrices differed, particularly when looking at the significance and magnitude of fractions for the two subregions independently (Table 2 and 3).

### Proportional importance of environmental vs. spatial factors

In the global analysis, both neutral and adaptive genetic variation were significantly associated with salinity, temperature and bottom shear stress (Figure 3). However, the proportion of correlation was much higher for the adaptive genetic variation than for the neutral variation (Tables 3 and 2 respectively). Within the Baltic Sea, neutral variation was associated with temperature and salinity, whereas in the North Sea only temperature contributed significantly. Adaptive genetic variation in the Baltic Sea was more strongly correlated with temperature, salinity and bottom shear stress. In the North Sea the latter two variables play a role.

Independent RDA analyses were conducted across the full region for each outlier locus (Table S4) to identify different variables associated with locus-specific alleles. Independent of the geographic area, *SmaI-152INRA* was associated with both temperature and bottom shear stress. We observed association with both temperature and salinity at locus *SmaUSC-E4*, except in the North Sea. Here, no environmental variable was significantly correlated with the allelic variation of locus *SmaUSC-E4*. Locus *SmaUSC-E7* correlated with salinity in the Baltic region and with depth of the pycnocline. All loci were significantly associated with spatial variables, potentially indicating isolation-by-distance reinforced by environmental factors.

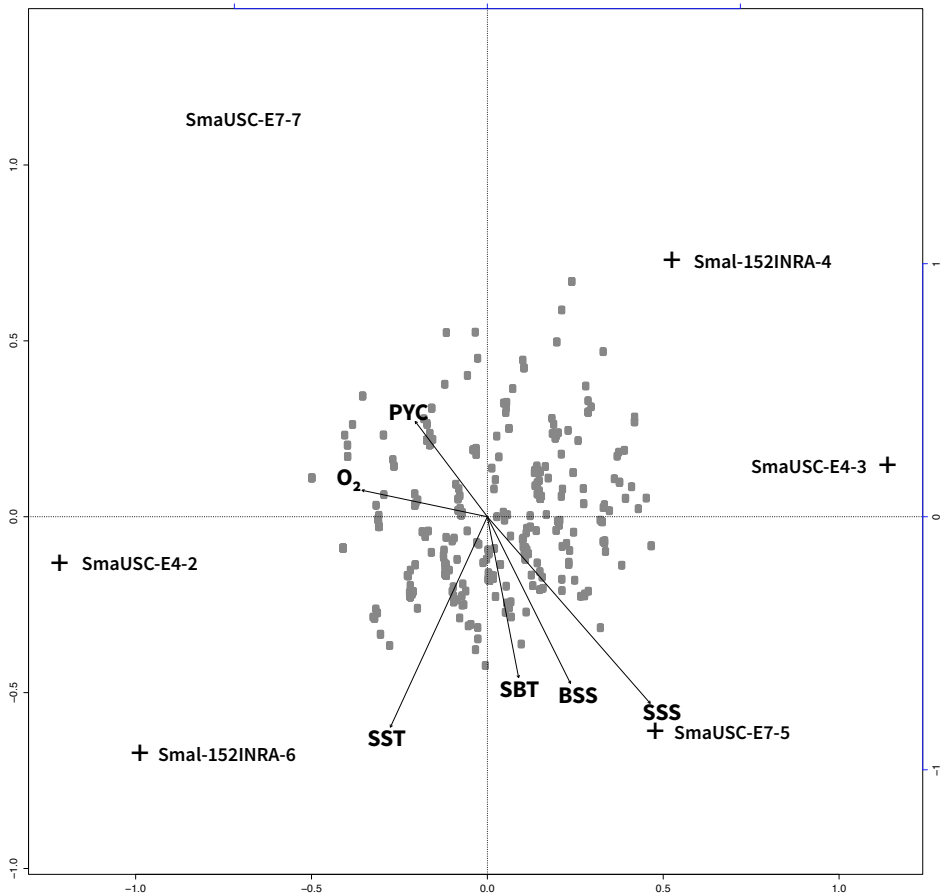

**Figure 3** Canonical redundancy analysis based on the outlier genotypes of turbot in the Baltic Sea and North Sea. The plot displays the major patterns in the species data with respect to the environmental variables. Squares represent individuals scores, while crosses indicate the alleles of the outliers (*SmaUSC-E4*, *SmaUSC-E7* and *Smal-152INRA*). Alleles most important for environmental correlation are labelled. The environmental variables are represented as vectors and only those variables are illustrated which were identified by forward selection: SSS = Sea Surface Salinity, SST = Sea Surface Temperature, SBT = Sea Bottom Temperature, BSS = Bottom Shear Stress, O<sub>2</sub> = oxygen concentration, PYC = depth of pycnocline. The length of the environmental vectors indicates its importance to the ordination.

## DISCUSSION

The strength of the present study is twofold. Firstly, we performed an independent assessment of the effect of environmental and spatial variables on both neutral and outlier loci. An approach for the disentanglement of statistically significant genetic differentiation from biologically meaningful populations (Waples 1998; Knutsen *et al.* 2011). Secondly, in contrast to most population genetic studies, our samples are uniformly distributed across the landscape, reflecting the fairly continuous distribution of turbot, rather than a patchy pattern (Schwartz & McKelvey 2009). Accordingly, this sampling scheme enhances our capability to infer processes shaping population structure (Manel *et al.* 2010; Dray *et al.* 2012). A total of three distinct genetic clusters were identified across the Northeast Atlantic Ocean. Three loci showed elevated  $F_{ST}$  values indicating possible divergent selection in a genomic region close to these loci. Seascape genetic analyses suggest that both environmental and spatial heterogeneity are important explanatory factors of divergent selection at these loci. Furthermore, temporal variation seems to play an important role, especially in the Baltic-North Sea transition area. This temporal variation is most likely attributed to unstable environmental conditions as inflow of salt water into the brackish Baltic Sea varies between years. Below, we first describe the effect of genotyping the geographical population structure of turbot with neutral microsatellite markers and putative outlier loci. Secondly, we partition the neutral and adaptive population structure of the Baltic and North Sea region into spatial, environmental and temporal components with seascape genetics. The effect of each component is discussed. Finally, we discuss the correlation between environmental variables and outlier loci in the context of adaptation in marine environments.

### Combining neutral and selected loci to assess population structure

Neutral population structure serves as an indicator for genome-wide levels of genetic variation as this integrates the effects of neutral evolutionary forces and demographic history. Screening the 'neutral' marker set on turbot revealed a hierarchical structure with clear separation between a core Northeast Atlantic group, a Baltic Sea and an Irish Shelf group. Genetic divergence between Baltic and Atlantic individuals is consistent with earlier findings on turbot (Nielsen *et al.* 2004), and has been well described in other marine species (see review by Johannesson & André 2006; Poulsen *et al.* 2011; Limborg *et al.* 2012).



Despite the short geological history of the Baltic Sea (8000 years), the basin seems to act as a refuge for unique evolutionary lineages (Johannesson & André 2006), explaining the observed neutral genetic divergence. The status of the Irish Shelf population, however is more ambiguous. On the one hand, genetic differentiation of Irish Sea populations has been described in amongst others flatfish (Walton 1997; Coscia *et al.* 2012; Cuveliers *et al.* 2012); which has been attributed to the presence of an ancestral population (Kettle *et al.* 2011). Other studies have failed to detect differentiation with neutral loci in other flatfish species with a distribution similar to turbot (e.g., plaice *Pleuronectes platessa* (Was *et al.* 2010) and flounder (Hemmer-Hansen *et al.* 2007b)). Detecting such historical barriers is possible if past and/or present day barriers to dispersal act together to promote genetic differentiation (Bierne 2010; Bierne *et al.* 2011). However, variability in levels of gene flow between populations reduces the ability to pick up such differentiation, as a small number of reproducing migrants could wipe out most genetic evidence of stock structure (Waples 1998; Hauser & Carvalho 2008). Tagging studies on plaice have revealed migration patterns from the Irish Sea up to the southern North Sea (Dunn & Pawson 2002; Roel *et al.* 2009). The Bayesian analyses suggest similar movements for turbot (Figure 2). Thus, these migration events could explain why differences are observed with regards to the isolated character of the Irish Shelf, especially with neutral loci. Overall, the patterns we find with our neutral markers is consistent with previous findings and divides the Northeast Atlantic Ocean according to three main populations.

Three loci and their associated genomic regions were identified to be influenced by positive selection, two of which had been identified before by Vilas *et al.* (2010). Population genetic analyses confirmed the significant differentiation of the Baltic Sea population. Furthermore, the entrance of the Baltic Sea represents a sharp salinity transition, potentially enhancing local adaptation. Bierne *et al.* (2011) showed that tension zones resulting from genetic incompatibilities between populations with different genetic backgrounds often stabilize at natural environmental barriers such as observed at the entrance to the Baltic Sea, making it difficult to determine whether outlier loci occur as a result from environmental selection or are due to endogenous forces such as pre- and postzygotic incompatibilities. However, the patterns observed with loci putatively influenced by environmental selection (Table 3) suggest that drivers of divergence are neither the same across loci (Table S4) nor are they restricted to the strong environmental clines observed at the entrance to the Baltic Sea. Therefore, we argue that it is unlikely that these loci, or their genomic region, are merely a result of genetic incompatibilities between populations (Bierne *et al.* 2011).

Nevertheless, the substantial difference between Baltic and Atlantic populations probably results from both isolation and bottlenecks as demonstrated by the neutral loci, as well as environmental selection on adaptive traits (Johannesson & André 2006; Bierne *et al.* 2011).

In addition, outlier loci revealed a subtle break in the North Sea, which has rarely been detected before. The break may be attributed to the Friesian Front located north of the Dutch coast; it represents an area with a sharp cline in oceanographic conditions (Otto *et al.* 1990). Fronts represent a shift in temperature, salinity and food availability, which may influence the distribution of marine organisms (Galarza *et al.* 2009a; Galindo *et al.* 2010; Huret *et al.* 2013). Previously genetic differentiation within the North Sea has been suggested in Atlantic cod by Hutchinson *et al.* (2001), but see Nielsen *et al.* (2009a) and Poulsen *et al.* (2011). Furthermore, Larmuseau *et al.* (2010) also observed differentiation between northern and southern North Sea samples due to local adaptation to water turbidity at the rhodopsin gene. Hence, illustrating that local selection pressures may overcome the homogenizing effects of high gene flow (Yeaman & Otto 2011; Bradbury *et al.* 2013).

### Neutral and adaptive seascape genetics

Several studies have previously focused on the establishment of a link between environmental variability and candidate gene markers (Larmuseau *et al.* 2010; Lasky *et al.* 2012; DeFaveri *et al.* 2013), while others reported a strong relationship with neutral genetic differences in fish populations (McCairns & Bernatchez 2008; DeFaveri *et al.* 2013). Here, associations between adaptive genetic variation and seascape components were an order of magnitude higher than neutral variation (Tables 2 and 3), illustrating that divergent selection is counteracting the overall homogenizing effect of gene flow (Nielsen *et al.* 2009b; Hansen *et al.* 2012; DeFaveri *et al.* 2013). Nonetheless, it remains difficult to clearly disentangle the effect of spatial and environmental factors as they explained roughly similar proportions of the adaptive genetic variation (10.3% and 8.7%, respectively) as discussed below.

The contribution of spatial variation is most likely due to population structure generated by geographical distance (Gaggiotti *et al.* 2009; Gavilanez & Stevens 2012). Classical analytical approaches such as Mantel tests failed to find significant signals of isolation-by-distance in turbot (data not shown). This suggests that spatial variation may also reflect additional independent variation related to dispersal dynamics (Dormann *et al.* 2007; Gilbert & Bennett 2010; Manel *et al.* 2010). Accordingly, genetic variance partitioning showed that a large portion of microsatellite variation explained by the environment was also spatially structured.

Between basins, environmental variables explained different proportions of outlier microsatellite variation. Within the Baltic Sea, this amounted to 9.5% of the outlier genetic variation, while in the North Sea this was limited to 2.3% (Tables 2 and 3). The continuous selective pressure in the Baltic Sea, potentially resulting in different life history traits for Baltic turbot (Nissling *et al.* 2006; 2013; Wilczek *et al.* 2009), may contribute to relatively stronger local adaptation and thus stronger genetic-environmental associations (Hansen *et al.* 2012; DeFaveri *et al.* 2013; Teacher *et al.* 2013). Additionally, turbot in the transition zone may become homogenized by dispersal events from the North Sea. The North Sea is characterized by subtle environmental clines, possibly resulting in the low observed levels of environmental correlation. Nonetheless, the lower resolution may also result from a sampling artefact, as samples are relatively sparse in the northern North Sea (Figure 1), which mirrors the current scarcity of turbot in this part of the North Sea (Kerby *et al.* 2013). Moreover, repeatedly sampling the same population limits the variation in environmental samples and increases the share of total genetic variation found within populations (Lasky *et al.* 2012). The different environmental heterogeneity within each basin and at their transition strongly influences our ability to associate genetic variation with environmental parameters. Increasing the number of potentially adaptive markers may further allow for a better understanding of the mechanistic processes behind the observed environmental association. Alternatively, the inclusion of additional environmental variables in the North Sea may help pinpoint the actual drivers of genetic selection.

In addition to the spatial and environmental associations, a small but significant temporal correlation was observed with both marker panels. It was found to be largest in the Baltic Sea, as indicated by Nielsen *et al.* (2004) and Florin and Höglund (2007). Such temporal variation may have various causes (Waples 1989): (i) technical artefacts such as scoring errors and large allele dropout (Bonin *et al.* 2004; Nielsen *et al.* 2004); (ii) non-random sampling of individuals (Allendorf & Phelps 1981), and (iii) temporal fluctuations in allele frequencies (Jorde & Ryman 1995; Planes & Lenfant 2002; Pujolar *et al.* 2006). However, the larger proportion of temporal variation in the Baltic Sea, driven by the temporally replicated sample from the Belt Sea, suggests a strong influence from the unstable environmental regimes over the years, depending on the variable inflow of salt-water from the North Sea (Fonselius & Valderrama 2003; Florin & Hoglund 2007). Additionally, dispersal of flatfish larvae and/or migration of spawning adults between the two basins are facilitated in years with high saline water inflow and lower oxygen depletion (Florin & Hoglund 2007). In contrast, the northern Baltic and Bothnian Seas have a relatively stable temporal pattern for parameters such as temperature, salinity and oxygen concentration, enabling local populations to adapt environmentally.

The environmental heterogeneity observed at the entrance of the Baltic Sea and the associated migration events may lead to temporal heterogeneity. A similar suggestion was made to explain the different environmental-genetic association of the sand goby at the rhodopsin gene throughout the Baltic Sea (Larmuseau *et al.* 2010).

### Adaptation to marine environments

Salinity and temperature explained the largest portion of microsatellite variation. The finding that only presumably adaptive loci correlate with environmental factors illustrates that divergent selection may be an important force, despite the assumed high levels of gene flow (Nielsen *et al.* 2009b; Hansen *et al.* 2012). Acknowledging the possibility that temperature and salinity are merely correlated with other environmental selection forces is partly illustrated by the correlation with depth of the pycnocline and stratification with *SmaUSC-E7* and *SmaUSC-E4* (Table S4).

Temperature is a key environmental factor, as it affects metabolism and is expected to affect a range of physiological pathways driven by a multitude of genes. The sequence containing *SmaUSC-E4* shows a strong homology with the  $\beta$  2 microglobulin gene (E-value  $5.E^{-86}$ ), which encodes a protein closely associated with the MHC-I complex essential for antigen presentation and the subsequent adaptive immune response to pathogens (Millán *et al.* 2010). Significant variation in  $\beta$  microglobulin expression has been reported in Atlantic cod subjected to different temperatures (Pérez-Casanova *et al.* 2008). Pathogen distribution is affected by environmental patterns, particularly temperature (Kales *et al.* 2006); changes in temperature may greatly influence patterns of genetic variation in immune genes. Salinity has also been implicated in pathogen distribution (Park & Choi 2001), which may be associated with adaptive variation at immune genes because of the differences in this parameter between the Baltic Sea and the other areas sampled.

Locus *SmaUSC-E7* is associated with the fibroblast growth factor (FGF) receptor substrate 2 (E-value  $2.E^{-39}$ ). FGF receptors are involved in many biological processes during embryo development and the adult stage, including morphogenesis, cell proliferation and lipid metabolism, all related to some degree with growth (Groth & Lardelli 2002; Liu *et al.* 2013). As such, a significant association for this markers with growth-related traits was found by Sánchez-Molano *et al.* (2011). Habitat characteristics which have been demonstrated to influence muscle growth include hydrodynamics (Johnston *et al.* 2011) and temperature (turbot: Imsland *et al.* 1996; European sea bass *Dicentrarchus labrax*: Pavlidis *et al.* 2000; Saillant *et al.* 2002; sole and plaice: Teal *et al.* 2012).

Moreover, the effect of salinity on food intake and food conversion indirectly also affects growth (Gaumet *et al.* 1995; Boeuf & Payan 2001; Imsland *et al.* 2001b). Although no phenotypes of the analysed fish species are available, growth differences have been described in turbot populations between the Baltic Sea and the North Sea (ICES 2012b; van der Hammen *et al.* 2013), and between two close-by localities off Norway (Imsland *et al.* 2001a). The influence of both temperature and salinity has also been suggested to shape adaptive genetic diversity among Atlantic herring (Limborg *et al.* 2012; Teacher *et al.* 2013) as well as other marine species (Mäkinen *et al.* 2008; Bradbury *et al.* 2010; DeFaveri *et al.* 2013).

## Conclusion

Comprehensive sampling throughout the North-eastern Atlantic revealed a clear neutral genetic structure in turbot. Applying loci located in genomic regions potentially influenced by selection, increased our ability to identify evolutionarily significant population units (Funk *et al.* 2012). This study has spotted a break in the North Sea that has not been reported before and is only detected with outlier loci. Although outlier loci may be the result of endogenous or exogenous processes, seascape genetic techniques unveiled a strong signature of environmental selection at these candidate regions. We found that adaptation to local temperature and salinity conditions in the Baltic region is the most likely explanation for the existing genetic structure. Within the North Sea, evidence for natural selection was weak, but we cannot exclude that this is due to either weak selective forces or the differential historical background. In general, seascape genetic approaches aid in exploring how genetic discontinuities are shaped by environmental features, and highlight the importance of more comprehensive sampling. Future research will benefit from the use of gene-associated markers in combination with seascape variables, as they provide a powerful means for uncovering the processes leading to adaptive divergence. The biological relevance of the break in the North Sea should be investigated more closely in other marine species, particularly those where expanding genomic resources are linked with available ecological, demographic and physiological information (Nielsen *et al.* 2009b; Miller *et al.* 2011; Evans & Hofmann 2012). Being able to understand the association between ecological and life history variation, and neutral and adaptive divergence, will allow us to maintain genetic diversity and define biologically relevant population units more effectively, including for a broad array of exploited taxa.

## ACKNOWLEDGEMENTS

The collection of biological material was possible with the generous help of M. Storr-Paulsen, C. Reedtz Sparrevojn and F. Ivan Hansen at the Institute for Aquatic Resources (DK), I. Holmes and J. Ellis at Cefas (UK), D. Stokes and R. Bunn at the Irish Marine Institute, L. Bolle, J.J. Poos and I. De Boois at IMARES (NL), T. Saat, R. Eshbaum and K. Jürgens at the Estonian Marine Institute. Sampling in Sweden was done with help of M. Cardinale, F. Vitale, B. Bland and A.-B. Florin at the Department of Aquatic Resources of the Swedish University of Agricultural Sciences. We also thank J. Höglund at the Department of Population Biology, Uppsala University and A. Nissling at Gotland University, N. Probst and C. Stransky at the Johann Heinrich van Thünen Institute of Sea Fisheries (D), and K. Coull and C. Needle at Marine Scotland. Finally, we thank M. Vera and C. Bouza at the University de Santiago de Compostela (SP). GEM was a postdoctoral research fellow at the Fund for Scientific Research, Flanders (FWO) during the writing of this article. JAMR is funded by a EU Marie Curie Fellowship (IEF 300256). Research was financially supported by ILVO grants. We appreciate the assistance from F. Van den Broeck, B. Van Elslander and K. Vanhalst, and the help of N. de Hauwere and A. de Backere with ArcGIS. This paper greatly benefited from comments of E. Diopere, I. Coscia and four anonymous referees.



# Chapter 4

## Comparative population genetics

Foto: © Karl Van Ginderdeuren





# Chapter 4

## Evaluating common environmental and biological drivers of population structure in commercial flatfish species

### ABSTRACT

Identification of genetic discontinuities in marine species is crucial when developing conservation management strategies. The great variety of structuring displayed by species underlines the need to identify common environmental drivers of population structure. Here, we investigated the link between microsatellite allele frequencies, environmental factors and various life-history traits in brill, turbot and sole, three flatfishes co-occurring in the Northeast Atlantic Ocean. A total of 2897 individuals were collected at 320 unique locations. Using landscape genetics analyses, we identified a common gene flow barrier represented by the Friesian Front in the North Sea. However, different levels of differentiation were observed for each species. Turbot displayed the highest level of genetic differentiation, while brill was nearly panmictic. We suggest that the level of differentiation depends on the synergy between the front and species-specific spawning behavior. Considering life history traits of several species when investigating the effects of fragmentation allows inferring conservation needs at the community level. These results imply that the current management units for flatfishes should be revised, following the example of turbot. Subsequently, all other flatfish will benefit from the actions taken for this most vulnerable species.

## INTRODUCTION

The sizeable decrease in fisheries yield, poor recovery of fish stocks after fishing closures, and altered interspecific interactions suggest that fisheries science and management are not accounting for all relevant factors that influence the dynamics of aquatic ecosystems (Kenchington *et al.* 2003; Francis *et al.* 2007; Costello *et al.* 2012). In the last decade, the proper identification of population structure has proven key for the effective management of exploited species (Ward 2000; Reiss *et al.* 2009; Dann *et al.* 2013). Yet, for many exploited species this type of data is lacking, with management relying on political boundaries (Reiss *et al.* 2009). Two problems are associated with the mismatch between management and biologically relevant units. First, genetically homogenous populations can overlap several management zones, which are assessed independently, leading to misinterpretation of harvest statistics. Second, genetically heterogeneous populations can have overlapping distributions within management zones. In this case, the less productive populations are more susceptible to local extinctions in such circumstances (Ward 2000; Reiss *et al.* 2009; Roy *et al.* 2012). These seemingly small losses can have irreversible consequences on the functional role of the species within the ecosystem and on long-term viability, as the level of genetic diversity of each population may consist of unique genetic combinations important for future adaptation to changing conditions (Schindler *et al.* 2010; Roy *et al.* 2012; Dann *et al.* 2013). Hence, management plans need first to identify population structure and understand what factors shape this structure to allow the resilience of different populations under continuous harvesting (Reiss *et al.* 2009; Schindler *et al.* 2010; Dann *et al.* 2013).

Disentangling the proportional influence of evolutionary vs environmental forces effectively affecting the population structure of marine organisms in a seemingly homogenous ocean has always revealed complicated. However, patterns of biologically meaningful genetic structure have recently been identified in various commercial species (*Merluccius merluccius* (Milano *et al.* 2011; Pita *et al.* 2011); *Gadus morhua* (Jakobsdóttir *et al.* 2011); *Clupea harengus* (Teacher *et al.* 2013); and *Solea solea*: (Cuveliers *et al.* 2012)). These studies showed that barriers to dispersal mainly influence the spatial distribution of genetic diversity. Oceanographic features, such as fronts and eddies, may represent strong barriers species wide (Galarza *et al.* 2009a; Woodson *et al.* 2012).

The effect of these migration barriers on population structure depends on species-specific traits (Fox *et al.* 2000; Galarza *et al.* 2009a) as illustrated by genetic studies of phylogenetically closely related species. Whereas plaice (*Pleuronectes platessa*) seemingly represents one panmictic population on the European continental shelf (Was *et al.* 2010), flounder (*Platichthys flesus*) lives in subgroups, even on a small spatial scale (Hemmer-Hansen *et al.* 2007b; Larsen *et al.* 2007). Similarly, species within the same family can exhibit differences in genetic divergence (Sparidae (Bargelloni *et al.* 2003); Scophthalmidae (Danancher & Garcia-Vazquez 2009); Mullidae (Galarza *et al.* 2009b)). Finally, considerable differences in spatial structures have been found within the same species due to differences in life history traits (Pardoe & Marteinsdóttir 2009; Jakobsdóttir *et al.* 2011). All these studies unveiling a great variety of genetic structure in demersal species give rise to questions whether common patterns can even be found on a taxon-based level, when geographical features may determine genetic discontinuities by potentially reducing gene flow, will species-specific reinforce such barrier (Raeymaekers *et al.* 2008; Galarza *et al.* 2009a; Blanchet *et al.* 2010)

Here, we aimed at determining whether differences in the biology, life-history traits and dispersal capacity of three highly exploited demersal flatfish species may result in differences in the distribution of genetic variation across the Northeastern Atlantic Ocean. The three model species of this study are brill (*Scophthalmus rhombus*), turbot (*S. maximus*) and sole (*Solea solea*), all species highly exploited in the North-Atlantic and requiring better definition of management units at smaller scale. Like most marine fish, although the juvenile pelagic stages represents their most important dispersal mechanism, strongly influenced by oceanographic processes (Fox *et al.* 2000; Cowen *et al.* 2006; Cowen & Sponaugle 2009; Galarza *et al.* 2009a), the relationship between potential and effective dispersal (with gene flow) is more complex than expected (Galarza *et al.* 2009a; White *et al.* 2010a; Selkoe & Toonen 2011). Other factors than the commonly investigated traits (such as egg type, pelagic larval duration and inshore-offshore spawning location) might be at play and hence influence the level of differentiation.

The main objective of this study was to investigate the genetic structure of three commercial flatfishes, to detect common environmental and biological factors influencing the distribution of genetic diversity within and among putative populations. Our study combines a fine-grained sampling design with environmental data to increase the chance of detecting subtle patterns of population subdivision. Considering the similarity in life history traits, we hypothesized that the genetic characteristics of brill should be more similar to turbot than sole (Table 3). The main difference between turbot and brill lies in their spawning period (van der Hammen *et al.* 2013), whereas both turbot and brill differ from sole in the spatially restricted spawning location of the latter (Rijnsdorp *et al.* 1992; Fox *et al.* 2000). Because all other traits are similar, we hypothesize that spawning time and location may be important factors to explain possible differences in population structure. Our results are discussed in the light of a new general to integrate knowledge about the interaction among life history traits, genetic divergence and the environment into an adaptive management framework.

## **MATERIALS AND METHODS**

### **Sampling design**

The sampling design of brill (Scophthalmidae; Teleostei) was optimized to cover its natural range across the Northeastern Atlantic Ocean (Figure 1). Two types of scales were considered: (1) a spatial scale covering the natural distribution and (2) a short-term temporal scale at most sites. In total 879 brill samples, pooled into 12 ICES fisheries rectangles, were analyzed (Table 1). For turbot and sole, individual genotypes were used as described in (Vandamme *et al.* 2013) and (Cuveliers *et al.* 2012), respectively. Samples of turbot that did not match the distribution of either brill or sole (e.g. inner Baltic Sea, Iceland and Norway) were not included. Similar to brill, the genotypes of sole and turbot samples were lumped into “populations” represented by ICES fisheries rectangles. In total, 2897 individuals were genotyped at 320 unique sampling locations.

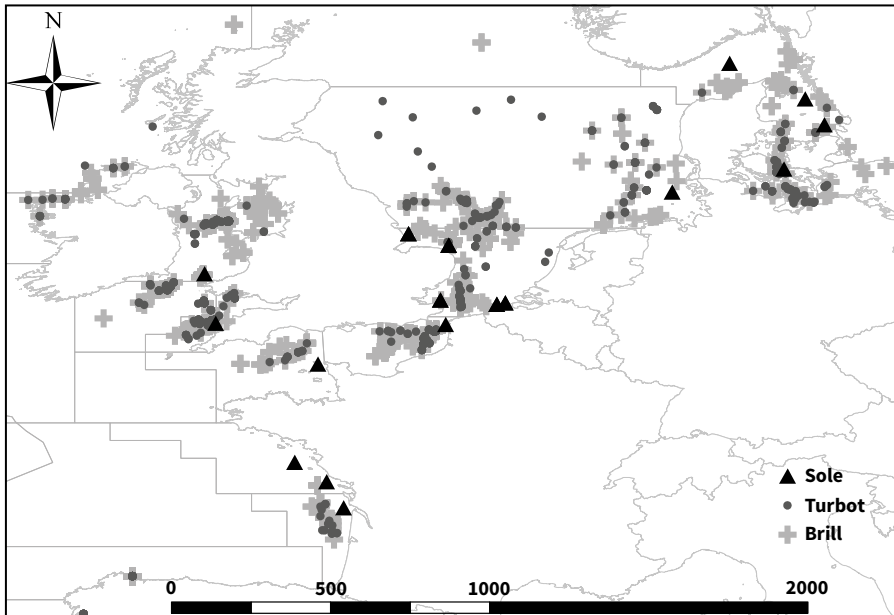

Figure 1 Sampling sites of turbot, brill and sole in the Northeast Atlantic Ocean

## DNA extraction and microsatellite genotyping

The Nucleospin Tissue extraction kit was used for DNA extraction (Macherey Nagel GmbH, Düren, Germany). Brill samples were genotyped at 19 microsatellite loci, including two markers from Iyengar *et al.* (2000) (*Sma5-111INRA*, *Sma1-152INRA*), three EST-derived markers described in Bouza *et al.* (2008) (*SmaUSC-E2*, *SmaUSC-E32* and *SmaUSC-E41*) and 14 novel markers developed through 454 gDNA pyrosequencing as described in Molecular Ecology Resources Primer Development *et al.* (2012). Microsatellite markers were combined in three multiplex-reactions, each consisting of an initial denaturation step of 7 min at 95°C, followed by 30 cycles of 30 s at 95°C, 90 s at 54°C (multiplex 2 and 3) or 56°C (multiplex 1) and 60 s at 72°C after a final elongation of 30 s at 60°C, and cooled down to 10°C. Fragment analysis was performed on a ABI 3130 AVANT Genetic Analyzer (Applied Biosystems) using GeneScan-500 LIZ internal lane size standard. Allele sizes were determined using the Genemapper v 4.0 (Applied Biosystems). The TANDEM v 1.07 software was used for automated allele binning (Matschiner and Salzburger 2009). Quality assessment was performed on these genotypes.

None of the loci showed signs of linkage disequilibrium, but MICRO-CHECKER analysis found evidence for null-alleles at three loci: *ScoR7*, *ScoR10* and *ScoR15*. Locus *SmaUSC-E2* was almost completely fixed (number of alleles: 2) and due to its low informative status it was not considered in any statistical analysis. Genotypes were missing for locus *ScoR3* in two populations, which brings the total number of microsatellites considered in the analysis to 14. Once those markers were removed from the panel, all samples complied with Hardy-Weinberg equilibrium expectations. The final dataset of brill consisted of 14 microsatellite loci.

### Population genetic analyses

To allow a comparative population and seascape genetic analyses with brill, turbot genotypes based on 14 neutral microsatellites (Vandamme *et al.* 2013) and sole genotypes based on 10 microsatellite markers (Cuveliers *et al.* 2012) were included in the analysis. All analyses described below are original and have not been performed in the above mentioned publications. Multilocus genotypes were tested for deviations from Hardy-Weinberg equilibrium and linkage disequilibrium by using Fisher's exact test in GENEPOP v 4.2 (Raymond and Rousset 1995). Furthermore, randomization tests (4320 randomizations) for significance of  $F_{IS}$  (reflecting heterozygote deficiency/excess) were conducted using FSTAT v 2.9.3 (Goudet 1995). A suite of summary statistics was calculated to quantify the information content across loci. For each sample, the level of genetic variation was estimated as allelic richness (following El Mousadik and Petit 1996), number of alleles and observed ( $H_{obs}$ ) and expected ( $H_{exp}$ ) heterozygosities using the FSTAT v 2.9.3 program (Goudet 1995).

Genetic structure among populations within each species was investigated using two methods. First, population structure was investigated using standard analyses of global and pairwise  $F_{ST}$  between all samples (using Weir and Cockerham 1984 statistics) using FSTAT. Using the same software, temporal variability between years was assessed. Second, a Bayesian clustering analysis was performed on individual genotypes using STRUCTURE v 2.3.3 (Pritchard *et al.* 2000). The non-admixture model was used with spatio-temporal origin as prior information. For each simulation of  $K$  (1-10), 10 independent replicates were run. In total,  $10^4$  runs were used as burn-in, followed by  $10^5$  Markov Chain Monte Carlo (MCMC) iterations. The most likely number of clusters was selected by choosing  $K$  with the largest log-likelihood according to Evanno *et al.* (2005) implemented in the STRUCTURE HARVESTER v 0.6.92 web application (Earl & vonHoldt 2012)

## Patterns of population structure and spatial-environmental correlations

After characterizing the neutral genetic structure of the three target species, we investigated whether landscape features might explain additional subtle variation in allele frequencies among landscapes using redundancy analysis (RDA). RDA is a canonical extension of principal component analysis (PCA) in which the principal components produced are constrained to linear combinations of a set of predictor variables (Borcard *et al.* 2011; Garroway *et al.* 2011; Dray *et al.* 2012). The objective of this analysis was to identify the best ordination model that describes genetic similarities among landscape variables to better understand how spatial, environmental and temporal heterogeneity affects gene flow in flatfish species. Spatial variables were represented by Moran's eigenvector maps (MEMs), calculated from a distance based matrix of the geographic shortest waterway distance between sampling points, also known as PCNM variables (Borcard & Legendre 2002). To test for temporal stability, we transformed the sampling year variable into a matrix with each year organized in a column, indicated for each sample what year it was sampled with a 1 (and 0 for the other years). Lastly, nine environmental predictor variables were downloaded from the WGOOFE ICES working group website ([groupsites.ices.dk/sites/wgoofe](http://groupsites.ices.dk/sites/wgoofe)). These variables encompasses: sea surface and sea bottom temperature (SST and SBT, respectively, °C), salinity of the surface and bottom waters (SSS and SBS, respectively, psu), bottom dissolved oxygen concentration ( $O_2$ ,  $ml.l^{-1}$ ), net primary production (PP; expressed as  $g\ C.m^{-2}.d^{-1}$ ), bottom shear stress (BSS,  $m^2\ s^{-2}$ ), depth of pycnocline (PYC, m) and a density based stratification index (STRAT,  $kg.m^{-3}$ ) for the area of the greater North Sea (including English Channel, North Sea and Skagerrak). For more detailed information on these variables see Schrum *et al.* (2003) and Vandamme *et al.* (2013).

Each individual sample was linked to the environmental data by extracting the value of the closest cell without extrapolation. As the raw environmental model available from the ICES-WGOOFE database has a fine grained geographical scale, each unique sampling location was assigned a unique value for each of the environmental variables tested. As annual estimates of environmental data may differ substantially from intra- and inter-species specific seasons potentially affecting the genetic variation, we calculated a monthly and yearly average over the available period 1980-2004. In addition, the yearly variance of each variable over the same time period was included to test whether large seasonal variation of a specific variable might affect the level of genetic variation of each species differentially, leaving a total of 126 parameters to be tested.

In order to prevent over-fitting the model by including all these environmental predictors, we used a classical PCA method to screen for the major environmental gradients present in the data set (Figure 2, S1 and S2).

We tested the null hypothesis that space, time nor environment did contribute to explain neutral genetic variation. This was tested for significance using 1000 random permutations, applying the variance partitioning and the canonical redundancy analysis (RDA) implemented in the *VEGAN* package (Oksanen 2011). For significant RDA analyses, we applied forward selection implemented in the *PACKFOR* package (Dray *et al.* 2007), including a threshold of  $\alpha = 0.05$  and given the adjusted  $R^2$  parameter of the RDA with all variables included to obtain an unbiased selection (Blanchet *et al.* 2008). Forward selection corrects for highly inflated type I errors and overestimated amounts of explained variation. This reduced panel of explanatory variables was then used to recalculate the total proportion of genetic variation in the variance partitioning. For further details on the handling of explanatory and predictor data see Vandamme *et al.* (2013)



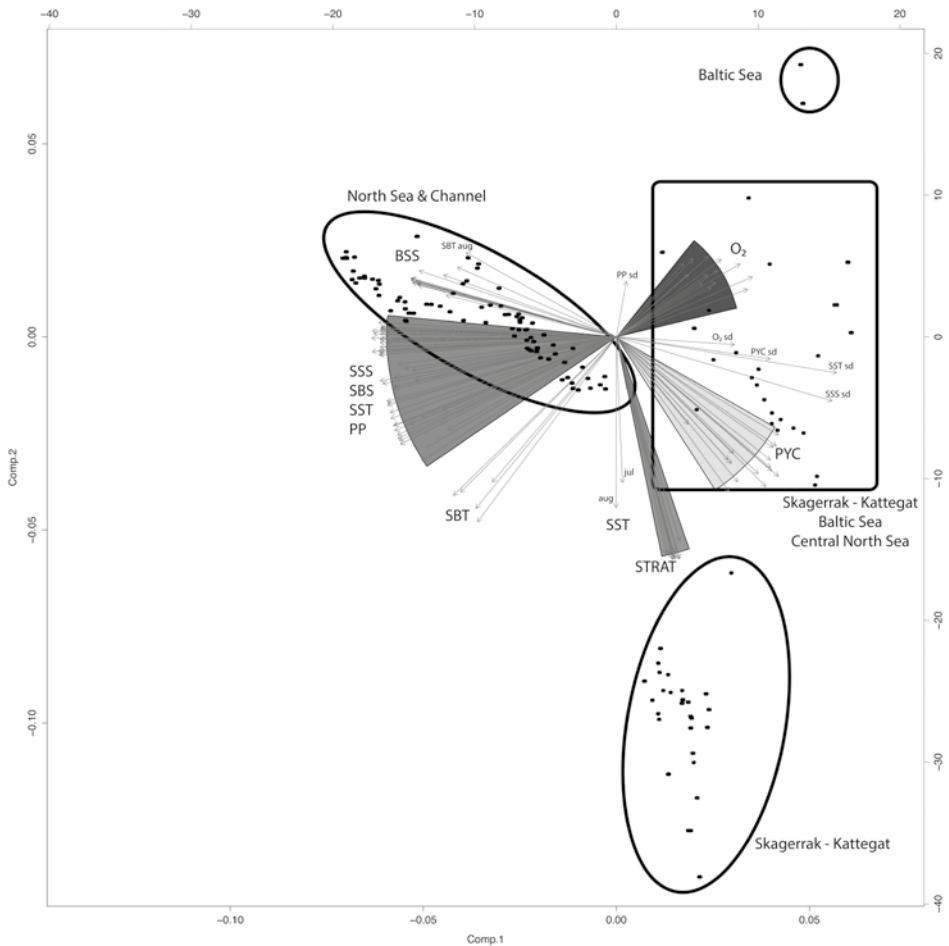

**Figure 2** PCA analyses conducted on turbot individuals from the Baltic, Skagerrak-Kattegat, North Sea and Channel. Using the environmental variables four clusters are identified separating southern North Sea and Channel individuals. Each arrow represents a monthly or yearly average or the standard deviation of an environmental variable. Each shaded triangle combines the different averages of each variable. Abbreviations for the relevant variables are temperature of the sea surface and sea bottom (SST and SBT, respectively), salinity of the surface and bottom waters (SSS and SBS, respectively), bottom dissolved oxygen concentration (O<sub>2</sub>), net primary production (PP), bottom shear stress (BSS), depth of pycnocline (PYC) and stratification index (STRAT).

**Table 1 Sampling information for sole, turbot and brill species including sampling ID, latitude (Lat), longitude (Long), number of samples (N), Estimates of genetic diversity presented are expressed in expected and observed heterozygosity (H<sub>exp</sub> and H<sub>obs</sub>, respectively) and allelic richness (AR).**

Geographical Region	mean Position			Turbot				Brill				Sole						
	Sample location	Lat	Long	Sample ID	N	H <sub>exp</sub>	H <sub>obs</sub>	AR	Sample ID	N	H <sub>exp</sub>	H <sub>obs</sub>	AR	Sample ID	N	H <sub>exp</sub>	H <sub>obs</sub>	AR
Transition Area	Belt Sea	54.5	11.2	BEL10	39	0.654	0.643	4.56	BEL10	16	0.759	0.769	6.34					
	Belt Sea	55.9	11.3	BEL09	26	0.667	0.623	5.08	BEL09	38	0.781	0.715	6.61	BEL07	43	0.729	0.741	5.94
	Kattegat	57.0	11.3	KAT09	15	0.642	0.642	4.79	KAT09	30	0.759	0.728	6.44	KAT07	87	0.738	0.732	5.77
	Skagerrak	58.2	11.0						SKR09	17	0.768	0.754	6.59	SKR07	36	0.722	0.712	5.77
North Sea	German Bight	55.5	6.7	ENS10	53	0.655	0.630	4.77	ENS10	25	0.743	0.670	6.28					
	German Bight	53.8	6.5						ENS09	15	0.752	0.751	6.84	ENS07	45	0.736	0.698	5.89
	Central North Sea	54.7	2.1	CNS10	14	0.655	0.684	4.59					CNS08	48	0.753	0.740	6.25	
	Central North Sea	51.7	2.2	CNS07	48	0.649	0.662	4.65	CNS07	66	0.764	0.739	6.40	CNS07	41	0.752	0.723	6.12
	Southern North Sea	52.5	1.9	SNS07	18	0.621	0.563	4.59					SNS07	301	0.770	0.724	6.24	
	Southern North Sea	51.8	1.8	SNS09	32	0.666	0.642	4.79	SNS09	42	0.761	0.751	6.28	SNS08	189	0.757	0.698	6.21
	Southern North Sea	52.2	2.4						SNS10	33	0.761	0.747	6.38					
English Channel	Eastern English Channel	50.4	0.2	EEC07	29	0.647	0.648	4.59	EEC07	37	0.777	0.745	6.49					
	Eastern English Channel	50.5	1.1	EEC09	51	0.674	0.658	4.90	EEC09	66	0.774	0.743	6.51	EEC08	51	0.751	0.701	6.09
	Eastern English Channel	50.0	-0.2						EEC10	44	0.778	0.744	6.49					
	Western English Channel	50.0	-2.8	WEC10	16	0.649	0.634	4.78	WEC10	35	0.777	0.745	6.39	WEC09	74	0.744	0.703	6.02

British Isles	Bristol Channel	50.7	-5.5	BCH07	16	0.644	0.674	4.59	BCH07	29	0.772	0.691	6.43	
	Bristol Channel	51.4	-4.7	BCH09	20	0.675	0.661	4.87	BCH09	17	0.763	0.743	6.56	
	Bristol Channel	50.8	-5.5	BCH10	43	0.662	0.634	4.74					72	
	South East Ireland	51.6	-6.0	SEI09	90	0.673	0.645	4.85	SEI09	78	0.770	0.721	6.34	
	Irish Sea	53.5	-53.0	IRS06	21	0.630	0.575	4.57						
	Irish Sea	53.6	-5.0	IRS07	20	0.625	0.642	4.62	IRS07	59	0.766	0.738	6.47	
	Irish Sea	53.6	-5.0	IRS09	82	0.678	0.677	4.81	IRS09	87	0.780	0.731	6.68	
	West Ireland	54.6	-9.0	WIR09	26	0.672	0.670	4.84	WIR09	29	0.780	0.797	6.66	
	West Scotland	55.4	-7.7						WSC09	19	0.759	0.764	6.57	
	Iberian Peninsula	Bay of Biscay	45.6	-2.1			0.652	0.600	4.80	BOB06	18	0.770	0.756	6.22
Bay of Biscay		45.2	-1.8	BOB07	25	0.680	0.673	4.75	BOB07	49	0.777	0.759	6.70	
Bay of Biscay		45.2	-1.8	BOB09	18	0.668	0.661	4.74					171	
North and North West Spain		43.7	-7.4	NWS00	27	0.668	0.677	4.79	NWS00	30	0.763	0.747	6.42	
Portuguese Coast		42.6	-8.8	POR00	19	0.603	0.550	4.80						88
														0.762
													0.759	
													0.725	
													6.15	

## RESULTS

### Genotyping data and genetic diversity

Expected heterozygosity estimates for Individual samples varied between 0.603 and 0.680 for turbot, 0.722 and 0.770 for sole, and 0.743 and 0.781 for brill. Between populations, heterozygosity varied most distinctively for sole, where samples from the Baltic transition area have a lower genetic variability. For turbot the lowest variability is observed in the North Sea and along the Portuguese coast, while the highest values are found off Ireland and in the Bay of Biscay (Table 1). Brill heterozygosity levels varied marginally between regions. Allelic richness (AR) was calculated for 8 individuals for all three species. Average allelic richness ranged among species between 4.74 in turbot to 6.48 in brill. Sole displayed intermediate levels of allelic richness (AR = 4.05). Between areas turbot displayed the highest AR in the Kattegat area (AR = 4.81), whereas for brill and sole the highest estimates were found off Ireland (AR = 6.53) and the Iberian Peninsula (AR = 6.15), respectively. More details about diversity measures are listed in Table 1. In accordance with the lowest levels of genetic diversity, the highest multilocus  $F_{ST}$  estimates were found in turbot ( $F_{ST} = 0.0056$ ; 95% CI = 0.0026-0.0084), whereas overall  $F_{ST}$  for brill was 0.0017 (95% CI 0.0002-0.0034). Moderate genetic differentiation was observed for sole ( $F_{ST} = 0.0024$ ; 95% CI = 0.0011-0.0038).

### Patterns of spatial population structure

Although global  $F_{ST}$  values were weak in all three species, there were marked and consistent differences in allele frequency among sites. Pairwise  $F_{ST}$  revealed a separate group of samples from the Skagerrak-Kattegat area in all species, but turbot. For turbot, a genetic group could be distinguished separating samples off the western Irish shelf. Pairwise estimates of population differentiation ranged for all species from zero to a maximum of 0.027 for turbot (WIR-ENS) and 0.01 for sole (KAT-BOB) remaining significant after Bonferroni correction. For brill no significant values could be observed after correcting for multiple testing, but the highest value was estimated between SKR and BOB06 ( $F_{ST} = 0.016$ ). Bayesian assignment tests indicated the presence of three genetic subpopulations ( $K = 3$ ) for both turbot and sole. Here, a clear separation between samples from the Skagerrak-Kattegat and other North-eastern Atlantic samples was observed (Figure 3).

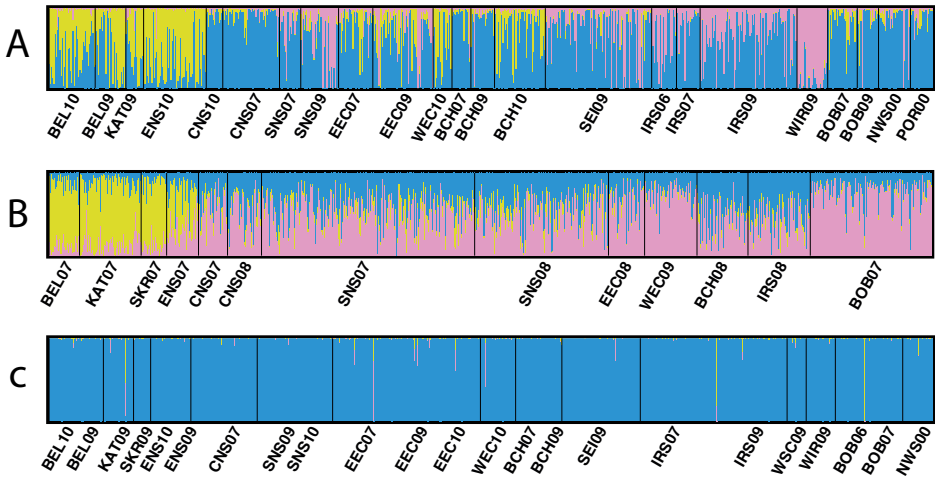

**Figure 3 Individual assignment based on Bayesian clustering method implemented in STRUCTURE. Each bar represents an individual with its probability of membership to one of the hypothetical clusters. Cluster membership was estimated for (A) turbot with 14 neutral loci, highest probability was found for  $K = 3$  clusters. (B) Illustrates cluster membership for sole with  $K = 3$  clusters, and (C) represents the highest probability for brill  $K = 1$  clusters. See Table 1 for more information on samples.**

Within the Atlantic ocean, assignment analysis with STRUCTURE revealed a subgroup with individuals caught off Ireland. For sole, this pattern is particularly driven by the sample from the Bristol Channel (BCH08). In contrast to turbot and sole, Bayesian assignment tests indicated that brill is not subdivided into genetically distinct subgroups (most likely  $K = 1$ , Figure 3). Therefore, in the case of brill subtle genetic patterns within a single population rather than between separate populations will be examined using the landscape genetic analyses.

## Landscape genetics

PCA of environmental conditions across individuals showed that the first principal component (PC I) explained 52% of the variation for turbot, and was positively correlated with oxygen concentration, depth of pycnocline and stratification, and negatively with primary production, temperature, salinity and bottom shear stress. PC II explained 18% of the variation, mainly representing seasonal patterns in temperature (Figure 2).

For brill PC I and PC II explained 60% and 13% of the variation, respectively. As for turbot, PC I was correlated with temperature, salinity, primary production, stratification, oxygen and depth of the pycnocline (Figure S1). For sole, the only variable correlated with PC I was bottom shear stress, while no variables were correlated with PC II (Figure S2). Based on these PCA results a reduced matrix of environmental variables was prepared including those variables that separates the individuals most distinctively. Ultimately, 26 environmental parameters were included among those were annual estimates and standard deviations of all nine variables. Monthly estimates were incorporated for various variables, such as oxygen concentration and primary production in May. For the latter, we also included the month of October. Bottom temperature was extended with monthly averages for August and January and surface temperature was extended with the averages for July and September.

Spatial and environmental variables accounted for the largest significant fraction of explained variation in sole and brill, even when each group of predictor variables was corrected for the correlation with any other group of predictor variable (Table 2). The effect of time was in both species non-significant and/or equal to zero. For turbot on the other hand, the effect of space was more than double the contribution of both environment and time, and the effect of time was more pronounced than the effect of environment, especially looking at the unique contributions of each predictor matrix. Over all species, the effect imposed by environmental variables was significantly different from 0 (Table 2), but the magnitude of these variables was variable between species. This means that not all species respond equally to these variables. Specifically, the effect size of environment was equally large for brill and sole ( $R^2_{adj} = 0.002$ ), while the contribution of environmental for turbot was double ( $R^2_{adj} = 0.004$ ). In contrast, when environmental variables were corrected for the spatial and temporal variables, the effect was nihil for turbot. Hence, illustrating a combined effect of environment and space.

Forward selection was applied to reduce the predictor variables to only those variables that significantly correlate with the observed genetic variation. Depending on the species, different spatial MEMs were associated with the genetic structure. The temporal variation was for both turbot and sole associated with one specific sampling year. Significant correlations with environmental variables were different for each species (Table 2). However, it should be noted that stratification and depth of the pycnocline, observed for brill and sole respectively, are associated oceanographical features. Water layers become homogenized due to turbulence until a certain depth. The upper mixed layer is characterized by being nearly uniform in properties such as temperature and salinity.

The bottom of the mixed layer is characterized by a gradient, where the water properties change. The depth at which the combined effect of temperature and salinity changes results in an abrupt density change or pycnocline. The stratification index gives the maximum of the vertical gradient. When the water is stratified, the pycnocline is well marked. These oceanographic features are strongly influenced by seasonality, as in fact the mixed layer depth is smaller in summer than in winter due to solar heating of the surface water. Within the North Sea, there is a clear horizontal separation between the southern North Sea (well mixed all the year) and central North Sea (mixed in winter, stratified in summer) (Becker 1990; OSPAR Commission 2000). For turbot, sea surface temperature of September seems to be associated with the neutral genetic variation.

**Table 2 Results of variation partitioning analysis showing the co-variables significantly associated with genetic variation in the three species. Analyses were conducted for the greater North Sea area, including the Eastern English Channel and the transition zone. Adjusted variance components ( $R^2_{adj}$ ) with their p-values ( $< 0.05$ ) are shown, presenting the unique and shared fractions explained by environment (ENV), space and time. Co-variables significantly associated after forward selection are reported (SST = Sea Surface Temperature, PYC = depth of the pycnocline and STRAT = stratification index).**

	Turbot		Brill		Sole	
	R <sup>2</sup> adj	p-value	R <sup>2</sup> adj	p-value	R <sup>2</sup> adj	p-value
N	230		368		720	
Total variation	997.26		2102.9		2892.3	
ENV	0.004	<b>0.003</b>	0.002	<b>0.001</b>	0.002	<b>0.001</b>
SPACE	0.012	<b>0.001</b>	0.004	<b>0.001</b>	0.001	<b>0.007</b>
TIME	0.005	<b>0.001</b>	0.000	0.677	0.001	<b>0.023</b>
ENV + SPACE	0.013	<b>0.001</b>	0.004	<b>0.001</b>	0.003	<b>0.013</b>
ENV + TIME	0.006	<b>0.002</b>	0.002	<b>0.022</b>	0.002	0.173
SPACE + TIME	0.015	<b>0.001</b>	0.004	<b>0.001</b>	0.002	<b>0.015</b>
ENV+SPACE+- TIME	0.016	<b>0.001</b>	0.004	<b>0.001</b>	0.003	<b>0.010</b>
ENV SPACE+TIME	0.000	0.330	0.001	0.076	0.002	<b>0.001</b>
SPACE ENV+TIME	0.010	<b>0.001</b>	0.003	<b>0.002</b>	0.001	<b>0.005</b>
TIME ENV+SPACE	0.003	<b>0.011</b>	0.000	0.401	0.000	<b>0.033</b>
ENV TIME	0.001	0.183	0.002	<b>0.001</b>	0.002	<b>0.001</b>
ENV SPACE	0.001	0.113	0.001	0.091	0.002	<b>0.001</b>
SPACE TIME	0.010	<b>0.001</b>	0.004	<b>0.001</b>	0.001	<b>0.003</b>
SPACE ENV	0.009	<b>0.003</b>	0.002	<b>0.007</b>	0.001	<b>0.005</b>
TIME ENV	0.002	<b>0.037</b>	0.000	0.706	0.001	<b>0.040</b>
TIME SPACE	0.003	<b>0.005</b>	0.000	0.422	0.001	<b>0.020</b>
Residuals	0.984		0.996		0.997	

**Forward selection**

ENV

SST  
sept 0.004 **0.003**

PYC **0.002 0.001**

STRAT **0.002 0.001**

SPACE MEM27 0.003 **0.010** MEM2 **0.001 0.008**

MEM8 0.005 **0.022** MEM16 **0.003 0.006**

MEM1 0.008 **0.015** MEM4 **0.004 0.033**

MEM11 0.010 **0.039**

MEM3 0.012 **0.030** **0.001 0.005**

TIME 2009 0.005 **0.001** - - - 2008 **0.001 0.019**



## DISCUSSION

This paper is one of the first attempts to compare the level of genetic diversity and structure and the association to biological/environmental factors in three co-occurring fish species in the Northeast Atlantic Ocean. The sampling strategy was designed to cover almost the entire natural range of each species and to provide detailed geographic, temporal and environmental data for the greater North Sea (including English Channel, North Sea and Skagerrak). Overall, populations showed relatively high levels of genetic diversity (Ward *et al.* 1994; DeWoody & Avise 2000) and were characterized by a weak genetic structure with some peculiarities for each species. The correlation between genetic data and landscape variables were remarkably similar in all three species. The findings represent a starting point in understanding potential genetic responses of demersal species to environmental and spatial (potentially dispersal limiting) variables. Therefore, they could provide tools for the definition of a provisional model for multiple-species resource management and conservation strategies (Funk *et al.* 2012; Moritz & Potter 2013; Nicholson *et al.* 2013). We predicted that the genetic patterns of brill should be more similar to turbot than to sole because of similarities in life history traits (Table 3). As discussed below, we show that this prediction does not hold. Both species show very different characteristics pointing to the need for species-specific precautionary management actions.

### Comparative genetic variability and population structure assessment

As expected, all three flatfish showed high levels of genetic variation (Table 1, DeWoody & Avise 2000). Only turbot showed intermediate values, similar to anadromous fish (DeWoody & Avise 2000). Between regions, lower levels of diversity were recorded for sole in the transition area between North Sea and Baltic Sea, an area that represents the peripheral population of this species (Johannesson & André 2006). In contrast, equal levels of genetic variability were observed for turbot in this area, most likely attributed to the existence of a contact zone (Nielsen *et al.* 2004; Vandamme *et al.* 2013). Opposed to sole and brill, turbot is well represented within the Baltic Sea. Therefore, in the Skagerrak-Kattegat area turbot can originate from two genetically distinct groups (each characterized by their specific allele frequencies) bordering the contact zone (Nielsen *et al.* 2003; Nielsen *et al.* 2004; Vandamme *et al.* 2013). For brill, the distribution of genetic variation was not influenced by geographical patterns.

Following expectations from the high genetic diversity, patterns of population structure were only obvious at large geographical scales. These findings agree with previous studies on sole and turbot (Cuveliers *et al.* 2012; Vandamme *et al.* 2013). Bayesian analyses showed that the best value of  $K$  according to the Evanno method occurred at  $K = 3$  in turbot and sole, but not in brill ( $K = 1$ ). At  $K = 3$ , a clear distinction between samples from the Baltic Sea and those off the Irish shelf occurred. Genetic differentiation between populations in the Atlantic Ocean and the Baltic Sea, have been well documented in the literature. It has been attributed to the stressful environmental gradient (see review Johannesson & André 2006; Larsen *et al.* 2012; Teacher *et al.* 2013). In the case of sole and brill, the location where the environmental clines, like temperature and salinity are strongest, also represents their distributional limit (see below, Gibson 2005; van der Hammen *et al.* 2013). Turbot, on the other hand is well adapted to these environmental stressors leading to a high variability in life history traits for the inner Baltic populations (Nissling *et al.* 2006; 2013). In addition, Bayesian analysis revealed the presence of another cluster comprising individuals caught off the Irish shelf for both turbot and sole. The isolation of Irish populations has been found in several marine species (Hemmer-Hansen *et al.* 2007b; Was *et al.* 2010; Cuveliers *et al.* 2012) and it was suggested that this genetic isolation of the Irish Sea could be related to the presence of a glacial refuge (Kettle *et al.* 2011). A strong oceanographic front at the southern entrance of the Irish Sea restricts contemporary gene flow such that it may preserve unique historical lineages and subsequently genetic differentiation (Bierne 2010; Bierne *et al.* 2011). Overall there is no significant genetic divergence observed between brill samples, leading to consider this species is panmictic over the studied scale using neutral markers. In summary, these flatfish species show despite their comparable life-history strategy different levels in genetic differentiation. The highest similarity regarding LHT is found between brill and turbot. Nevertheless, brill revealed to be almost panmictic while turbot clearly exhibited two discrete subpopulations: one in the Skagerrak-Baltic Sea and one off the Irish coast. To investigate whether the discrepancy in the level of genetic differentiation might be related to subtle differences in life history traits (influencing  $N_m$ , population size or exploitation level) we have applied seascape genetic analysis as further discussed below.

## Genetic and environmental correlates in space and time

We investigated the relationship between spatio-temporal environmental and genetic variation to detect biologically relevant genetic differentiation on a small geographic scale. The common pattern observed in the analysis reinforces the relevance of these results as the observed level of genetic differentiation between the individuals for each species was of the same magnitude (Table 2).

Correlation between geographic distance and genetic variation, commonly described as isolation-by-distance, is well defined in marine species (Bradbury & Bentzen 2007; Hellberg 2009; Cuveliers *et al.* 2012), and is often in the range of 0.2-0.7, which is comparable to our results. When corrected for temporal and environmental effects, space remained significant in all three species, with the largest contribution made by turbot (Table 2). Although geographic distance might generate genetic structure through neutral processes, it might provide an indication of co-varying environmental parameters (Dormann *et al.* 2007; Gilbert & Bennett 2010; Manel *et al.* 2010). Depth of the pycnocline and the density-based stratification index correlated significantly with genetic variation of sole and brill, respectively. The position in the water column where these clines are strongest indicate the barrier between well mixed and stratified water and is associated with frontal formation (Becker 1990; OSPAR Commission 2000). Within the North Sea, a very strong frontal zone is found at the Friesian Front (Otto *et al.* 1990), separating the southern North Sea (well mixed year round) and central North Sea (mixed in winter, stratified in summer) (Becker 1990). The influence of this frontal zone on populations could be twofold. First, it could represent a distributional limit to the northward movement of warm-adapted individuals as was suggested for plaice (Hunter *et al.* 2004). This impact on adult migration (Hutchinson *et al.* 2001; Charrier *et al.* 2007; Galarza *et al.* 2009a) may explain why the core distribution of sole and brill is situated in the southern North Sea (Gibson 2005; Kerby *et al.* 2013). Second, this barrier might affect larval distribution (Woodson *et al.* 2012). Sharp gradients are observed in nutrients, oxygen and chlorophyll concentration at these fronts, having foraging implications for the larvae (Pingree *et al.* 1978; Riegman *et al.* 1990). Interannual variation in the intensity and position of the front, and the associated temperature might influence the performance of the front as a barrier. Combined with the reproductive output of species (number of eggs, timing and frequency of reproduction), the front might significantly affect distribution patterns of the early life stages (Schunter *et al.* 2011; Woodson *et al.* 2012).

For turbot, neutral genetic variation is correlated with temperature. Besides the immediate influence of temperature on turbot physiology, this variable is also involved in frontal formation which might reduce migration and gene flow (Galarza *et al.* 2009a; Woodson *et al.* 2012; Vandamme *et al.* 2013). Unlike sole and brill, turbot is more tolerant towards extreme environmental conditions, as illustrated by the higher abundances at higher latitudes and the possible presence of a northern spawning location (Rae & Devlin 1972; Kerby *et al.* 2013; van der Hammen *et al.* 2013). Temperature mediated growth of juveniles and adults was observed in turbot (Imstrand *et al.* 1996; Árnason *et al.* 2009) and is also reflected in growth differences between the Baltic and the North Sea and the Bay of Biscay (van der Hammen *et al.* 2013). This implies that these fish may be adapted the lower temperatures (Vandamme *et al.* 2013).

Short term temporal genetic variation in demersal fish has been described before (Waples 1998; Nielsen *et al.* 2004; Florin and Hoglund 2007), especially in pelagic fish species (Lundy *et al.* 2000; Smith *et al.* 2001; Jørgensen *et al.* 2005). Although such variation might be the result of technical or sampling artifacts (Waples 1998; Nielsen *et al.* 2004), alternatively it might be a result of the specific spawning behaviour (Hedgcock & Pudovkin 2011). Turbot has the shortest spawning season (Table 3) and is a capital spawner (single spawning event) (Rijnsdorp & Witthames 2005; van Damme 2013). Taken together with low females densities at the spawning sites (van der Hammen *et al.* 2013), strong temporal variation might result from the interannual variation in the reproductive output of highly fecund adults. Depending on the number of successful reproducing adults, variation in allele frequency distributions might be picked-up in the following years (Nielsen *et al.* 2004; Florin & Hoglund 2007; Vandamme *et al.* 2013).

**Table 3 Overview of the main life history traits of demersal species widely distributed in the Northeast Atlantic Ocean and relative high abundances in North Sea.**

Species	<i>S. rhombus</i>	<i>S. maximus</i>	<i>Solea solea</i>	<i>Pleuronectes platessa</i>
Adult depth distribution	70-80 m <sup>1,2</sup>	70-80 m <sup>1,2</sup>	mainly < 50 m <sup>3,5</sup>	< 100 m <sup>4,5</sup>
Spawning location	offshore <sup>6,7,8</sup>	offshore <sup>6,7,8</sup>	inshore and restricted <sup>3,9</sup>	offshore and restricted <sup>10,11</sup>
Spawning time	February -August <sup>8,12</sup>	May-July <sup>8,12</sup>	March-May <sup>3,9</sup>	December-March <sup>10,11</sup>
Adult density at spawning site <sup>8</sup>	1 per 2 x 10 <sup>6</sup> m <sup>2</sup>	1 per 2 x 10 <sup>6</sup> m <sup>2</sup>	4 per 10 <sup>4</sup> m <sup>2</sup>	1 per 10 <sup>4</sup> m <sup>2</sup>
Nursery location	shallow coastal waters (1m) <sup>13,14,15</sup>	shallow coastal waters (1m) <sup>13,14,15</sup>	shallow coastal waters <sup>3,15,16</sup>	shallow coastal waters <sup>15,16,17</sup>
Larval duration	2 months <sup>18</sup>	68 days <sup>18,19</sup>	1 months <sup>3</sup>	3 to 4 months <sup>10</sup>

Superscript numbers refer to the following references: 1: Déniel (1981), 2: Felix et al. (2011) and references therein, 3: Rijnsdorp et al. (1992), 4: Wimpenny (1953), 5: Gibson (2005), 6: Rae & Devlin (1972), 7: Delbare & De Clerck (1999), 8: Van der hammen (2013), 9: Lacroix et al. (2012), 10: Rijnsdorp (1991), 11: Hufnagl et al. (2012), 12: Jones (Jones 1974), 13: Riley et al. (1981), 14: Gibson (1997), 15: Beyst et al. (2001), 16: Beyst et al. (1999), 17: van der Veer (2000), 18: Jones (1972), 19: Nisling (2006) Association between life history traits, environmental barriers and genetic structure.

## Association between life history traits, environmental barriers and genetic structure

The congruence of genetic breaks across species at the same geographic features suggests that those have a strong effect on the realized dispersal potential and hence on the genetic pattern. However, the impact of these barriers will be modulated by species-specific traits (Waples 1998; Blanchet *et al.* 2010; Jakobsdóttir *et al.* 2011; DeFaveri *et al.* 2013). An intermediate level of genetic differentiation was observed for sole, a species with the shortest pelagic larval duration (Table 3). Although turbot and brill show similar pelagic durations, the resulting pattern of genetic differentiation due to fragmentation is inverse, varying from a nearly panmictic population for brill, to a clear subdivision in turbot (Figure 3). This counter-intuitive result might suggest that larval duration is not the best life history trait to explain observed genetic divergence patterns (Galarza *et al.* 2009a; Sivasundar & Palumbi 2010). Other reproductive traits could be more important, such as spawning time and location, as was suggested by Hufnagl *et al.* (2012) who described that the connectivity between spawning and nursery areas was not only affected by the duration of the pelagic phase, but also the distance between these grounds. In addition, a recurrent theme in fisheries ecology is that spawning strategies have evolved such that larvae will be spawned in areas, which on average are suitable for their survival (Cushing 1990; Daan *et al.* 1990). To avoid inter-specific competition, each species has evolved their specific set of LHTs, causing differences in reproductive strategies (Gibson 2005).

The combined influence of hydrodynamics and spawning behaviour might explain why genetic differentiation is more pronounced in one marine species compared to the other. This has been illustrated for sole, plaice and cod in the Irish Sea (Fox *et al.* 2000). Where the timing and location of spawning cod is responsible for the retention of cod eggs by gyres and fronts, these oceanographic features have little effect on plaice as spawning occurs earlier in the year, before the gyre and front becomes established. For sole, the spawning grounds are located outside the frontal zones, so their effects are also minimized. However, their inshore location and subsequent short distance to the nursery grounds may result in the relative high genetic differentiation (as illustrated here and in Cuveliers *et al.* 2012).

Genetic studies on plaice have revealed the almost complete absence of substructure, except for a population north of the Faroe islands and along the Norwegian coast, which is induced by abrupt bathymetric gradients (Was *et al.* 2010). Genetic differentiation has been observed between spawning aggregations of cod in the North Sea (Hutchinson *et al.* 2001). However, due to the genetic differences between inshore and offshore spawning grounds of cod, some studies find genetic differences at small geographical scale (Knutsen *et al.* 2003; Jakobsdóttir *et al.* 2011; Knutsen *et al.* 2011) and others only observe genetic differentiation at large scales (Nielsen *et al.* 2009a; 2009c; Poulsen *et al.* 2011).

Expanding this hypothesis to our study, could explain the high differentiation found for turbot despite a long duration of the pelagic larval stage. Its time of spawning in the North Sea is consistent with the period of intense and consistent formation of the front (Figure 4). At the same time, wind-driven currents are less strong than in e.g. winter time, reducing drift of eggs and larvae (Riley *et al.* 1981; Otto *et al.* 1990; Van der Land 1991). Moderate frontal formation in early spring (March) and stronger currents, by contrast, allows for stronger mixing of larvae spawned at the various spawning grounds, which applies to brill (Figure 4). For sole, the inshore spawning locations and short distance to the nurseries may result in low connectivity between the different nurseries (Lacroix *et al.* 2012). To conclude, the integration of genetic patterns with knowledge on oceanography and reproductive strategies has enabled a better understanding of the species specific differences in population structure. Our comparative results provide a potential mechanistic explanation of the complex genetic results in many marine organisms and allows to make predictions towards biologically relevant management units.

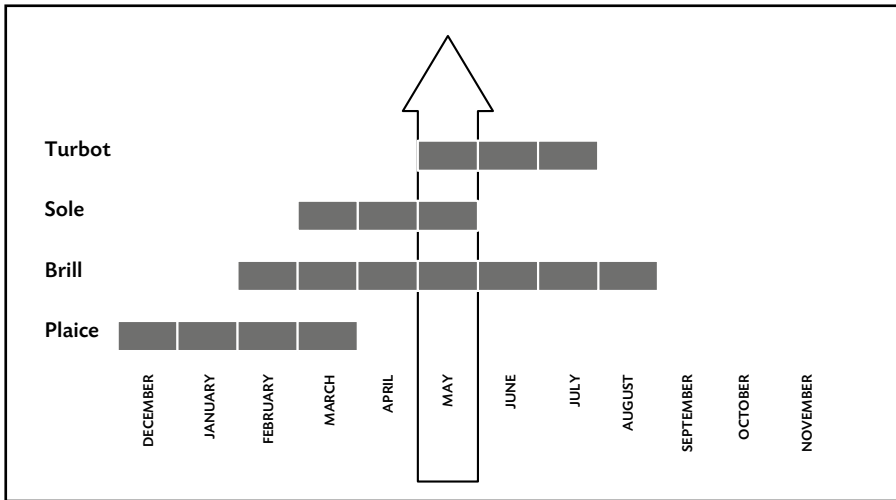

**Figure 4** Overview of the environmental barrier and species-specific spawning behaviour on the magnitude of genetic differentiation. For four flatfish species, turbot, sole, brill and plaice the spawning period is indicated by the grey bars. The arrow indicated the time of the year that the frontal zone in the North Sea is at its strongest. The direction of the arrow illustrates the increase of observed genetic differentiation with neutral genetic markers.

## Management implications

The impacts of fishing are obvious through increased mortality of target and non-target organisms. Turbot and brill represent two non-target species caught in the mixed demersal fisheries aiming for sole and plaice, with the main fishing area situated in the North Sea. Since 2013, individual assessments have been advised by ICES for all four species, with the North Sea representing one stock, except for brill. For brill, this stock also includes the eastern English Channel and Skagerrak-Kattegat ([www.ices.dk](http://www.ices.dk)). Based on the principles of maximum sustainable yield (MSY), a positive management advice is recommended by ICES for all species (except sole), meaning that the Total Allowable Catches (TAC) for the coming year will increase. However, our results illustrate that the existing single management unit does not reflect the true pattern of genetic divergence (Reiss *et al.* 2009; Ulrich *et al.* 2013) and is supported by other studies (Hunter *et al.* 2004; Hufnagl *et al.* 2012; Lacroix *et al.* 2012; Vandamme *et al.* 2013). The Friesian Front represents a gene flow barrier, separating the southern North Sea (ICES subdivision IVc) from the central and northern North Sea (ICES subdivision IVb,a). Hence, from a scientific point of view stock assessment analysis should be carried out on two separate units to take into account all levels of biodiversity (Waples & Gaggiotti 2006; Reiss *et al.* 2009; Ulrich *et al.* 2013).

Negative effects of fishing and changing environmental conditions may threaten the longevity of the populations (Funk *et al.* 2012; Roy *et al.* 2012; Moritz & Potter 2013). Although these effects may seem harmless at first as the biomass is considered high enough to support sustainable exploitation (see ICES advice 2013), changes in e.g. size and age at maturity have a large effect on the estimated harvest rates as these are important reference points in fisheries management (Laugen *et al.* 2014; Heino *et al.* 2013). More specifically to our case study, turbot is most sensitive to overfishing due to the low levels of genetic diversity, as was also illustrated by trend analysis of historical data sets in both the Baltic and North Sea (Cardinale *et al.* 2009; Kerby *et al.* 2013). Within the North Sea, a northern spawning stock has been already severely depleted (or even totally extinct) (Rae and Devlin 1972; Kerby *et al.* 2013), as turbot's distribution shifted as a result of climate change and fishing practices (Engelhard *et al.* 2011). This loss may potentially risk the entire northern North Sea population (Kerby *et al.* 2013) and with it the adaptive potential (Conover *et al.* 2006; Pinsky and Palumbi 2013). Within the Baltic Sea, the danger of losing a spawning population and the associated genetic diversity is even higher, as turbot is caught on the spawning grounds in a direct gillnet fishery (Cardinale *et al.* 2009; ICES 2012b). To compensate for the effect of the intense fishing practices turbot might have adapted in the Baltic Sea by increasing its reproductive investment compared to the North Sea (Nissling *et al.* 2013), which could explain the reduced size (Mollet *et al.* 2012; van der Hammen *et al.* 2013). This in turn affects the economic revenue of this fishery (Laugen *et al.* 2014). Furthermore, a decrease in size at maturity has been demonstrated in turbot (Jones 1974; ICES 2012b; van der Hammen *et al.* 2013). Although the effects of intense fishing practices on life history changes are hard to confirm genetically, remarkable shifts have been described for several commercially exploited marine species (Jørgensen *et al.* 2007; Allendorf *et al.* 2008; Heino *et al.* 2013), including sole and plaice (Mollet 2010; Mollet *et al.* 2012).

However, due to the complexity of the environment scientific research is characterized by uncertainties. Therefore, from a management point of view dividing the North Sea into two assessment areas seems unnecessary for several reasons. First, it is unclear whether these subpopulations have different life history traits, whose knowledge is limited anyhow, particularly for turbot and brill (van der Hammen *et al.* 2013). Second, spawning aggregations are considered crucial for the preservation of intraspecific biodiversity, even more so if the species is characterized by homing behaviour (McGlaulin *et al.* 2011). However, it is unknown whether the proposed two subpopulations are reproductively independent and should be managed accordingly (Waples & Gaggiotti 2006), as the spawning aggregations of turbot and brill are poorly documented (van der Hammen *et al.*



2013). Sole typically has inshore spawning location, with merely one spawning location north of the front, within the German Bight (Lacroix *et al.* 2012). Plaice on the other hand has several spawning locations north of the frontal zone, without a chance to find distinct genetic differences between these locations (Was *et al.* 2010). Third, splitting the North Sea in two management areas would be logistically very demanding and would be impossible to assess statistically due to limited data access, e.g., landings, individual length and age data (ICES 2012b).

If at the moment the stock assessment model lacks the capability to run two separate datasets in the North Sea, which would reflect the true population structure of the flatfish species studies, real-time monitoring is highly recommended (Wennevik *et al.* 2008; Volckaert 2012; Dann *et al.* 2013). This approach would allow to protect the weak stocks and harvest the strong ones. Furthermore, the use of demographic-genetic simulations may provide an effective way to estimate migration rates. Otherwise, the amount of genetic divergence at which populations become demographically independent (Palsbøll *et al.* 2007; Lowe & Allendorf 2010).

To conclude, our study demonstrates the importance of comparing several species and using synchronic sampling designs when investigating the interaction of environmental, space and life history on the connectivity between populations (Lambeck 1997; Roberge & Angelstam 2004; Moritz & Potter 2013; Nicholson *et al.* 2013). We were able to illustrate that depending on species-specific reproductive traits, such as spawning time and location, fragmentation is experienced differently by each species. Hence, precautionary principles or restoration programs should prioritize and target according to the biological specificity of each species. At the same time our approach contributes to a community based interpretation of shelf habitats. The oceanographic barrier influences multiple species and as such, could be used as a biologically relevant stock delineator within a multispecies management (Lambeck 1997; Roberge & Angelstam 2004; Nicholson *et al.* 2013). Because of limited resources and time for action, scientists and policy-makers never have all the information they need to protect biodiversity. So inevitably, we have to use a subset of species as proxies for how biodiversity as a whole will be affected by management (Nicholson *et al.* 2013). Within this subset, the species most sensitive to the threat, here turbot, should be used to define the minimum size of the management areas. When the most sensitive species are selected for management, the needs of all other naturally co-occurring species will be encompassed management (Lambeck 1997; Roberge & Angelstam 2004; Nicholson *et al.* 2013).

## **ACKNOWLEDGEMENTS**

The collection of genetic material was possible with the generous help of a long list of people from various fisheries institutes. G.E.M. was a postdoctoral research fellow at the Fund for Scientific Research, Flanders (FWO) during the writing of this article. J.A.M.R. is funded by a EU Marie Curie Fellowship (IEF 300256). Research was financially supported by an ILVO grant. We appreciate the assistance of W. Halfmaerten and Y. Aerbeydt with art work. At last this paper greatly benefited from comments by G. Lacroix and the anonymous referees.

# Part II

Foto: © Hans Hillewaert





Fish and fish products are more widely consumed than ever before; they represent a vital source of food and protein for billions of people worldwide (FAO 2012). The new techniques and commercial structures which have made this growing demand possible have also led to a massive increase in fishing pressure worldwide (Hutchings & Reynolds 2004; World Bank 2009; Anticamara *et al.* 2011). The loss of fisheries resources directly translates into damage to the entire environment (both directly and indirectly, through food chain and ecosystem interactions) (Pauly *et al.* 2002; Tremblay-Boyer *et al.* 2011; Branch *et al.* 2012; FAO 2012) and socio-economic losses (e.g., loss of income and employment, decrease of food security and drawback in poverty reduction). The losses are particularly acute in developing countries (Hanna 2003; Scheffer *et al.* 2005; Brans & Ferraro 2012). Although management authorities have set goals for the sustainable use of marine resources, mounting evidence shows that the conventional approaches to fisheries science and management is not always successful (Worm *et al.* 2009a; Branch *et al.* 2012 and references therein). This is exemplified in Figure 1, where the fishing fleet tends to have a significant overcapacity, which is partly due to governmental subsidies. Despite increased efforts and steadily upgraded fishing technologies, global marine catches have been stagnant for over a decade. Hence the global fishery economy is in deficit (World Bank 2009, but see Cardinale *et al.* 2013). Worldwide, only three areas, i.e. the shelves off Alaska, South Eastern Australia and New Zealand, have never been systematically overfished. Although some individual stocks in these areas have been overfished, as a whole those ecosystems have managed to avoid the systematic overfishing that characterizes the North Atlantic Ocean (Worm *et al.* 2009). In this regard, the European marine resources as a whole are no exception (COM 163 2009). Most stocks in European waters (88%) are still considered to be overfished and 30% of them are estimated to be unable to replenish (COM 163 2009). In this work the main problems associated with managing marine resources will be addressed, focusing on the Northeast Atlantic Ocean. Before entering into detail on the problems and challenges, we have to understand how fish stocks are managed. Worldwide commitments to adopt an Ecosystem Approach to Fisheries Management (EAFM) aim at supporting sustainable exploitation (Pikitch *et al.* 2004; Kraak *et al.* 2013).

This commitment will demand a reevaluation of management targets in the fishery and should help with the formulation of the role of managers<sup>1</sup> in a broader and long term vision. This vision will meet conservation objectives for the marine environment, taking into account socio-economic considerations (Garcia *et al.* 2003; Worm *et al.* 2009). The complexity of fisheries management make this a challenging task, which obviously can not be achieved overnight. European fisheries management is exceptionally challenging for several reasons (Rice & Cooper 2003; Sparholt *et al.* 2007; Wilson 2009). The European fishing industry is one of the most diverse and oldest in the world (European Commission 2009; Cardinale *et al.* 2013). The fleet ranges from the private recreational fisherman to multi-million-euro listed companies. The industry covers the entire market chain, from the point of capture through landing, transport, processing and distribution to final sale (European Commission 2009). Besides the industry, the fish stocks themselves are also highly variable, which is reflected in the diverse fishing interests both between as well as within Member States (Österblom *et al.* 2011). However, recent scientific literature shows that for the most important stocks, such as plaice (*Pleuronectes platessa*), sole (*Solea solea*), haddock (*Melanogrammus aeglefinus*), whiting (*Merlangius merlangus*) and saithe (*Pollachius virens*), the exploitation status has greatly improved in the Northeast Atlantic Ocean during the last 10 years (COM 278 2012; Cardinale *et al.* 2013). It illustrates that actions already implemented have led to an improvement in the status of many commercially important fish stocks (Worm *et al.* 2009; Cardinale *et al.* 2013). Besides the biological status of the stocks, preliminary economic analysis reveals that the economic performances of EU fleets exploiting the stocks has been highly variable (Cardinale *et al.* 2013; STECF 2013). Of course major problems remain for the effective and successful management of European marine fisheries, as highlighted in the 2009 Green Paper on the reform of the Common Fisheries Policy (CFP) (COM 163 2009) and taken up in the Commission's proposal for a new CFP (COM 425 2011).

---

<sup>1</sup> We follow the definition provided by FAO:

Fisheries management authority is the legal entity which has been assigned by a State or States with a mandate to perform certain specified fisheries management functions. Fisheries management organizations or arrangements are international institutions or treaty arrangements between two or more States that are responsible for fisheries management, including the formulation of the rules that govern fishing activities. The fishery management organization, and its subsidiary bodies, may also be responsible for all ancillary services, such as the collection of information, its analysis, stock assessment, monitoring, control and surveillance, consultation with interested parties, application and/or determination of the rules of access to the fishery, and resource allocation.

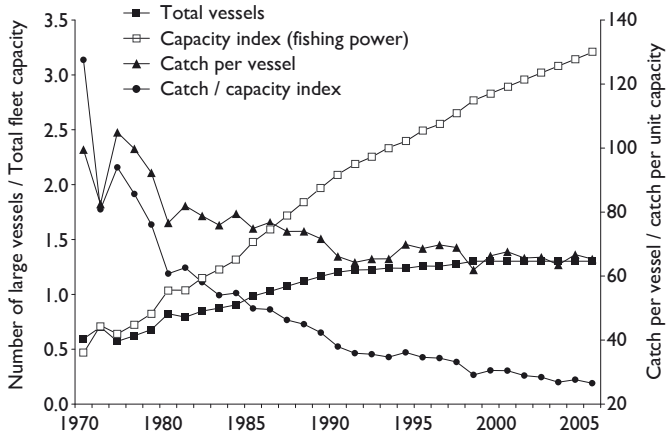

**Figure 1** The build-up of redundant fishing fleet capacity, deployment of increasingly powerful fishing technologies and increasing pollution and habitat loss has depleted fish stocks worldwide. Despite increasing fishing fleets and fishing power, the global marine catch has been stagnant for over a decade. This resulted in a declining economic health of the world's marine fisheries. Recent commitments to maintain or restore stocks to levels that can produce Maximum Sustainable Yield (MSY) have already shown great promises to achieve this goal, however much remains to be done (World Bank 2009).







# Chapter 5

## Global fisheries management

Foto: © Christian Vanden Berghe



# Chapter 5

## Global fisheries management

The solution to the ‘tragedy of the commons’ cannot be presented by the state, but rather by international (or sometimes regional) decision-making and regulations, i.e. international regimes (Joyner 1998) intended as ‘institutions’<sup>1</sup> (Young 1997) or ‘systems of governance’ (Vogler 2000a; Brans & Ferraro 2012) that regulate and manage specific issues of international relations (Gutierrez *et al.* 2011; Brans & Ferraro 2012). In the next chapter we will discuss how fisheries has become an issue of global concern and what type of international regimes have been developed. These international regimes have high implications at the European and national policy, as recognized under e.g. the reformed CFP and Marine Strategy Framework Directive (MSFD, Directive 2008/56/EC).

### 5.1 FISHERIES AS GLOBAL COMMON RESOURCES

Fisheries management is more than merely a national consideration. Marine natural resources (e.g. fish stocks) do not recognize national borders. Moreover, human activities with a large impact on the environment are not restricted to the border of a single nation. Buck (1998) defines natural resources, such as fish stocks, as materials that behold an economic and social value once they are extracted from their natural state. The spaces where these natural resources are located are called ‘resource domains’, in this case the ‘oceans of fish’ (Buck 1998). Due to the peculiar features of the resource domain, some natural resources are characterized by high subtractability and difficult exclusion. Subtractability refers to the fact that once a resource is extracted from its resource domain by one individual, it is unavailable to others (Buck 1998). In fisheries, if one fisherman lands a ton of fish, those fish are not available to other fishermen (Ostrom *et al.* 1994). The term exclusion indicates the feasibility of excluding others from using the resource (Ostrom *et al.* 1994; Buck 1998). Resources with these characteristics (high subtractability and difficult exclusion) are labelled as ‘common-pool resources’ (Hardin 1968; Ostrom *et al.* 1994; Buck 1998), fish being an example (Vogler 2000). The domains in which common-pool resources are found, i.e. the oceans, are called the ‘commons’ (Hardin 1968; Vogler 2000).

---

1 Institutions are commonly understood as systems of agreed rules that define social practices, assign roles to participants in those practices and guide their interactions (Risse *et al.* 2001)

Due to the open access that characterises their domain, common-pool resources are usually subjected to exploitation, depletion and collapse (Vogler 2000). On the basis of this consideration, the biologist Garrett Hardin (Hardin 1968) has theorized on the ‘tragedy of the commons’. Those in favour of this perspective believe that the commons can only be saved from a tragedy by an external authority, the state, either by means of state regulations or privatization (Hardin 1968; Vogler 2000; Gutierrez *et al.* 2011). This problem becomes very pronounced in fisheries, where the commons, fish, are not always localized within national territories and sometimes do not fall under any country’s jurisdiction. Hence, fisheries resources present in the Exclusive Economic Zone (EEZ) (i.e. sea area under national jurisdiction) are a local-common resource rather than a global-common resource (Vogler 2000). Nevertheless, the original concept of global commons may be expanded as part of a global biomass whose misuse negatively affects not just local or regional populations, but us all (Ferraro 2010). From this perspective the biodiversity of the entire planet can be interpreted as an ‘emerging global common’ (Flitner 1998). The common aspect of the world biomass does not lie in its location or appropriation, but on the ‘globally common effect’ that its destruction may cause (Joyner 1998). The use or abuse of these natural resources could produce profound impacts worldwide, although they are enclosed within national sovereign territories and put under national jurisdiction. These are ‘resources of global concern’ (Joyner 1998). By adaptation of this argument to fisheries, the mismanagement of fisheries resources located in the area under national jurisdiction, the Exclusive Economic Zone (EEZ), has consequences for biodiversity that do not stop at the border of the EEZ (see further). This makes the areas of national jurisdiction such as the EEZ the object of a global responsibility (Ferraro 2010). It is in this area, then, that fisheries can be properly considered as local resource of global concern. From this definition, the solution to the tragedy of global commons cannot be represented by the state, but rather by international (or sometimes regional) decision-making and regulation (Joyner 1998). Similarly, if local commons are no longer and simply of local concern, but matter for the whole international community, then a global intervention transcending the state is needed (Joyner 1998; Ferraro 2010). International regimes have grown since the end of World War II in response to the demand for governance in areas of international relevance (Breitmeier *et al.* 2006), including the management of global commons (Vogler 2000; Ferraro 2010). Therefore, fisheries are characterized by the presence of an international regime. The international legal framework governing (national) fisheries resources (intended as local commons of global concern) is presented below.

## 5.2 INTERNATIONAL FISHERIES MANAGEMENT

Numerous international treaties have targeted various aspects of fisheries and have focused on specific geographical regions or all oceans, addressed single species of fish stock or all fisheries resources, and ruled fishing activities in the high seas or the sea area under national jurisdiction. Our focus will target the EEZ fisheries. Although recent attention of the international community has focused on the problems of high seas fisheries, the deplorable state of many domestic fisheries regimes has been largely ignored (Barnes 2006). As over 90 per cent of commercial fisheries are concentrated within the EEZ, effective management within the 200 nautical miles remains fundamentally important.

The global concern for fisheries is structured by the United Nations (UN) and its agencies through binding and non-binding instruments. The agreements provide guidance for additional regional arrangements and national actions. Within the global governance for fisheries, (Turrell 2004) distinguishes three policy strands:

- One leading to the United Nations Convention on the Law of the Sea (UNCLOS 1982, 1994)
- One related to the UN Conference on Environment and Development (UNCED 1992)
- And a third one steered by FAO

With regards to global fisheries in the EEZ four agreements are of special concern:

- The United Nations Convention on the Law of the Sea (UNCLOS)
- UNCED and Agenda 21
- The code of Conduct for Responsible Fisheries
- The Johannesburg Plan of Implementation

### 5.2.1 UNCLOS

For thousands of years, the sea was simply a source of food and local transport, and was only of interest to people to that extent. With the rise of the great seafaring nations such as the Netherlands, Portugal and Spain from the 15th century onwards, these kingdoms increasingly sought to expand their influence range. Access to mineral resources and other new commodities aroused ambitions and triggered a race to conquer the oceans, faraway islands and coastlines and thus achieve global dominance.

The pivotal issue was, and is, whether the sea is international territory that all nations are free to use it, or whether it can be claimed by individual states. The principle of the 'freedom of the seas' (*mare liberum*) started to be questioned in the first half of the twentieth century by national claims on a broader area of the sea. Such claims led to the revision of international law (Vogler 2000). After three UN Conferences on the Law of the Sea (UNCLOS I in 1958, UNCLOS II in 1960 and UNCLOS III from 1973-1982), the United Nations Convention on the Law of the Sea (UNCLOS) was adopted in 1982 and entered into force in 1994 (following the 60<sup>th</sup> ratification) (Buck 1998; Krichner 2003; Boyle 2006). Until now, UNCLOS provides the primary legal instrument for governance of the seas. Under this convention, each coastal state has the exclusive rights to exploit marine resources in their Exclusive Economic Zone (EEZ), which extends to a distance of 200 nautical miles from the coastal baseline (Part V of the UNCLOS, art. 57). The EEZ does not belong to the national territory (except for the 12 nautical miles territorial limit). The coastal state has specific limited rights which apply not to the maritime area itself but only to the resources within (UNCLOS, art. 62). As the term 'Exclusive Economic Zone' implies, the coastal state has sovereign rights for the purpose of exploring and exploiting, conserving and managing the natural resources whether living or non-living, of the water superjacent to the seabed and of the seabed and its subsoil (UNCLOS, art. 61,62). These rights also apply to other activities for economic exploitation and exploration, such as the production of energy from water, currents and winds. Exploitation of resources comes with a responsibility. As such, coastal states are empowered to conserve and manage marine living resources based on the best scientific evidence available (UNCLOS, art. 61). The coastal state can determine where fisheries activities are prohibited or restricted, they determine the allowable catch of the living resources and have the duty to maintain and restore the resources through proper conservation and management measures, taking into consideration a multi-species approach and ensure that the living resources are not endangered by overexploitation (UNCLOS, art. 61). Fisheries in the EEZ by third parties are very much dependent on agreements and arrangements that give those states access to the surplus of the allowable catch. Nationals of third states fishing in the EEZ of the coastal state have to comply with the laws and regulations of the coastal state (UNCLOS, art. 62).

## 5.2.2 UNCED

Despite its intentions, the UNCLOS left coastal states with a great autonomy with respect to the management and exploitation of natural resources within their EEZ, without providing any international mechanism to prevent national irresponsible management (Barnes 2006; Ferraro 2010). Moreover, coastal states – in order to increase the effort of domestic fishing have excluded foreign vessels from their marine zones and pushed distant water states to expand their activity on offshore fish stocks (Barnes 2006; Ferraro 2010). To address these shortcomings, Agenda 21 was developed by the United Nations Conference on Environment and Development (Rio de Janeiro, 1992). Agenda 21 has developed a more sophisticated approach to the protection of the marine environment than the one contained in UNCLOS<sup>2</sup> (Boyle 2006). Chapter 17, ‘the Oceans Chapter’, represents an important reference point for fishery management and the sustainable use of marine living resources<sup>3</sup>. It pursued three primary goals:

- Conservation of biological diversity
- Sustainable use of natural resources
- Assurance that the utilization of genetic resources and information (for example, for medically useful substances) is equally beneficial for all countries

In turn Agenda 21 has influenced the elaboration of the Code of Conduct for Responsible Fisheries (CCRF) (Gjerde 2006; Maes 2008).

With the purpose of putting sustainable development in practice, the full implementation of Agenda 21 was reaffirmed by the Johannesburg Plan of Implementation, adopted at the 2002 World Summit on Sustainable Development. It establishes a set of targets and timetables (United Nations 2002). A whole section (UNCED, Chapter 4, Par.30-36) is dedicated to the protection of the marine environment (United Nations 2002) and has supplemented the framework of Agenda 21 (Chapter 17), by establishing ‘time-bound targets’ for several commitments (Ferraro 2010). Having as its overall goal the restoration of fish stocks by 2015 (JPOI Par. 31), the Plan calls for the endorsement and implementation of all instruments composing the international fisheries regime listed in this section. Nevertheless, this document is a non-binding instrument or a soft law attempting to guide decisions and actions of national governments (La Viña 2003).

---

2 17.1 ‘(...) international law, as reflected in the provisions of the United Nations Convention on the law of the Sea (...) referred to in this chapter of Agenda 21, sets forth rights and obligations of States and provides the international basis upon which to pursue the protection and sustainable development of the marine and coastal environment and its resources (...)’.

3 See Agenda 21: Chapter 17: ‘protection of the oceans, all kinds of seas, including enclosed and semi-enclosed areas, and coastal areas and the protection, rational use and development of their living resources’.

### 5.2.3 FAO

Agenda 21 (together with the 1992 Cancun Declaration) promoted the elaboration of a Code of Conduct for Responsible Fisheries (CCRF) by the Food and Agriculture Organization (FAO), adopted in 1995 (Turrell 2004). By including aspects of the UNCLOS and emphasizing the concepts of sustainable use originated from the UNCED process, this document strengthens the existing international framework for fisheries (Boyle 2006). Furthermore, the CCRF establishes a set of principles for the formulation and implementation of national responsible fisheries policies (Turrell 2004). Although some parts of the Code are based on rules of international law and other legally binding international agreements, the CCRF remains a soft-law instrument with a non-binding and voluntary nature (Maes 2008; Ferraro 2010). The CCRF aims to orientate states so they design their domestic fisheries policies in a way that sustainability can be achieved (Barnes 2006). Yet, binding effect can only be given to the Code's articles by governments' voluntary transposition into national legislation and domestic implementation (Boyle 2006).

According to Turrell (2004) and Garcia *et al.* (2003), the first strand of international ocean governance has been driven in a top-down manner, with a narrow participation of stakeholders (BOX 3 Policy cycle). Mainly governments and industrial lobbies<sup>4</sup> (De Santo 2010; Rice 2011) led this process and aimed 'to exploit and manage the living and non-living resources of the oceans within a legal framework' (Turrell 2004; Ferraro 2010). Although the UNCLOS mentions the need to protect and preserve ecosystems and habitats of depleted, threatened and endangered species<sup>5</sup>, the issue of biodiversity is absent (Turrell 2004; Boyle 2006), due to the lack of scientific knowledge on ecosystems' interactions at the time when the document was adopted. As such, UNCLOS rather reflects a traditional 'fisheries management' approach (adopted by national governments since the 1940s), which deals with each single target stock individually and separate from the surrounding ecosystem (Turrell 2004). The shift towards concerns for the ecosystem was marked in the 1992 United Nations Conference on Environment and Development (UNCED).

---

4 Although it is not our intent to describe in detail the involvement of the different stakeholders within the lobby process, we'd like to point out that there is a difference between the role of stakeholders within fisheries and ecosystem management. Both fisheries and ecosystem management are based on evolving science, the progress of the entire process is somewhat different. Whereas in fisheries management, the outcome is considered through an administrative process that shows strong inertia, reinforced by the inherent resistance to change of the sector, struggling with the direct practical, social, economic and political consequences of the change. Within ecosystem management however, the decision processes seem to operate under higher public pressure often organized by Non-Governmental Organizations (NGOs) through an efficient use of the media (Garcia *et al.* 2003). It is evolving rapidly, supported by a large number of citizens, most of them with limited or no understanding of the costs of change to the sector and who often assume a zero cost to themselves.

5 See UNCLOS art. 61, 64-67, 117-120, 194.5



Where the ecosystem is defined as ‘a dynamic complex of plant, animal and micro-organism communities and their non-living environment interacting as a functional unit’ (CBD, art. 2). The main documents produced at the UNCED–Agenda 21 and the Convention on Biological Diversity (CBD) represent an international acknowledgement of the concept of ‘ecosystem management’, which already appeared in scientific debate since the 1970s. The ecosystem management indicates a philosophy that bridges ecological, economic and social information and concerns for a sustainable use of ecosystems in order to guarantee resource continuity (Garcia *et al.* 2003).

On the wave of this shift towards ecosystem considerations (instead of single species), the many principles contained in the CCRF have been embodied in the comprehensive concept of ‘ecosystem approach to fisheries Management’ (EAFM), in the early 2000s. Introduced by FAO and defined by the 2001 Reykjavik Declaration, the EAFM indicates a framework for fisheries governance that takes ecosystem considerations into more conventional fisheries management (Garcia *et al.* 2003) and bridges economic, biological, and social considerations (Rice *et al.* 2010). It is an ‘ecosystem-based fisheries management’<sup>6</sup>, where ecosystem includes biotic, abiotic and human components (Jennings & Rice 2011; Rice 2011).

### 5.3 EUROPEAN MARITIME POLICY

As a result of international agreements developed by the United Nations, the Ecosystem Approach to Management is now broadly accepted as a key management principle (Turrell 2004; Bianchi & Skjoldal 2008; Rice *et al.* 2010). In 2002, the European Union committed to the Johannesburg Plan of Implementation, which states that stocks should be recovered to levels that can produce maximum sustainable yields (MSY) where possible by 2015. MSY is generally defined as the maximum use that a renewable resource can sustain without impairing its renewability through natural growth and replenishment (Cardinale *et al.* 2013). In 2006 this led to the Green Paper on a Future Maritime Policy for the European Union (COM 275 2006). The Green Paper examined all economic activities of Europe which are linked to, or impact upon, the oceans and seas, as well as all the policies dealing with them, with a view to finding the best way to extract benefit from the oceans in a sustainable manner. This commitment represents the first pillar on which the European Commission (EC) considers its new Marine Policy.

---

<sup>6</sup> In EAFM, existing sectoral fisheries management institutions generally maintain their identities, but have their mandates and accountabilities extended. On the other hand Ecosystem-Based Management starts by identifying the spatial delineation of ecosystems and its key properties as the basis for management (Ferraro 2010)

In October 2007 the EC presented its vision for an Integrated Maritime Policy (IMP, also known as the ‘Blue Book’). The IMP lays the foundation for an overarching maritime policy, encompassing all sectors and aiming to provide a stable and dynamic policy framework to secure growth, jobs and environmental sustainability on a long-term basis (COM 575 2007; Rice *et al.* 2010). Following an extensive consultation, the European Parliament and Council adopted in 2008 a new Marine Strategy Framework Directive (MSFD, Directive 2008/56/EC), which intends to be the environmental pillar of the IMP and can be seen as the legal and practical implementation of the Ecosystem Approach to Management (EAM). In line with these regional and European-wide developments, individual sectors are also modifying policies to make sectoral management coherent and compatible with the MSFD (BOX 1 IMP and MSFD). As part of a plan to reform the Common Fisheries Policy (CFP), the European Union’s instrument for the management of fisheries and aquaculture, the EC launched a review in 2008<sup>7</sup> to make the CFP more efficient and more integrated with the Maritime Policy (COM 163 2009; De Santo 2010). The overarching aim of the reformed policy is to end overfishing and make fishing sustainable. Some of the key elements of the policy entails the banning of discards, moving towards multi-annual planning, implementing MSY and eliminating illegal, unregulated and unreported fishing. More details on the reform of the CFP are presented below (see Chapter 6)

---

<sup>7</sup> It should be noted that one of the reasons why the CFP is currently under reform is a result of the legal requirement that the CFP (as every European Common Policy), has to be reviewed at regular 10 year intervals and the last reform was conducted in 2002.

**BOX 1 - Integrated Maritime Policy and the Marine Strategy Framework Directive**

As of 2007, the EU has delivered important policy instruments to support the sustainable use, management and protection of its marine waters. An important step was the establishment of the Integrated Maritime Policy (IMP) which aims towards a more coherent approach to manage maritime activities across a range of sectors and policy areas to achieve full economic potential. Some of the cross-cutting objectives included in the IMP are: marine data and knowledge, Maritime Spatial Planning (MSP), Blue Growth, regional coordination and integrated maritime surveillance. Central to all the above policies is the achievement of a sound scientific and practical basis for the implementation of an EAM. From a purely fisheries perspective, EAM requires implementation of the Maximum Sustainable Yield (MSY) concept, which emerged from the 2002 World Summit on Sustainable Development in Johannesburg. Exploitation levels should aim at restoring and maintaining fish and shellfish resources at levels which can produce the MSY no later than 2015 where possible (EC SEC, 2011/891 & 892 final). The environmental pillar of the IMP, the Marine Strategy Framework Directive, entered into force in June 2008. This directive requires that Member States with marine territories put in place appropriate targets and measures towards achieving good environmental status (GES) by 2020, according to eleven key descriptors. The MSFD is a far reaching commitment for EU Member States to assess, monitor and improve the environmental quality status of Europe's marine waters. Additionally, the MSFD has fundamental implications for fisheries and other maritime human activities. The state of commercially exploited fish and shellfish stocks is directly addressed within the MSFD by GES descriptor 3: population of commercial fish/shellfish, but is also a central component in GES descriptor 1: biological diversity and 4: marine food webs. Moreover, fisheries are major driver of relevance to descriptor 5: eutrophication and 6: seafloor integrity and hence of central importance to achieve GES. Additionally, the MSFD has fundamental implications for fisheries and other maritime human activities. The state of commercially exploited fish and shellfish stocks is directly addressed within the MSFD by GES descriptor 3: population of commercial fish/shellfish, but is also a central component in GES descriptor 1: biological diversity and 4: marine food webs. Moreover, fisheries are major driver of relevance to descriptor 5: eutrophication and 6: seafloor integrity and hence of central importance to achieve GES.

However, it is widely accepted that there are significant knowledge gaps which may hinder the full implementation of the MSFD. Coordinated marine research targets to address these gaps will be essential to underpin the stated objectives of achieving GES in European water by 2020. At the European level, the 7th Framework Programme (FP7, 2007-2013) has played an important role in promoting pan-European collaborative research in marine science and technology, reducing the fragmentation of available research capabilities (human and infrastructure capital) and supporting the coordination of research activities, strategies and programmes (Howlett *et al.* 2009). Among many other initiatives, FP7 saw the introduction of the Ocean of Tomorrow 2012 coordinated calls which focused largely on addressing the knowledge gaps concerning implementation of the MSFD. The EU FP7 STAGES9 project is addressing the structural aspects of transferring knowledge from science to inform policy and decision making in support of MSFD (European Marine Board 2013). As of 2014, the marine research community is now turning its attention to the next European Framework Program, Horizon 2020. This legislative act will run from 2014 to 2020, anticipating a strengthening of support for marine and maritime research, building on the success of previous programs. This program focuses on societal challenges, which will require a much greater involvement of industry partners from various sectors to help bridge the gap between research and the market. Horizon 2020 will include measures aimed at further developing the European Research Area (ERA), which aims to unite national funding agencies to create a single European market for knowledge, research and innovation. Another initiative by EC Marine Knowledge 2020 aims to make marine data available from different sources for use by industry, public authorities and researchers. This reflects the shift in perspective that data should not necessarily be collected for a single specific purpose, but should be used many times and by several users. At the core of the strategy is the European Marine Observation and Data Network (EMODnet), a single entry point for accessing and retrieving marine data derived from observations, surveys or samples from the hundreds of databases maintained on behalf of agencies, public authorities, research institutions and universities throughout the EU. Additionally, a joint data network may accomplish Member States to share protocols for data collection and handling. Minimizing the need for data harmonization and increasing the accuracy of every data set as all practitioners would be familiar with the protocol.

### 5.3.1 The Common Fisheries Policy

The primary policy instrument for fisheries and aquaculture management in the European Union is the Common Fisheries Policy (CFP), presently under revision (see Chapter 6). The supranational aspect of fisheries in Europe grew out of its long standing fishing traditions. At the time UNCLOS implemented a 200 nm fishery conservation zone, Europe's fisheries were already highly international, with many fleets fishing a long distance from the home port. To avoid conflicts that the new EEZ regime might have caused, the emerging European institutions brokered a deal which granted Member States free mutual access to each other's waters. This way each nation's traditional fishing grounds and practices could be preserved. This happened in the early 1970s, when fisheries were part of the European Common Agricultural Policy (CAP). The first regulation for the markets of fishery and aquaculture products also dates from the early seventies. The main instrument to manage the conservation of fisheries (and aquaculture) in the European Community, known as the Common Fisheries Policy (CFP), was created in 1983 after many years of consultation and negotiation (European Commission 2009; Rice *et al.* 2010). Under this system, Total Allowable Catches<sup>8</sup> (TACs) for each fish stock are shared between Member States of the EU.

The CFP is one of the few areas where the EU has the exclusive competence in all decision<sup>9</sup> (European Union 2012). In total three institutions are involved in fisheries policy making. The first institution is the European Council of Fisheries Ministers (further in the text referred to as the Council). Before the Lisbon Treaty, enacted as of December 2009, they made all final decisions concerning the exploitation of EU fisheries resources. Only elected representatives of each Member State, the Ministers, are granted a seat in the Council. The Councils are prepared almost weekly in the working group on internal and external fisheries policy. The proposals which the Council has to decide upon, however, come from the EC through its executive body: the Directorate-General for Maritime Affairs and Fisheries (DG MARE). The EC is granted the exclusive initiative right to propose new regulations.

---

8 The CFP sets quotas for how much of each commercial species can be caught in a certain area. The TACs are shared between EU countries under a system known as 'relative stability' which keeps national quotas stable in relation to each other, even when the total quantity of fish that can be caught varies with the productivity of the stocks.

9 There is a fundamental bifurcation between fisheries management and nature conservation in Europe, which has its roots in the European Lisbon Treaty (Rice 2011). While the European Commission retains the exclusive competence over fisheries, Member States are responsible for nature conservation throughout their EEZs. This difference is also visible in the legislations, while DG MARE produces regulations that are immediately enforceable by Member States, measures emanating from the Directorate General for the Environment are typically directives. Member States have to come up with their own national legislations in order to enact these directives. A process which causes quite some delay (see BOX 2 Lisbon Treaty, De Santo 2010).

To elaborate these new regulations the EC consults all stakeholders and for scientific advice they mainly appeal to an existing expert panel (e.g. STECF, see below) or create a new one, depending on the needs of the new legislations. The experts in these panels do not represent the Member States, but provide a personal expert opinion to the EC. Based on the output given by the experts and different stakeholders, the Commission sets up the proposals for new legislations, such as the proposal for a new regulation on the CFP in 2011 (Figure 1, COM 425 2011).

The Lisbon Treaty, enacted as of December 2009, increased the involvement of the European Parliament (EP) in the legislative process, through the co-decision procedure (TFEU, art. 294). This procedure means that, besides the power of the Council, a co-decision by the EP is needed<sup>10</sup> (BOX 2 Lisbon Treaty), whereas so far the role of the EP within the fisheries decision making process had been advisory and rather unclear (Wilson 2009). With the major reform proposed by the EC (see Chapter 6), the fisheries policy is now a very high profile issue on the general agenda of the EP. Only after the Council and the EP have agreed internally on their common position in relation to a proposal from the EC, the negotiations between EC, Council and EP can start. Before the EP votes in plenary, each regulation<sup>11</sup> is prepared by the Parliament Commission for Fisheries (PECH committee). The EP is made up of many nationalities with different interests, which must be responsive to media, political, and industry pressures. The diverse political groups and intricate internal decision-making processes, makes the EP not a completely cohesive unit. However, in light of the upcoming Council negotiations, the EP has to reconcile these conflicting interests and reach a consensus. Otherwise, the Council will gain the upper hand, already having a majority of Member States backing its position, whereas the Parliament will not have had as much time to gather support outside of its specialized committees (Saarinen & Monar 2012). During the course of decision-making, both the Council and the EP are approached by many actors, including the civil society, consumer groups and non-governmental organisations (NGOs) (Daw & Gray 2005). Fisheries representatives are not as well organised at the EU level as NGOs, and prefer to exert pressure domestically. Their interests are then mainly represented in the Council<sup>12</sup>. This development will obviously bring forth benefits in terms of representation and democratic legitimacy, but it will not be without certain challenges either. Nevertheless, due to the co-decision power, the risk of representing only a few interest groups will be avoided ([www.clientearth.org](http://www.clientearth.org)).

---

10 This procedure provides the EP the power to adopt instruments jointly with the Council of the European Union, i.e. it becomes co-legislator, on a level with the Council.

11 Fisheries policy involves three regulations, the basic regulations, financial regulation and market regulation. In case of the basic regulation Ulrike Rodust is rapporteur

12 <http://ocean2012.eu/?lang=en#>, [www.seas-at-risk.org](http://www.seas-at-risk.org)

Within the context of setting the fishing possibilities (TACs and fishing effort) the Council has to decide upon the regulations on a yearly basis. The TACs are set for each stock (species per area) and are divided amongst Member States as quotas (see 7.2). The allocation of the quota is based on fixed allocation keys (called 'relative stability'), which are related to the proportion of the catch which Member States enjoyed before joining the CFP. The quotas are non-negotiable and provide fishers with an environment which is relatively stable (Holm 2004; European Commission 2009). All recommendations made by the EC are based on scientific advice delivered from its own Scientific, Technical and Economic Committee for fisheries (STECF) (Figure 1, European Communities 2002; European Commission 2005).

STECF produces annual reports on the current status of marine resources and their future potential, which is used as the basis for TAC and quota setting, effort- and technical regulations as well as management plan adaptations and developments. Their main objectives are:

- To improve the quality of policy decisions and to speed up the decision-making process
- To provide rapid response mechanisms to urgent political needs
- To promote the participation of researchers in the policy arena

Therefore the STECF plays a leading role in helping the Commission to formulate policies ranging from long-term plans to emergency closures, by providing a highly targeted scientific opinion which goes well beyond the purely biological dimension and can be made available at short notice. To support a better management, extensive economic and social advice has to be included to fully assess the impact of policy proposals. To deliver this extensive advice, the STECF relies on advice from different international advisory bodies or Regional Fisheries Management Organisations (RFMO), e.g. the International Council for the Exploitation of the Sea (ICES), the Northwest Atlantic Fisheries Organisation (NAFO), the General Fisheries Commission for the Mediterranean (GFCM), the Committee for the Conservation of Antarctic Marine Living resources (CCAMLR), the International Commission for Conservation of Atlantic Tuna (ICCAT), and so on (Figure 1). The members of this Committee are nominated by the Commission from highly qualified personnel in the scientific, technological and economic fields. However, in case of biological scientists and gear technologists, the members of STECF are often members of ICES expert groups. Although it may appear that STECF could not be seen as a completely independent body of the ICES system, it does provide a second opinion on the ICES advice, and sometimes gives a negative judgment on either the analysis proposed by ICES, or the conclusions drawn from them.

For the Northeast Atlantic Ocean, the North Sea and The Baltic Sea, scientific advice is mainly derived from ICES, (Figure 1), an international institution which brings together more than 1600 marine scientists from 20 nations, each dedicated to a specific research topic. ICES proposes long-term management plans<sup>13</sup> and for the first time in 2012 a mixed fisheries advice within the objective for a sustainable fisheries. However, one of the core tasks of ICES is assessing the status of commercially exploited fish and shellfish stocks. The models ICES applies require large amounts of data. To organize this collection, management and use of data, the CFP has set aside funding to help national authorities collect both economic and biological data about all aspect of fisheries management and make them publically available (Figure 1).

The current Data Collection Framework (DCF) was established in 2008 (European Communities 2008a) and runs until 2013. Biological data includes both fisheries dependent data, like landings, effort, discard rates, as well as fisheries independent data, such as time series of abundance and biomass collected on research vessels that consistently fish a fixed grid of sampling stations that cover the entire stock areas and/or management units (Figure 1). A combination of both data sources is required in order to see the bigger picture. However while it is precisely this knowledge allowing fishers to maximize their yield, fisher-dependent data (catch, landing etc.) tends to be biased and lead to overestimations of the absolute abundances of fish. Where fishermen understandably change their spatial behaviour according to the constantly changing distribution of fish aggregations, fisheries independent data aim to estimate the overall abundances of marine live in a fixed grid.

In parallel with the development of the new CFP and the European Maritime and Fisheries Fund (EMFF), the Commission has proposed for a new Multi-Annual Program for data collection (DCMAP) for the period 2014-2020. Articles 37 and 38 of the CFP reform set out the broad obligation for Member States to collect biological, technical, environmental and socio-economic data and to cooperate regionally. The EMFF will serve as the financial pillar of the future data collection program, providing the basis for national programs implementing the DCMAP (STECF 2012).

---

13 Within the proposal of the Commission on the CFP it is stated that multi-annual plans should where possible cover multiple stocks where those stocks are jointly exploited. The multi-annual plans should establish the basis for fixing fishing opportunities and quantifiable targets for the sustainable exploitation of stocks and marine ecosystems concerned, defining clear timeframes and safeguard mechanisms for unforeseen developments. One approach to making TACs more effective as a management measure in mixed fisheries such as those of the North Sea would be to account for the technical interactions that arise when multiple fleets use different gears to target different combinations of target species in the same area and to incorporate these effects into scientific advice on fisheries management (De Santo 2010).



Ultimately, the ICES and/or STECF advice is systematically shared with the Regional Advisory Councils (RACs)<sup>14</sup> and the Advisory Committee on Fisheries and Aquaculture (ACFA)<sup>15</sup> for them to discuss and comment on. The role of the RAC will most likely also be key to a successful reform of the CFP as they represent the organisations of the different stakeholders (see 6.3). The fishing industry finds the incremental measures and the 'one-size-fits all' approach taken by fisheries policy frustrating (Falkner *et al.* 2004; Grisel 2012). As such, RACs took a leading role in addressing problems with stock assessments as a result of limited data (ICES 2011a, b). The North West Waters RAC, for example, has appointed data coordinators to liaise with ICES scientists on specific data-limited stocks and particular data deficiencies. Better data means improved assessments and less reliance on precautionary quotas (quotas set with very little data availability and therefore a limited scientific foundation). Additionally, motivated by the involvement of the fishermen and the request of the EC to have advice on all stocks, scientists linked to ICES have further looked into methodologies for data-limited stocks (ICES 2012a). As such, since 2012-2013, ICES has developed different ways of approaching an assessment and have tried to apply models in accordance with type and abundance of data availability.

Although these methodologies might still need further refinements, ICES has successfully developed reliable methods to provide quantitative advice for most of the stocks in 2012 for the coming year of 2013 (see 7.2). This progress can be seen as a major development, as all parties (the fishing industry, scientists and managers) may benefit from fixing 'broken' assessments or establishing a method for species without any analytical assessment. A summary is depicted in Figure 1 were the flow of data collection gathered during on-board sampling, market sampling and surveys, until recommendations by the EC are passed on to the Council and EP.

---

14 To ensure that all parties are involved in the decision-making process, stakeholders have organized themselves in Regional Advisory Councils (RACs). These Councils consist of representatives of the different fishing industry sectors, but also includes other interest groups, such as environmental organizations, consumers, recreational fishers and aquaculture producers. Scientists are often invited as external experts. These RACs are organized geographically and/or by fishery. In Europe there are seven of them: five covering the different maritime areas which surround Europe, one for the pelagic sector, whose boats range widely, and one for the long-distance fleet which fishes outside European waters.

15 The other group, the Advisory Committee on Fisheries and Aquaculture (ACFA), is similar in purpose to the RACs. However, they operate at a European level representing mainly cross-European groups of the main branches of the industry from production sector, processing industry and trade in both fisheries and aquaculture as well as consumer groups and organization dealing with environmental protection and development. ACFA operates through four working groups, which deal with fisheries resources and management, aquaculture, markets and trade policy and general questions including economics and the condition of the sector.

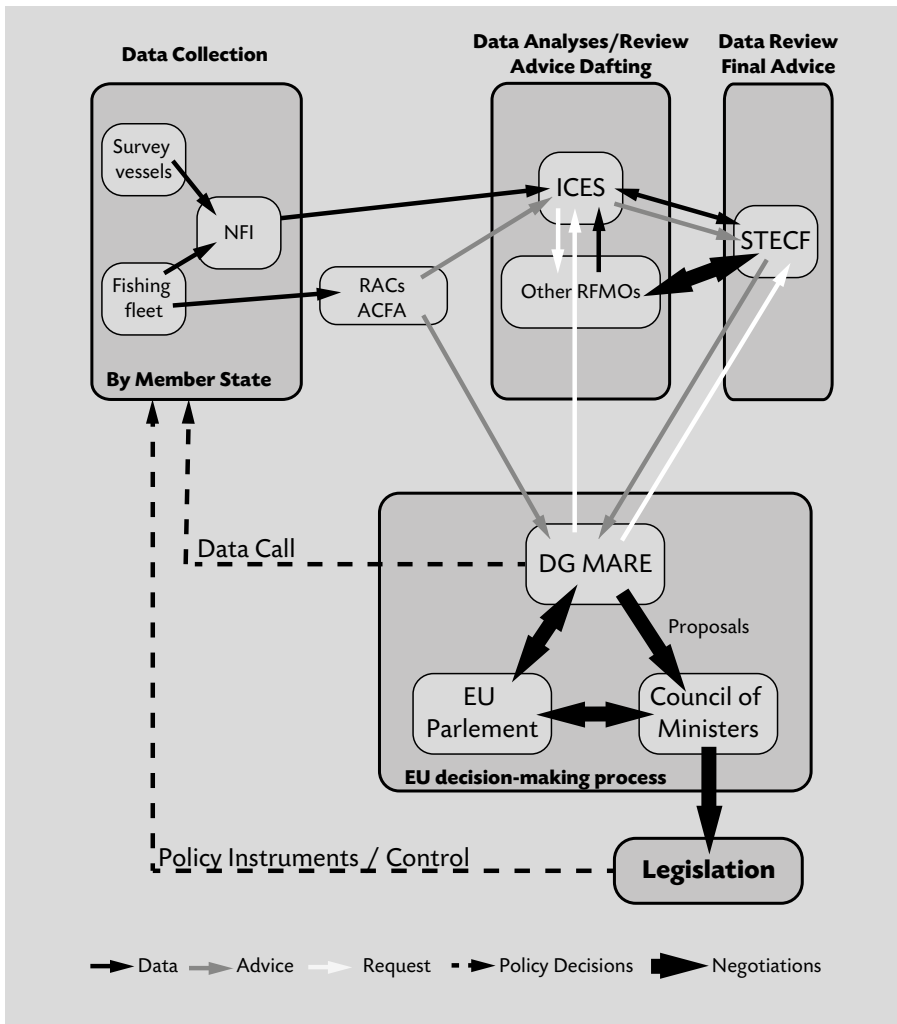

**Figure 1** From data to European regulations in the framework of the EU Common Fisheries Policy (modified from Wilson 2009). In short, Member States are obliged to gather fisheries (in)dependent data by their National Fisheries Institutes (NFI). The advice systems then moves up to the European level as the NFI supply their researchers to the ICES expert groups who, after several review rounds, draft proposals on the amount of fish that might be caught in the coming year. This is one of the main tasks of ICES, commissioned by DG MARE. The decision-making process itself consists of several steps. Whereas STECF reviews the scientific data from ICES, they also add economic and technical data. Furthermore, political and social advice from stakeholders organization like the RACs and ACFA is considered by DG MARE. Final proposals on fisheries regulations are presented to the Council and the European Parliament. They have to adapt the proposals by DG MARE and have to come to an agreement to make next year legislations. The Commission and Member States are charged with the task to implement them. Within the reform of the CFP, the EC proposes to expand the role of the RACs (more detail see 6.3).

**BOX 2 - Co-decision under the Lisbon Treaty**

The EU consists of 27 Member States. Although all are sovereign, independent countries, they have pooled some of their 'sovereignty' in other institutions to gain strength and the benefits of scale. In practice this means, that the Member States delegate some of their decision-making powers to the shared institutions they have created. The legal rules for the EU institutions, how the decisions are made and the relationship between the EU and its Member States is laid down in treaties. These treaties are negotiated and agreed upon by all the EU Member States and then ratified by their parliaments or by referendum. The last amending treaty: The Treaty of Lisbon or Lisbon Treaty was signed in Lisbon on December 13<sup>th</sup> 2007, and entered into force on the first of December 2009. Earlier treaties are now incorporated into the current consolidated version, which comprises the Treaty on European Union and the Treaty on the Functioning of the European Union (European Marine Board 2013).

The Lisbon Treaty attributes to the European Parliament new law making powers, as it is now involved in a majority of EU legislation under the procedure for co-decision with the Council of Ministers. In other words the Lisbon Treaty places Parliament on an equal footing with the Council of Ministers in decision-making. Related to fisheries, the TFEU explicitly mentions a Common Fisheries Policy (CFP) in art. 38 and a legal base is established for the CFP in TFEU, art. 43 (2 and 3). The latter two articles are highly relevant regarding issues on the exclusive and shared competence and surrounding the choice of legal base. More specifically, measures subject to TFEU, art. 43(2) will fall under the ordinary legislative procedure (formerly the co-decision procedure), where the EP and the Council are fully involved, after consulting the Economic and Social Committee. In this way the common organization of agricultural markets (which includes fisheries under TFEU, art. 38(1) shall be established together with the other provisions necessary for the pursuit of the objectives of the common agricultural policy and the common fisheries policy' (TFEU, European Commission 2012). On the other hand, measures under TFEU, art. 43(3) will be subject to a 'special' legislative procedure, which excludes the involvement of the European Parliament. The Council, on a proposal from the Commission, shall adopt measures on the fixing and allocation of fishing opportunities (i.e. setting of the annual TACs and fishing effort) and in relation to pricing (e.g. yearly setting of guide prices for the market regulation), levies, public aid and quantitative limitations. However, it should be noted that according to TFEU, art. 293, which applies to TFEU, art. 43(3), a qualified majority voting is needed to pass proposals by the Commission in Council and the Council will only be able to revise such proposals by unanimity.

Clearly, because of the different legislative procedures, the question as to what exactly falls within the process of 'fixing and allocating fishing opportunities' will become extremely important from a political point of view. TACs and fishing effort (days at sea-restrictions) clearly fall within this definition, as they aim to define the amount of fish which is allowed to be caught. However, uncertainty arises by the discrepancies of TFEU, art. 43(2) and TFEU art. 43(3), in relation the establishment of multi-annual plans. Such multi-annual plans contain so-called 'harvest control rules', which determine the annual setting of TAC's and maximum allowable effort. This discrepancy has been blocking negotiations with a proposal of the EC on the establishment of a long-term plan for cod and the fisheries exploiting them. Apart from 'harvest control rules', the cod plan contains other measures for the conservation of cod stocks. While a resource subjected to TFEU, art. 43(2) was accepted for most of its provisions, a discussion arose as to whether the proposed amendments and additions should instead be based on TFEU, art. 43(3), leaving the EP out of the decision-making process. As a result, the EP voted to postpone any new report by the EC, in order to put political pressure on the Council. By continuing to refuse to acknowledge the additional powers of the European Parliament under the Lisbon Treaty, the Council risks to block any progress on negotiating new regulations and derailing the CFP reform completely by leaving the European Parliament with no other choice but to delay the adoption of future CFP reports (European Union 2008). However, during the writing of this text, the trilogies between EP, EC and Council have come to an agreement on the basic regulations of the reformed CFP on May 30<sup>th</sup> 2013 (Gallagher 2013).

## 5.4 BELGIAN FISHERIES POLICY

The historical account of fisheries management and policy above shows that fish stocks, being a common-pool good, need to be managed on either a supranational level or, in the case of the European Union, on a regional level. This means that new rules are first defined in EU policies<sup>16</sup> (EU policy development) and then incorporated into domestic policies (domestic assimilation) (De Santo 2010; Rice *et al.* 2010).

---

16 The aims set out in the EU treaties are achieved by several types of legal act. Some are binding, others are not. Some apply to all EU countries, other to just a few. Regulations are the most direct form of EU law - as soon as they are passed, they have binding legal force throughout every Member State, on a par with national laws. They are different from directives, which are addressed to national authorities, who must then take action to make them part of national law, and decisions, which apply in specific cases only, involving particular authorities or individuals. A decision is binding on those to whom it is addressed (e.g. an EU country or an individual company) and it directly applicable. Both recommendations and opinions are non-binding and aim to suggest a line of action without imposing any legal obligations on those to whom it is addressed. Regulations are passed either jointly by the EU Council and European Parliament, and by the Commission alone.

However, international agreements and European policies can affect national policies only if states are willing and capable of incorporating these obligations into their national legislations (enactment) and ensuring their application (or execution) and enforcement (Bernstein & Cashore 2000; Brans & Ferraro 2012). It is through the enactment, execution and enforcement by the Member States that the actors' behaviour can be best steered (Ferraro 2010). Additionally, Member States are represented in the Council, which is the principal decision-makers. Consequently it is here, at the Member State level, that the problem of overfishing has to be addressed (Gutierrez *et al.* 2011; Brans & Ferraro 2012).

EU regulations, by definition, must be translated into national regulations, as they have binding legal force throughout every Member State, on par with the national laws. Whenever a Member State refuses to incorporate EU legislation, they would be punished through a monitoring and sanctioning mechanism that involves the Commission and the European Court of Justice (more detail see Falkner *et al.* 2004). In contrast, Member States are given some freedom to adapt EU Directives into national policy in line with their own economic choices, social priorities and cultural traditions, resulting in a slightly different domestic adaptation of the EU legislation (Héritier 2001; Ferraro 2010).

Given that Belgium is an EU Member State, its fisheries policy is based on the CFP. Belgian intergovernmental policies are policies that necessitate the cooperation between the federal governmental level, and regional governments. Given their central location and access to abundant organisational resources, the minister and bureaucrats in charge of a policy sector are usually the key governmental actors in the policy process, with the legislators playing a secondary role. Their societal counterparts are mainly drawn from research organisations, interests groups, business and labour. They usually bring expertise, information and interest on the issue at hand and seek influence over the policy outcomes through their subsystems<sup>17</sup> membership and participation in the policy process. The media often play an intermediating role in publicizing issues connected to the subsystem and identifying possible solutions to those issues (Howlett & Ramesh 1998; Howlett *et al.* 2009).

---

<sup>17</sup> Policy subsystem is a general term for those stakeholders which have technical knowledge pertaining to the topic (Ulrich *et al.* 2011). In the case of the fisheries sector, the policy subsystem consists of interest groups such as Flemish fish auctions, the Maritime Institute, the 'Rederscentrale' and the Stichting voor Duurzame Visserijontwikkeling vzw (SDVO), but also environmental NGOs like 'Bond beter leefmilieu' and 'Natuurpunt'. It is notable that the exact constitution of the actors involved at this stage is dependent upon which actors are traditionally recognised as stakeholders.

In the following sections we highlight the different subsystems and actors who are involved in policy-making. This process of policy-making was analysed by (Howlett *et al.* 2009) who suggested five distinct phases (BOX 1 Policy cycle). This model is useful as it separates the process of policy creating in distinct tasks, but also because it helps to clarify the different roles played by policy actors, institutions and ideas in the process, even though interactions take place (Howlett *et al.* 2009). Furthermore, once policy subsystem paradigms are connected to the appropriate stages of the policy cycle, it is possible to uncover how policy issues get on the agenda, how choices for addressing those issues are selected, how decisions on pursuing courses of action are taken, how efforts to implement the policy are organized and managed, and how assessments of what is working and what is not are produced and fed back into subsequent rounds or cycles of policy-making (Howlett *et al.* 2009). However, at the same time the validity of the stage model has been questioned during the last decade (Hill & Hupe 2009; Ferraro 2010). Although the logic of problem-solving at these specific stages might be elegant in principle, in practice the stages are often compressed or skipped, or are followed in an order unlike that specified by the model (Howlett *et al.* 2009). For example, the distinction between policy implementation and formulation might in practice be difficult. The result of past implementation decisions may have a major impact on future policy formulation, regardless of the specificities of the agenda-setting process. Nevertheless, the stage model has an analytical nature which is useful to capture the complexity of policy making in an otherwise seamless web of policy transactions (Ferraro 2010). Therefore, we want to emphasise that one should bear in mind that a specific stage is embedded in the whole system.

In Belgium, most environmental competences lie with the federal and regional governments. Together they have to implement international agreements for which they are responsible. As such, they are closely involved with the preparation of the Belgian position regarding international policy. The marine environment policy is included in the Federal Public Service (FPS) of Health, Food Chain Safety and Environment, which comprises four Directorate-General (DG)<sup>18</sup>. Marine Environment is enclosed in the DG Environment, which is the contact agency for European and international agencies, as they impose new legislations which have to be adapted into national policies<sup>19</sup>. However, under the Federal structure of the Belgian state, responsibility for marine fisheries has been transferred to the Flemish regional government. As of April 1st 2006, this government is organized into 13 Policy Areas, from which the Agriculture and Fisheries Policy Area is of concern here.

---

18 The four DGs are: Health Care Facilities Organisation (DG1), Primary Health Care and Crisis Management (DG2), Animals, Plants and Food stuffs (DG3) and Environment (DG4).

19 [http://www.health.fgov.be/eportal/Environment/MarineEnvironment/9484500?ie2Term=policy.&ie2section=9128&fodnlang=n#\\_UYThsUp6Li4](http://www.health.fgov.be/eportal/Environment/MarineEnvironment/9484500?ie2Term=policy.&ie2section=9128&fodnlang=n#_UYThsUp6Li4)

Each Policy Area contains a few fixed elements (Figure 2):

- The Minister who determines the policy, who regulates the enactment, evaluate progress and adjusts policy when and where needed.
- The Strategic Advisory Council plays a key role in the policy formulation process. In contrast to the other entities of the Ministry, the advice organs work independently, which means they have their own personal, endowment and legal independence, they serve as an independent actor which assures the objectivity of the advice and entitles them to give advice on a bill on their own initiative. This advice concerns all economic, ecological and social aspects of agro-horticulture and fisheries. The Strategic Advisory Board on Agriculture and Fisheries (SALV)<sup>20</sup> represents the different stakeholders e.g. the unions, Flemish auction halls, the Maritime Institute, the Fishermen Union 'Redercentrale'<sup>21</sup>, 'The Foundation for Sustainable Fishery Development (SDVO), environmental NGOs, and so on. A direct participation of scientists, however, is lacking. Several times a year all stakeholders comment in a meeting on a 'Policy Note' prepared by the Ministry. By organizing these meetings, the Policy Area receives formally advice from all stakeholders through the announcement of a publically available report. Furthermore, from a stakeholders' point of view, the SALV reassurances them that whenever a bill is drafted by the Policy Area, they will be notified through these meetings.
- The Policy Council includes the Minister, his head of the Ministers Office and all managers of the different entities comprising the Agriculture and Fisheries Policy Area. In this Policy Area the political and administrative arena consults with one another. The different entities of the Agriculture and Fisheries Policy Area comprises of three Internal Autonomous Agencies (IVA) encompassing: the Department of Agriculture and Fisheries<sup>22</sup>, the Agency for Agriculture and Fisheries<sup>22</sup> (ALV) and the Institute for Agricultural and Fisheries Research<sup>23</sup> (ILVO). Furthermore, this Policy Area consist of one External Autonomous Agency (EVA). The Flanders' Agricultural Marketing Board<sup>24</sup> is a non-profit organization promoting the sale, the added value, the consumption and the image of products and services of the Flemish agriculture, horticulture, fishery and agro-alimentary sector in Belgium and abroad.

---

20 For more detail we advise to visit the website: <http://www.salv.be>

21 The Redercentrale is a producers organization which is also represented in the RACs and the European Association of Fish Producers Organizations (EAPO)

22 More information can be found on <http://lv.vlaanderen.be>

23 More information can be found on <http://www.ilvo.vlaanderen.be/>

24 More detail at <http://www.vlam.be/>

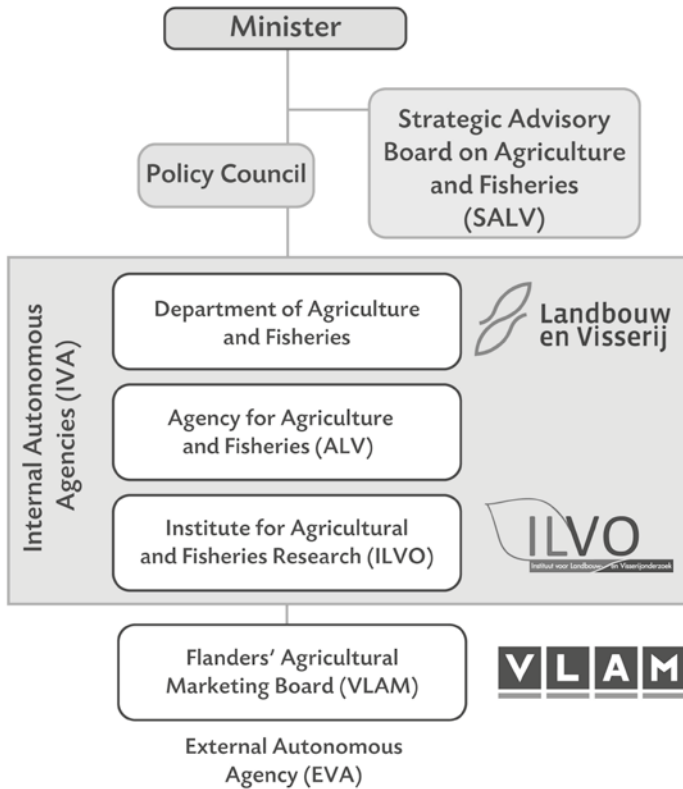

**Figure 2 Agriculture and Fisheries Policy Area of the Belgian Member State. The responsibility for marine fisheries has been transferred to the Flemish regional government. Within this government, the Policy area comprises four entities which assist the Minister: the Department of Agriculture and Fisheries, the Agency for Agriculture and Fisheries, and the Institute for Agricultural and Fisheries Research (ILVO). Furthermore, this Policy Area includes one external independent entity: the VLAM. The Strategic Advisory Council (SALV) is an independent actor entitled to provide the Policy Area with advice concerning new policies.**

The Department of Agriculture and Fisheries is qualified to shape proposals and designs about market and income policy for the Flemish agricultural, horticultural and fisheries sector. Being part of the European Union, they are authorized to translate International and European policy into national legislations<sup>25</sup>. They accomplish this task by regularly consulting other relevant services, producer organizations and other stakeholders.

<sup>25</sup> The aims set out in the EU treaties are achieved by several types of legal act. Some are binding, others are not. Some apply to all EU countries, other to just a few. A regulation is a binding legislative act. It must be applied in its entirety across the EU. A directive is a legislative act that sets out a goal that all EU countries must achieve. However, it is up to the individual countries to decide how. A decision is binding on those to whom it is addressed (e.g. an EU country or an individual company) and it directly applicable. Both recommendations and opinions are non-binding and aim to suggest a line of action without imposing any legal obligations on those to whom it is addressed.



Within the Agriculture and Fisheries Policy Area, the Department has a much broader purpose as they are not only entitled to translate the European policy, formulate policy proposals and design new regulations, but they also acts as the executive organ of the Belgian fisheries policy through their Sea Fisheries Office in Ostend. This office is responsible for the coordination, execution of the fisheries data collection (e.g. amount of landed fish in Belgian ports or by Belgian vessels) and enforcement of the fisheries policy. Usually, the enforcement of a policy involves the Agency for Agriculture and Fisheries, such as the control of all innings and payments of subsidies and levies of European funds. However, for fisheries these tasks are also accomplished by the Sea Fisheries Office. Financial support for fisheries is driven by the European Fisheries Fund (EFF) and the Financial Instrument for the Flemish Fishing and Aquaculture Industry (FIVA) until the end of 2013.

The third and last IVA of the Ministry of Agriculture and Fisheries, is the Institute for Agriculture and Fisheries Research (ILVO). This is a multidisciplinary scientific institute which conducts research in agro- and horticulture and fisheries. ILVO has to execute and coordinate scientific research in support of policy and the associated services considering sustainable agriculture and fisheries. Before a new legislation is formulated and objectives are set for a new policy instrument, it is wise to consider alternatives and the related choices for one or more policy instruments (see 5.5). For this purpose, ILVO aims, amongst others, to deliver know-how on the effectiveness of policy instruments, next to other research topics in order to improve products and production methods and to ensure their quality and safety.

Within the Ministry, there is one EVA responsible for marketing and the image of the products and services of the Flemish agro- and horticulture and fisheries: the Flemish Centre of Agro- and Fisheries marketing (VLAM). They provide for the marketing of fish products, for example by electing a 'Fish of the Year', and advertise commercials on radio and television to promote local products.

Recently a project started between ILVO and the Flemish Fish auction 'Fish2Know' in which catering schools are given the opportunity to get acquainted with the Belgian fish auctions. Lectures are given to increase the knowledge on sustainable fisheries, the fish production chain, recognizing good quality fish, professionally fish filleting and at the end a cooking workshops is organized to promote non-commercial species.

In conclusion, participation of the subsystems is often determined by political, economic, constitutional and legal provisions. At the same time, their knowledge and power of the resources will critically affect the nature of their activities and interactions. Identifying the characteristics of policy cycles and the subsystems involved, allows to define a baseline against which change can be observed. Policy making is neither a process of conflict resolution, nor is it a process solely comprised of policy-makers responding to external demands or shocks. It is mainly influenced by the activities of stakeholders and subsystem members attempting to shape the structure and operation of policy-making through activities such as venue-shifting, image reframing and policy learning (Howlett *et al.* 2009). Carefully observing stakeholder behaviour will help to break with past failures or achieve the overall policy goals by understanding the public problems and their solutions and address the right policy instruments to acquire the intended effect (Daw & Gray 2005; Ostrom 2009; Kraak *et al.* 2013).

International agreements aim at orienting national governments and their actors towards behaviour that can solve the problem at stake. Nevertheless, international instruments cannot have effect without national compliance, and compliance implies a smooth process of implementation. Policy implementation involves the application of policy tools or instruments, intended as methods through which governments address a specific problem and achieve a policy objective (Howlett *et al.* 2009). With regards to fisheries management FAO distinguishes three main categories of policy tools: input controls, output controls and technical measures (FAO 1997; Garcia *et al.* 2010). These tools are explained in the following section.

**BOX 3 - Policy cycle**

The pragmatic approach to policy-making views the policy cycle as a process of learning, in which policy makers struggle through an incremental trial-and-error process of choosing a policy, monitoring its results and then modifying their actors in subsequent policy making rounds while pursuing their original goals or modified ones (Council 2013). The policy cycle, therefore, goes beyond merely input and output stages, but also extends to monitoring and evaluative activities once output has emerged (Howlett et al. 2009). The stages applied in the policy process are depicted in Figure 3.

Agenda setting is the first step in the policy cycle and deals with the identification of problems that deserve governmental attention. The manner and format in which problems are recognized, if they are recognized at all, are important determinants of whether, and how, they will be ultimately addressed (Howlett et al. 2009). Science plays an important role in addressing problems in addition to the attention from media and NGOs. However, also the impact of causal reasoning should not be overlooked when defining problems (Howlett et al. 2009). In other words, not only knowledge derived from systematic research is utilized, but also empirical and moral decisions are relied upon to reaffirm or revise a certain problem. How the agenda is formulated might involve virtually all policy actors in addressing problems and demanding governmental attention to the matter. In the next stage, named formulation, only a subset of the policy actors, namely the policy subsystem, is involved in discussion options to deal with problems recognized to requiring governmental action. The subsystems are composed of only those actors with sufficient knowledge of a problem area or a resource at stake, to allow them to participate in a process where alternative solutions are raised to address a problem. In order to formulate good policy options, policy makers need a comprehensive understanding of the problem. By formulating a clear and meaningful problem statement, the goals of the policy are established and then objectives can be determined. In the end, it is important that policy options are eliminated, until one or only a few are left for the policy-maker to make his final selection (Howlett et al. 2009). In this next step the governments adopt a particular course of action or non-action. As suggested by the action taken in the step, a decision is taken, the number of actors involved is reduced even further to only that subset of the policy subsystem with the highest authorisation. Such example might be the elected officials, judges or bureaucrats. Policy subsystems, must be aware of how they frame their recommendations, whereas decision makers must be aware of the biases they hold.

Because decision-makers have the final say, they should aim for the most optimal solution for all actors affected by policy. Whereas only a handful of people are involved in decision-making, once the policy is translated into action, all relevant subsystems are again involved in the process. This stage can often carry on for years and the success or failure of a policy is usually determined here. Governments and institutions can influence actors and their interaction (Howlett *et al.* 2009), but not 'deterministically'. Actors may on the basis of personal beliefs and interests violate or avoid the norms and rules they are supposed to follow. 'Game theory' analyses the interaction of actors and can be applied to understand how this behaviour can influence policy implementation (Scharpf 1997; Brans & Ferraro 2011). Policy implementation should therefore be seen as a continuous process of negotiation and bargaining between decision makers and implementing officials and target groups (Barrett 2004). The final step in the process is to examine the results of newly implemented legislation, in other words to verify whether the policy goals have been achieved (Howlett *et al.* 2009). Successful evaluation is created with careful attention to its design and implementation, which begins with the consideration of the problem statement and the entire policy. The policy makers, not the evaluation researcher, must supply the program goals and criteria for success. When careful attention is paid to the evaluation step, feedback can be given to policy makers and implementation adjustments can be made (Howlett *et al.* 2009). Once the outcome of a policy is evaluated it may be readdressed at the agenda setting.

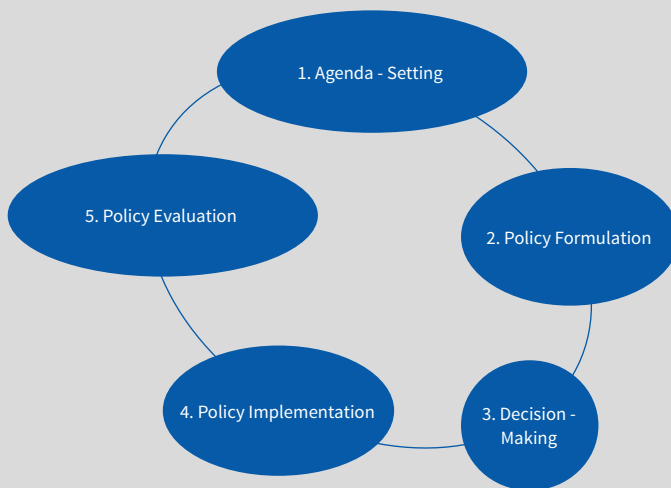

**Figure 3** The five stages of the policy cycle as formulated by Howlett *et al.* (2009). The relative number of actors involved at each stage is represented by the size of the bullets. Whereas all policy actors are involved in agenda-setting and policy evaluation, only a subset of the policy subsystems are authorized to make a final decision.

## 5.5 POLICY INSTRUMENTS

After clarifying the institutions and actors involved in policy making it becomes obvious why there is much more going on than just ‘simply’ following or rejecting scientific advice on the status of fish stocks. We will focus now on the system of rules defined by those institutes. For the purpose of the thesis, we will mainly focus on those international rules that prescribe given policy tools for fisheries management. Policy implementation involves the application of tools (instruments) intended as methods (devices) through which governments address a specific problem and achieve a policy objective (Howlett *et al.* 2009; Ferraro 2010).

Excessive fishing capacity is perceived as a problem that, among others, contributes substantially to overfishing, the degradation of marine fisheries resources, the decline of food production potential, and significant economic waste. One of the main challenges for the current CFP reform and future fisheries policy is addressing this deep-rooted problem of fleet overcapacity. Instruments to manage fisheries capacity range from measures such as regulating entry to a fishery, gear and vessel restrictions, group fishing rights, territorial user rights, total allowable catches, vessel catch limits, individual effort quotas, individual transferable quotas, taxes and royalties to buyback and decommissioning schemes. All these policy tools can be classified into three main categories: input and output control and technical measures (FAO 1997). The EU lists the instruments of the CFP in the recent Council regulation on the conservation and sustainable management of fisheries (Council of Ministers No 2371/2002). Article 4 of this regulation (also referred to as the ‘Basic Regulation’) sets forth the different types of measures, as like FAO.

### 5.5.1 Input controls limiting fishing effort

Overfishing is a major impediment to achieve ecological and also economic sustainability. Excessively high catches are the results of too much fishing effort. Therefore, fisheries policy and centralized fisheries management have adapted direct measures that aim to limit catches, and indirect measures focusing on fishing effort (Table 1).

Input controls regulate this fishing effort, intended as how much fishing can take place. According to Charles (2001) effort is determined by four main components:

- The number and size of fishing vessels (capacity control)
- The amount of time at sea (vessel usage control)
- Capacity<sup>26</sup> power (or capacity) of each vessel
- Intensity of operation<sup>27</sup>

It follows that input (or effort) controls consist of all actions aiming to reduce the amount of fishing activity. In order to limit the given number of vessels, licensing may be very effective (Charles 2001). Moreover, they also limit capacity and fishing time. Capacity can be further limited by specifying in the licences what characteristics of the vessels are allowed, such as restricting the engine power or size of vessels. Fishing time can be limited by restricting the number of days that may be spent at sea in a specific fishing area.

The advantages of input control is that they do not require an assessment of the size of the fish stock. Because, theoretically, the facility of catching fish is proportional to the stock size, the percentage of the stock caught for a given fishing effort is independent of the stock size (Walters & Martell 2004). However, experience has shown, that input controls alone are frequently ineffective, as effort restrictions fail to address the effect of technology-driven efficiency. In fact, the effort limitation encourages fishers to invest in such efficiency improvements (FAO 2002; Briand *et al.* 2004). An extreme example is the Bristol Bay red king crab fishery, where in 1993 only a limited number of pots proportional to vessel size were allowed in order to elongate the fishing season. However, due to higher capture efficiency of the vessels, the Bristol Bay king crab fishery exceeded the TAC by 65% after only four days, requiring more stringent limits policy measures (Briand *et al.* 2004).

### 5.5.2 Output controls : limiting harvesting

Output controls focus on the catch, which is the volume that can be extracted from the stock (Table 1). The simplest kind of output control is a limit on the total amount of fish that can be caught in a certain time period, often a year or fishing season, e.g. the TACs and quota management systems. However, this system alone has shown to be insufficient to safeguard sustainable fishing as each fisherman attempts to secure the largest possible share of the allowed catches by improving his fishing strategy relative to his colleagues.

---

26 Vessels may deploy a variable amount of fishing gear. In this case fishing effort would also need a factor relating to the gear usage of each vessel

27 This factor relates to the 'ambiguous matters' such as crew skills, weather conditions, and so on, which is not that easily regulated

In order to allocate to the individual fishermen some planning security throughout the entire fishing season, the national quota are divided among individual vessels, fishermen or cooperatives (Charles 2001). This type of fisheries policy, where fishermen are granted the right to determine the quantity of fish they will harvest in the long term are known as 'right-based management'. Additionally, when the trading of individual quota is allowed in a Member State, these are referred to as Individual Transferable Quota (ITQs). Obviously, not all social objectives can be achieved solely by means of these ITQs, especially if there is a desire to ensure the survival of small, less economically efficient fishery enterprises. The efficiency of ITQ has already been shown in a few European countries like Denmark, the Netherlands, Iceland and Scotland (European Parliament's Committee on Fisheries 2007; van Hoof 2013). Problems associated with the extirpation of the small scale fishery, as they are economically less capable of buying their share, has been addressed by Iceland by allocating a share of the quota directly to this sector (European Parliament's Committee on Fisheries 2007; van Hoof 2013). In the case of Flanders, the quota are distributed on a collective basis. The only producers' organisation of fishermen in Flanders, the Redercentrale, gets all the quota allocated to Belgium and then divides these quota amongst its members through its quota-commission. According to the last, the Flemish government has opted to use non-transferable quota as the extra costs associated with the implementation of ITQs would prevent investments in innovation and more sustainable techniques by the Flemish fleet.

Other unforeseen problems resulting from TAC quota management systems are the practices of high grading, illegal catches or misreporting of catches. High-grading arises as a result of differences in value between individuals of the same species. As the actual catch consists of fish from different length/age groups and quality levels, they represent different economical values. Fishermen who are tempted to land only the most valuable individuals of a given fish species, can discard less valuable individuals of the same species. Consequently, the quota is filled with high-graded fish. This practice reduces fish stocks without any benefit to the consumer. According to the United Nations, discards in the Northeast Atlantic are among some of the highest, at 1.3 million tons per year, of which 900,000 tons per year is located in the North Sea.<sup>28</sup> To remedy such shortcomings, the Commission has proposed a ban on discards.

---

28 L. Smith, 'Trial of discard ban gives boost to fisheries reformers' 10 April 2012, Retrieved 15 July 2012, <http://www.fish2fork.com/en-GB/news-index/Trial-of-discard-ban-gives-boost-to-fisheries-reformers.aspx#.T4cJ8yswXe4> and Alverson, D.L.; Freeberg, M.H.; Pope, J.G.; Murawski, S.A. A global assessment of fisheries by-catch and discards. FAO Fisheries Technical Paper. No. 339. Rome, FAO. 1994. 233p.

**Table 1 Classic approaches to fisheries management focus either directly on restricting catches or on limiting fishing effort (Bollmann et al. 2010).**

<b>Output &gt; Catch</b>	<b>Input &gt; Fishing effort</b>
<b>Total Allowable Catch</b> Limits the maximum catch per species	<b>Fishing licences and capacity restrictions</b> Granting of fisheries licences Restrictions on fish production
<b>Landing fees</b> Introduces payments per ton of landed fish	<b>Technical restrictions</b> Criteria to increase selectivity Bans on certain fishing practices
<b>Individual (transferable) quota</b> Allocates shares of the TAC to individual fishermen/fishery enterprises	<b>Subsidies/taxation of inputs</b> Fuel subsidies Support for modernization programs
<b>Selectivity criteria (age/sex)</b> Establishes minimum size criteria	<b>Limits on the number of fishing days</b> Number of days at sea Compliance with closed periods

### 1.5.3 Technical measures

Various technical measures address the how, when and where of fishing. They impose restrictions or constraints to regulate the output which can be obtained from a specified amount of effort. Some of the most relevant ones according to Charles (2001) are:

- Gear restrictions (or fishing method), such as mesh-size, gear prohibitions, mouth openings of nets and traps, and so on
- Minimum landing size of fish species (e.g., in order to protect juveniles)
- Time restrictions and closed areas
- Prohibitions of destructive methods, e.g. the use of dynamite and poison, intentional cleaning of the seafloor



In other words, these measures generally attempt to influence the efficiency of the fishing gear. Gear restrictions affect the type, characteristics and operation of a fishing gear. These type of restrictions, e.g. minimum mesh size and mouth opening of nets or traps, usually aim at controlling fishing mortality on a particular component of the resource, such as smaller individuals or by-catch species.

### *Marine Protected Areas*

One kind of technical measure, the use of (temporary) closed areas, deserves some more attention. Similar to gear restrictions, such closures can be used to protect a component of a stock or community. Often, this instrument is used to protect spawning areas during a certain period of the year. However, authorities will have to monitor available effort and specify appropriate closed areas or seasons such that the effort expended in the open areas does not exceed the sustainable levels for the resource. As a MPA limits access by fishers to an area in some way, it could be classified as an extreme form of an input control instrument. However, there are many shades of grey between the different types of MPAs and it may be better to think in terms of a continuum between absolute prohibition of access (often called a 'no-take' reserve) and relatively minor restriction such as limitation on a specific gear type.

MPAs have become particularly important in the international debate as a tool for fish conservation and marine ecosystem restoration (Gaines *et al.* 2010; Colléter *et al.* 2012). The purposes to design MPAs may differ. For example, MPAs might be designed to protect marine living resources and habitats (ecological benefits), to protect traditional marine-based communities (social benefit), provision of revenue and employment from fisheries production (economic benefit), or to protect historic resources (cultural benefit) (Charles 2001; Ferraro 2010). Furthermore, there is a distinction between an area closure that is solely established to ban a certain fishing activity and multiple-use management areas, which allow a range of activities, but with appropriate restrictions to protect value attributes of the area. For example, tourist operators might be restricted to certain mooring locations to limit anchor damage and fishers might be restricted on the use of certain gear. Thus the consultative and legislative context in which multiple-use areas are established and managed is likely to be markedly different from that which obtains when an area is established solely within a fisheries management domain ([www.fao.org](http://www.fao.org)). In the context of MPAs aiming to enhance depleted or overexploited fish stocks, we will focus on the ecological benefits. Examples where closed areas have successfully restored fish stocks are well documented. Positive effects have been observed in relation to an increased mean fish population size, biomass and density (Mosquera *et al.* 2000; Halpern &

Warner 2002; Gell & Roberts 2003; Blyth-Skyrme *et al.* 2006). However, the effectiveness of time and area closures to reduce the fishing impact on the target species and on the entire trophic network is still poorly known (Murawski *et al.* 2010; White *et al.* 2010b; Colléter *et al.* 2012). In an attempt to restore cod stocks, an area named the 'cod box' was closed in the northeastern North Sea. However, this led to a shift in fishing effort to other species and habitats not protected by the closure (Dinmore *et al.* 2003; Fulton *et al.* 2011). If marine reserves and other MPAs are to provide significant conservation benefits to a species they must be scaled-up e.g. the Papahānaumokuākea National Monument, which covers almost 360,000 km<sup>2</sup> (Blyth-Skyrme 2006; Gaines *et al.* 2010). Given the potential economic and social costs of such large individual reserves in heavily populated coastal areas, this option is unlikely to be common. A number of nations e.g., Australia, the United States; have pursued an alternative approach to scaling up marine reserve benefits: networks of multiple MPAs (Gaines *et al.* 2010 and references therein). By aggregating the benefits of multiple MPAs, the network may have larger impacts.

### 5.5.4 Effectiveness of the instruments

Since 1980, the EU created its own set of technical measures. Over the years the areas for which these measures were created expanded. In the beginning the area stretched from the Kattegat to the Bay of Biscay, while this zone was extended with the fishing grounds off the Iberian Peninsula, the Mediterranean Sea and the Baltic Sea in the mid-2000s (Suuronen & Sardà 2007). Over the years, a steady growth in the number of tools for fisheries management has been observed (Figure 4). Taken together with the fact that the set of measures applied is not identical for all areas and species, due to local conditions, the legal framework for these measures has become a maze. Member States, stakeholders and the EP state that these technical measures currently in force are too complex and difficult to understand, control and enforce. The following questions arise: Why then, do governments pick a certain mix of instruments in order to achieve the goals they have put forward? Why is a certain mix optimal and the instruments it contains counterproductive or complementary? (Howlett *et al.* 2005). The choice of a certain policy mix depends on two independent variables: the level of state capacity and the level of policy-subsystem complexity. The intersection between these two variables is determinative for the instruments to be chosen (Howlett *et al.* 2005). The reason as to why a set of policy instruments are effective is twofold. First criteria are related to the effects of the instruments (Mickwitz 2003). A distinction should be made between anticipated effects and unanticipated side effects (see Chapter 7).

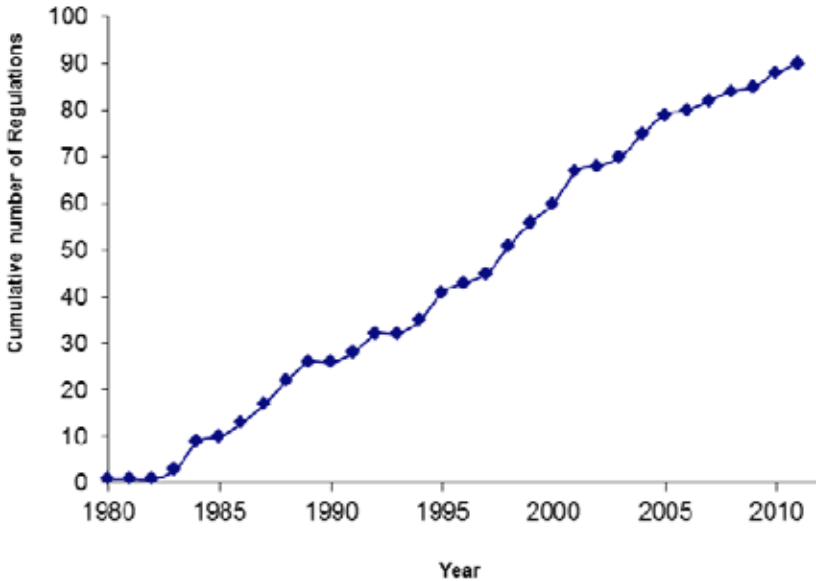

**Figure 4** Over the past decade EU fleet capacity has been reduced coupled to the increase of fisheries regulations. However, in the majority of cases the still available fishing capacity is perceived to be not in line with the available fishing opportunities (European Union 2012b).

When evaluating a policy instrument, one should try to investigate whether or not the instrument attained the anticipated effects and whether or not side effects have occurred. A second criterion is an economic one, namely efficiency: are the benefits worth the costs? Although it is hard to use economic criteria in evaluating environmental policy instruments they should not be ignored. A third and final set of criteria is based on democracy. Two indicators may be put forward: legitimacy and participation. The former is related to the degree to which the individuals and organizations that are affected by the policy accept the policy instrument. Participation then tries to see to what extent the different stakeholders were heard in the process of creating the policy instrument (see 6.3 and Figure 1). At last one should not forget the manageability of implementability of a policy instrument (Salamon 2002). This relates to the extent to which it is difficult to operate the instrument. If a policy instrument is complex and requires the involvement of a high number of actors, it will be hard to manage.

As such, the current technical measures are regarded ineffective to accomplish a sustainable fishery (Suuronen & Sardà 2007; EC 2013). The new CFP aims to improve dialogue with stakeholders and their involvement in the decision-making process in order to consider the broad impact of human activities on multiple species interactions. Furthermore, recommendations regarding policy instruments as stated by Kraak *et al.* (2013) include:

- Management through catch rather than landing quota
- Internalisation of the costs of exceeding quotas
- Use of more selective gear types
- Development of appropriate metrics as a basis for regulatory measures and for evaluations
- Participatory governance
- Fishery-based management
- Flexibility in fishing strategy at the vessel level







# Chapter 6

## Reform of the CFP

Foto: © Hans Hillewaert





# Chapter 6

## Reform of the CFP and likely changes after revision by the Council and Parliament

The European Union committed to the outcomes of the World Summit on Sustainable Development in Johannesburg, that stocks should be recovered to levels that can produce maximum sustainable yields (MSY) by 2015 where possible. The fundamental pillars of the revised CFP are an ecosystem-based management and the precautionary approach. With this reform the EC hopes to treat problems in the EU fishery alike, namely the high percentage of community fisheries that are either overfished or beyond safe biological limits, the negative economic effects of overfishing, the lack of incorporation of conservation objectives, the inadequate scientific data, the harmful subsidies, the centralized management that has not included regional needs and the inability to administer expensive oversight and enforcement. In other words the CFP aims to sustainably exploit living aquatic resources, taking into account the environmental, economic and social aspects (European Communities 2002). The CFP does neither set priorities for these objectives, nor does it explicitly state to achieve its goal within the economic and social conditions (COM 163 2009). However, this is not perceived as an obstacle as 'the economic and social viability of fisheries can only result from restoring the productivity of fish stocks'. Therefore, no conflict exists between ecological, economic and social objectives in the long term (COM 163 2009). These main objectives of the revised CFP are:

- Maximum Sustainable Yield MSY: To rebuild individual stocks by 2015 to the status at which they can produce MSY, within the constraints of the ecosystems it inhabits (European Council 2013, art. 2)
- Establish multi-annual plans by 2017 that follow scientific advice and that include conservation measures to maintain or restore fish stocks above levels capable of producing maximum sustainable yield (European Council 2013, art. 9)
- Regionalization: To move away from micromanagement at the EU level, and ensure that rules are adapted to the specificities of each fishery and sea area (European Council 2013, art. 17)
- Landing obligation: To accomplish a discard ban by 2016 for all species (European Council 2013, art. 3,15)

- Limit subsidy payments to sustainable fishing practices by making financial assistance to operators from the EU conditional upon compliance with the CFP rules. Financial assistance shall not be granted to an operation that violated or jeopardised the sustainability and conservation of marine biological resources, biodiversity, habitats or ecosystems in the past (European Council 2013, art. 51). Also limit fishing opportunities and suspend payments to the Member State if it fails to adopt appropriate measures to reach sustainability (European Council 2013, art. 16)
- Transferable fishing Concessions (TFC): To have, by 2014, Member States introduce TFC, to entitle fisherman to exploit marine resources for only a limited time. After this time, the TFC has to fall back on the Member State, who is free to allocate it again using the same allocation criteria or different ones. Selling, leasing or swapping of TFCs can only happen under strict conditions as only owners of registered and active vessels with the purpose to use them on a licensed and active vessel, can buy TFCs.
- Ensure an ambitious External Dimension Policy. The Union shall act in line with international commitments, obligations and policy objectives and consistently with the objectives set out in Articles 2, 3 and 4 of the CFP (European Council 2013, art. 16). Furthermore, the integration of environmental protection is required into all activities and policies of the EU, including the new CFP (TFEU art 11).

When considering the EAFM in a fisheries policy context, as proposed in the CFP reform, a great number of diverse stakeholders usually feel involved, which renders the challenge of achieving mutual agreements and obtaining results even more difficult. Finally, an agreement was endorsed between the Council and the EP and the new regulation on the CFP should enter into force by 01 January 2014 with a progressive implementation of the new rules. Below we briefly discuss how the above mentioned arguments presented by both institutions might affect the end result of the proposed changes of the CFP.

### **6.1 MAXIMUM SUSTAINABLE YIELD**

The aim of the World Summit on Sustainable Development (Johannesburg 2002) was to: ‘maintain or restore stocks to levels that can produce the maximum sustainable yield with the aim of achieving these goals for depleted stocks on an urgent basis and where possible not later than 2015’ (European Council 2013, art. 39).

The flexibility implied with the phrase ‘where possible’ gives EU Member States a precedent to dilute the EC’s proposal during negotiations, leaving the desired objective vague. Meeting MSY might imply a decrease of fishing possibilities leading to an adjustment of the fleet capacity (e.g. decommissioning). Many EU ministers fear this adjustment period, as this may need unpopular political decisions. Nevertheless, most Member States supported and eventually agreed upon the MSY concept. However, the wording ‘where possible’ opened the door for negotiating the deadline: ‘achieving MSY for all stocks at the latest by 2020’<sup>1</sup>.

The Council agreed that MSY has to be reached by 2015 where possible and ultimately by 2020 in order to achieve a balance between fleet capacity and available resources providing adequate social and financial measures (Churchill & Owen 2010). Once MSY is achieved and sustained, fisheries should experience an increase of profits and subsequently greater stability. Ultimately, governments will no longer need to subsidize the industry and could allocate funds elsewhere, enhancing the economic benefits (Saarinen & Monar 2012). The vote in the Fisheries Committee of the EU Parliament supported the key elements of the Commission’s reform including that fish stocks should be managed by 2015 on a level that allows them to recover by 2020 at the latest (20<sup>th</sup> Dec 2012)<sup>2</sup>.

## 6.2 MULTI-ANNUAL PLANS

Multi-annual or long-term plans are one of the great innovations of the 2002 reform of the CFP. Initially introduced for stocks which had been depleted to dangerously low levels (‘recovery plan’). For some commercially important stocks, multi-annual plans (MAPs) are established at the international level. One of the most important long-term plans is the 15-year recovery plan for Eastern bluefin tuna which was adapted by the ICCAT in 2006.

As of today, MAPs are being standardized as the method of choice for managing the EU’s major commercial fish stocks. As, MAPs describe clearly defined biological targets, they remove uncertainty for the industry and prevent short-term influences which often take the upper hand. In other words the emphasis is on ensuring that fisheries are managed sustainably in the long term. The definition of targets in terms of fishing mortality, rather than simply the absolute quantity of fish in the sea (stock biomass), makes it possible to adopt a single biological goal whatever the condition of the stock. Furthermore, maximum limits are set on the inter-annual variation in TAC to provide a minimum stability to the

1 <http://cfp-reformwatch.eu/2012/05/ministers-we-support-msy-but>

2 <blogs.ec.europa.eu/damanaki/tag/maximum-sustainable-yield>

fishing industry. Moreover, these MAPs do not simply provide a mechanism for setting TACs, they lay out a range of measures to support sustainable management, including closed areas, technical measures on mesh size and gear, and careful monitoring, inspection and control. Additionally, MAPs have also been one of the main vehicles through which effort management (limits on annual days at sea) have been introduced into the CFP. Although the fixed limitations on the annual variation in TACs provide a certain security for the fisherman, at the same time the current MAPs have been criticized for being too rigid<sup>3</sup>. For example, North Sea herring is part of a long term management plan, which means that the quota cannot change with more than 15% from the previous year. However, scientists calculated that the quota could increase with 139%, leaving a vast amount of biomass that otherwise could be available for harvest. Furthermore, problems have been observed in the opposite direction, were MAPs fail to meet their objectives, such as the Cod Recovery Plan (Kraak *et al.* 2013). Under the current procedure the necessary amendments must pass through the co-decision process, which could delay the agreement of a new plan for two years or more<sup>4</sup>. To circumvent these problems, the STEFC proposed that MAP have to be regularly assessed against their objectives. Even more, management plans should be evaluated with regards to their effectiveness, utility, efficiency (cost-effectiveness) and, their sustainability (Salamon 2002; Mickwitz 2003; EC 2011; Kraak *et al.* 2013).

Within the context of the current CFP reform, the Commission proposes a deadline by which fish stocks should be restored to MSY levels no later than 2015. If they want to meet this deadline, the timing by which these multi-annual plans have to be agreed upon will be crucial. However, as of 2002 only 22 MAPs have been agreed upon, representing only one-quarter of the EU's commercial stocks<sup>5</sup>. One of the main reasons for this delay is the inter-institutional debates over the legal base (BOX 2 Lisbon Treaty).

---

3 <http://www.publications.parliament.uk/pa/cm201012/cmselect/cmenvfru/1563/156309.htm>

4 <http://www.publications.parliament.uk/pa/cm201012/cmselect/cmenvfru/1563/156309.htm>

5 <http://www.publications.parliament.uk/pa/cm201012/cmselect/cmenvfru/1563/156309.htm>

### 6.3 REGIONALISATION – REGIONAL BASED MANAGEMENT

As a general rule, the Council is supportive of measures that increase flexibility and unsupportive of provisions that reinforce EU authority over national fisheries. Following the developments in the 1970s (e.g., including the extension of the EEZs and the introduction of the principle of equal access), the shift to EU exclusive competence in fisheries conservation was unpopular, but legally indispensable (Kraak *et al.* 2013). For this reason the proposal on regionalization by the EC has been welcomed by both the Council and the EP with great enthusiasm<sup>6</sup>. Regionalisation cannot add an additional level of decision-making under the current TFEU. Ideally, interaction of the Member States with the Advisory Committees (AC) would replace interaction of the Member States elsewhere, which could lead to the more efficient use of resources. Furthermore, this approach for decision-making allows for closer involvement of fishers in ‘specific’ technical decisions and for stakeholders to fully participate in decisions and debates about fisheries policy implementation (Churchill & Owen 2010).

The EC proposes to leave the implementation of regulations in the future almost entirely to the Member States. This means that Member States will not only be responsible for adopting ecosystem-based fisheries management, but also responsible for the enforcement. The UK fisheries minister, Richard Benyon, explained why this would lead to a better management: ‘We are in favour of greater localisation because it will lead to better management of fisheries – the situation in the western Mediterranean, for instance, is very different to that in the North Sea, and the centralisation of powers in the hands of the European Commission does not always reflect that.’ In May 2012, a workshop ‘GAP2’ was organised in London which brought together representatives from Belgium, the UK, the Netherlands and Denmark, with the purpose of discussing the possibilities of using the North Sea basin as a pilot for regionalisation. One of their suggestions was to use the RACs as a base for the AC (Figure 1).

---

6 [www.guardian.co.uk/environment/2012/apr/27/eu-fishing-quota-reforms?INTCMP=SRCH](http://www.guardian.co.uk/environment/2012/apr/27/eu-fishing-quota-reforms?INTCMP=SRCH)

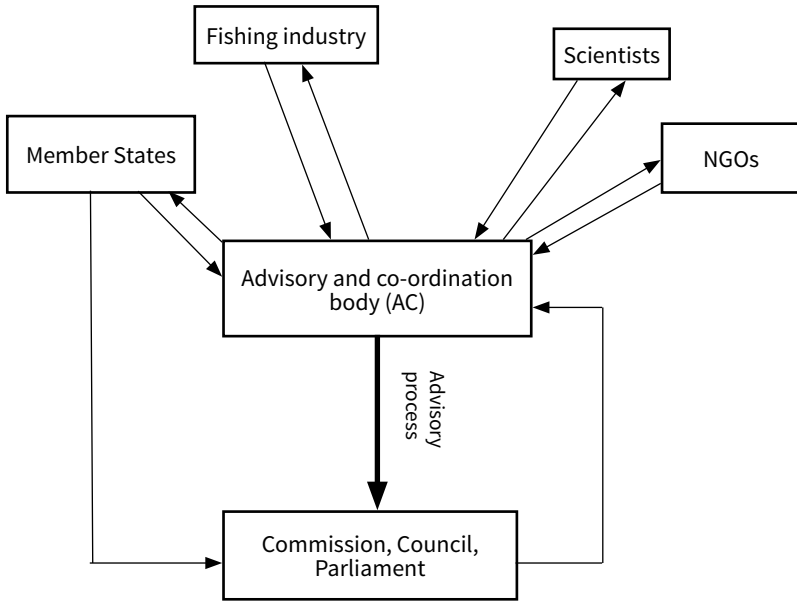

**Figure 1 The proposed structure for regional based management by GAP2 where all different actors are represented and able to communicate directly to European decision making institutes**

However, several practical issues should be addressed before such local management could be implemented. Some of these are :

- What decision-making or governing entities could be created to implement ‘as local as possible’ fisheries management decision-making?
- What is legally possible under the Treaty? What can be changed to enable regional fisheries management?
- Is the Treaty flexible enough to delegate powers to Member States through multinational regional decision making?
- Which decisions should remain at the Union level?
- How can we make ‘regional’ bodies accountable?
- How can we use the regional advisory committees or other stakeholder forums to leverage co-management benefits?

Legal experts both within and outside the Commission are currently exploring whether it is possible to constitute legally recognizable ‘regional bodies’. Opinion suggests that the RACs cannot simply be transformed into legally constituted regional management institutions, as they would not have legal competence for making fisheries management decisions. It has also been suggested that local co-management may not be a viable option under the constraints of the Treaty. One of the key questions being asked at the moment is: how, under the Lisbon Treaty Member States can form multinational regional bodies that can take responsibility for making, implementing and enforcing fisheries management decisions (<http://ocean2012.eu/>).

For Member States like Belgium, with a historical fishing pattern spread over a very large area, the regionalization is a rather cumbersome item. Belgian fishermen fear for an accumulation of different (technical) measures in different regions and the Belgian administration fears to be confronted with an accumulation of workload as Belgium is involved in at least three regions and RACs (NWWRAC, NSRAC and SWWRAC). Current Belgian policy objects to the replacement of the actual top-down micro-management of ‘Brussels’ by bottom-up regional micro-management.

## **6.4 THE LANDING OBLIGATION**

A lot of controversy characterizes the proposal of a discard ban, especially in the Council (<http://cfp-reformwatch.eu>, Sardà *et al.* 2013). While some countries do support the measure, others strongly oppose it. The UK government, for example, is very positive about a possible implementation because of recent successes with a trial discard ban<sup>7</sup>. Other countries, like Lithuania and Belgium, are not as optimistic and fear for the financial and practical implications of a landing obligation. In Belgium bottom trawling is a common practice, which is characterized by high discard volumes (PEW 2009). On board storage of discards will interfere with marketable fish, resulting in enhanced fuel consumption as vessels have to travel more frequently to the harbour. Prices of normally discarded fish will inevitably be lower, leading to reduced revenue per fishing trip.

---

<sup>7</sup><http://www.fish2fork.com/en-GB/news-index/Trial-of-discard-ban-gives-boost-to-fisheries-reformers.aspx>

Another problem associated with the discard ban was during the negotiations with Norway<sup>8</sup>(Poos *et al.* 2010; Feekings *et al.* 2012). To accommodate the negative side-effects of the discard practice, Norway established a set of regulations and measurements, e.g. a discard ban was introduced on cod and haddock in 1987 and gradually expanded to all catches by 2009 (with some minor exceptions)(DG MARE 2012). Renewed negotiations between the EU and Norway were needed, as Norway decided to revoke the Skagerrak agreement in 2012. Norway argued that this agreement was not compatible with the UNCLOS art 123<sup>9</sup>. Vessels of the EU and Norway would have to comply with coastal state fisheries legislations in the Skagerrak, however, as the legislations are markedly different (the EU having no discard ban yet), this will considerably disrupt the traditional fishery in the Skagerrak, encouraging the EU to harmonize their measures and legislations (Petter Johnsen & Eliassen 2011).

Ultimately, the Council proposed a gradual, fishery-based discard ban, starting with a ban in the pelagic fisheries by 2014<sup>10</sup>. The sector was also in favor of a gradually introduced ban, but only for the stocks that are on the edge of collapse. This is understandable, especially given the difficulties Member States would have to comply with these obligations (e.g. the EC has not yet allocated funds to compensate). A discard ban does not only affect the fishing sector, as it will require radical changes of the Belgian demersal fishery, it also raises questions in regards to governance. Member States would be required to set up remote electronic monitoring systems to supervise enforce the discard ban (DG MARE 2012). Nonetheless, this way of control and enforcement may remain expensive for Member State

---

8 More than a quarter of the fish caught by European fishing boats are actually taken outside EU waters. Around 8 % of EU catches (2004-06) are made under fishing agreements with countries outside the EU, while another 20 % are taken on the high seas, mainly in regions under the care of regional fisheries management organisations. Several European Union Member States have special territories which, for historical, geographical, or political reasons, enjoy special status within or outside of the European Union. These statuses range from no or limited derogation from EU policies, limited inclusion in EU policies, or none at all. Most of the territories which are outside the EU nonetheless have a special relationship with the EU. For example, the Faroe Islands, a self-governing nation within the Kingdom of Denmark, are not part of the EU, as explicitly asserted by both Rome treaties. The relations with the EU are governed by a Fisheries Agreement (1977) and a Free Trade Agreement (1991, revised 1998). The main reason for remaining outside the EU is disagreements about the Common Fisheries Policy.

9 UNCLOS art 123 can be used as a legal basis for joint initiatives by states bordering enclosed or semi-enclosed areas. Those states should cooperate and coordinate (a) management, conservation, exploitation and exploration of the living resources of the sea; (b) implement the rights and duties with respect to the protection and preservation of the marine environment and (c) their scientific research policies.

10 7165/1/13 REV 1 PECHÉ 84 CODEC 499, 10. Docs. 8799/13 PECHÉ 169 CODEC 882, 9003/1/13 PECHÉ 184 CODEC 945 REV 1



## 6.5 TRANSFERABLE FISHING QUOTA (TFC) AS A SOLUTION TO OVERCAPACITY

It has been recognized worldwide that one of the main fishing problems is that there are too many boats for declining fish stocks (COM 163 2009; DG MARE 2012). The Commission's reform proposals aim to introduce a system of rights-based management using transferable fishing concessions (TFCs) to eliminate overcapacity (Hilborn *et al.* 2003a). The idea is to minimize the competition for a limited resource by giving individual fishing rights to fishermen, vessels, enterprises, cooperatives or fishing communities (EC 2011; van Hoof 2013) to catch a certain amount of fish. Among the potential benefits, TFCs may stabilize a fishermen's income and allow them to fill in their quotas whenever they like, spreading fishing effort (Fulton *et al.* 2011; Kraak *et al.* 2013; van Hoof 2013). Furthermore, they eliminate seasonal market gluts, potentially increasing the prices fishermen can command for their catch (Schrope 2010; Allison *et al.* 2012; van Hoof 2013). On the ecological side, catch shares can be designed to limit the catch of non-target fish<sup>11</sup>, increase populations of regulated fish or even reverse collapsed stocks (Schrope 2010). The advantages and workability of the TFC system have led to successes in many countries, including the US (Schrope 2010; Allison *et al.* 2012), New Zealand, Canada and Iceland<sup>12</sup>. Within the EU there is a tendency regarding development of property rights in fisheries. Some countries like Denmark, including Faroe Islands, United Kingdom or Ireland and Belgium performed national quota management, others like Italy and the Netherlands implemented ITQ systems (Kraak 2011). The Dutch individual vessel quotas for sole and plaice were already introduced in 1976, within the framework of the North East Atlantic Fisheries Convention (Schrope 2010; Allison *et al.* 2012). The aim was to increase compliance (from an economic rationale to violate the system, towards social control and peer pressure) and reduce costs to society (Kraak 2011). It clearly played a role in bringing back legitimacy to the system and the costs of the inspection service and registered infringements have been reduced (Kraak 2011).

Notwithstanding, many Member States were reluctant towards mandatory TFC. Their concerns are valid, as many fear the possibility of a concentration of quota with investment funds or so-called 'slipper skippers', private individuals who own fishing rights with the purpose of generating income from their leasing, without being active fishermen (Smit 2001; van Hoof 2013). This concern was confirmed by the EP who stated that only active fishermen should be granted TFCs.

---

<sup>11</sup> One way catch shares may enable this is by the combination of management tools, such as the discard ban, where throwing fish overboard becomes illegal (Schrope 2010)

<sup>12</sup> <http://www.economist.com/node/21548240>

Furthermore, small scale or artisanal fishers should get preferential access to the resources excluding them from the TFC system as they provide more jobs than large-scale vessels and have more added value to coastal communities (van Hoof 2013). This justification not only reflects social concerns but also mirrors the commission's statement on the importance of small-scale fishermen and the reasons for their exclusion from the TFC system (Allison *et al.* 2012; van Hoof 2013)<sup>13</sup>.

Experiences from other countries, like the Netherlands, showed that the ITQ system does not come about overnight but requires optimization over a period of years (EC 2011; van Hoof 2013). It is important to bear in mind that the TFC system alone will certainly not end overfishing. High grading and discard problems for example will remain as TAC and ITQs are monitored in terms of fish landings, not in actual catches. The Dutch case did reveal that catch rights create an incentive for a reduction of input of labour and capital to a fishery and for use of the resource in a more efficient, sustainable way (van Hoof 2013). As a result of all the pros and cons, the Council decided in June 2012 that TFC should be introduced by Member States at a voluntary basis rather than mandatory. Subsequently the EP omitted the entire chapter on TFC and a voluntary introduction is possible in each MS.

## 6.6 FINANCING

Subsidies, being domestic decisions that affect regional and international common goods, are very controversial as they effectively counter the economic incentive to cease fishing when it is unprofitable (World Bank 2009). The reduction or suppression of subsidies seems to be the main measure required against overcapacity in many FAO member countries and by most environmental NGOs (van Hoof 2013). However, for the EC it becomes difficult to hold Member States accountable for paying out 'harmful subsidies', generating excess fishing effort and fishing capacity, because they would need to monitor whether effort reduction took place in association with capacity building (Garcia *et al.* 2003). Furthermore, a number of countries (and most developing ones) argue that 'good subsidies' are needed to steer fisheries development in the appropriate direction (including towards capacity reductions) and to protect small-scale industries and coastal communities' livelihood in the process. This concern is also raised in the new European Maritime and Fisheries Fund (EMFF), as funding for the building of new vessels should be impossible (COM 804 2011). However, during the negotiations numerous countries have made requests to continue

---

13 [http://www.cfp-reformwatch.eu/wp-content/uploads/2012/01/tfc\\_en.pdf](http://www.cfp-reformwatch.eu/wp-content/uploads/2012/01/tfc_en.pdf)

public funding for fisheries<sup>14</sup>. Some main opponents of removing subsidies are large-scale fishing lobbies in an attempt to maintain profitability and ministers afraid to make unappealing decision that may not pay off until the term of future ministers (Daw & Gray 2005; World Bank 2009).

To the contrary, funding should be made available for adaptation purposes to reduce unwanted catches, through research in order to develop more selective and environmentally friendly gear (COM 804 2011). For example, to change net sizes, or modifying ships which will allow other, new fishing techniques which will improve selectivity. The EU has therefore encouraged Member States to provide financial support for pilot projects aiming at improving fishery selectivity (see pilot projects of the Belgian government<sup>15</sup>). Although further support by the EU will be needed to compensate for the financial losses due to the landing obligation<sup>16</sup>, the World Bank has suggested that any subsidies should be temporary and be included in a broader strategy to improve fisheries management and enhance productivity. However, recent studies have indicated that fishermen sometimes enjoy substantial financial benefits when subsidies are eliminated, for example when shifting to more selective gear (Saarinen & Monar 2012)<sup>17</sup>. Whereas government officials normally seem reluctant to reduce subsidies fearing a financial crisis in the sector, such studies and cases should help encourage them to change their strategy.

Whereas the CFP aims to guide national governments and their actors towards behaviours that solve current problems, such as overfishing, the Council and EP have to reach a consensus on the proposals made by the EC. In order to better understand domestic policies and their subsequent reform, it is important to consider international policy-making. The resistance of the Member States to accept a complete landing obligation, for example, is one of the reasons why the deadline to achieve this aim was continuously postponed (Willy Vanhee and Hilde Vanhaecke *pers. comm.*). On the other hand, domestic policy has to be evaluated in order to better understand to what extent international regimes may influence national public policy and, hence, be successful (Heymans *et al.* 2011). In particular, the mobilization or opposition of state and societal sectors at the national level determines the capacity of the state to reform (Brans & Ferraro 2012). The next section will enter into greater detail.

---

14 <http://cfp-reformwatch.eu/2011/06/eight-more-member-states-ask-for-fisheries-subsidies>

15 <http://lv.vlaanderen.be/nlapps/docs/default.asp?id=218>

16 <http://cfp-reformwatch.eu/2011/12/european-parliament-rapporteurs-and-timetables/>

17 <http://cfp-reformwatch.eu/2011/05/removing-subsidies-makes-fisheries-more-profitable>





# Chapter 7

**Why is current management  
so challenging?**

Foto: © Karl Van Ginderdeuren



# Chapter 7

## Why is current management so challenging?

The loss of fisheries resources does not only affect the ecosystem directly and indirectly (through food webs and ecosystem interactions), but also causes socio-economic losses (e.g., loss of income and employment, decrease of food security and drawback in poverty reduction). This is particularly obvious in developing countries (Hanna 2003). Chapter 2 has stressed that, for the last two decades, international organizations have promoted the policy goal of sustainable use of fisheries resources. A shift in focus from exploitation to the responsible use of fisheries resources is, indeed, obvious in the four global agreements that have addressed all kinds of marine fisheries under the national jurisdiction of coastal states, the EEZ. This change in overall objectives coincides with an increase in the scientific knowledge available at the time that the four documents were issued. Nevertheless, Castilla & Defeo (2005) argue that “sound fishery science is a necessary, but not sufficient, condition for the sustainability of marine resources”. Institutional success depends on the interaction between science and politics that translates knowledge into feasible policy decisions (Pielke 2007; Ferraro 2010; Floor *et al.* 2013). Environmental problems need to be approached not only from an ecological perspective and with only biological criteria in mind, but explicitly integrating the socio-economic impacts into fisheries policy will be required (Ostrom 2009; Wilson 2009; Fulton *et al.* 2011; Kraak 2011). As the success of the policy will heavily depend on social acceptance and consensus, which in turn leads to improved scientific legitimacy and higher compliance with the regulations (Ferraro 2010; Österblom *et al.* 2011). At the same time, traditional arrangements must accept to eventually adapt to new purposes (Ferraro 2010). Countries like Norway and North America have a relatively well designed fisheries policy, as measured by sustainability of their fish stocks (Worm *et al.* 2009; Österblom *et al.* 2011). Lessons from their fisheries learns that sustainable quota are contribution to recovering stocks, which reduces the incentives to cheat, in combination with strong enforcement and monitoring (Österblom *et al.* 2011).

In the following paragraphs we address how the interaction politics, science and stakeholder behaviour effects the success or failure of fisheries policy. Some of the main problems are discussed with the aim to present some solutions which take into account the before mentioned challenges.

## 7.1 PROCESSES OF ECOSYSTEM CHANGE – INTERCONNECTED ECOSYSTEMS

Our oceans and in particular coastal waters have been and continue to be affected by heavy anthropogenic pressures. Not any area in the ocean, not even the most remote one, remains untouched by human activities (Halpern *et al.* 2008). This has led to a widespread degradation of marine habitats, depletion of resources and loss of biodiversity at the levels of ecosystems, species and genes (Katsanevakis *et al.* 2011). Next to the heavy anthropogenic pressure, natural processes like climate change, also influence the structure and functioning of marine ecosystems and the use of coastal zones (Megrey *et al.* 2009). The scale at which each of these drivers affect the ecosystem is highly variable both in time and spatially. Whereas latitudinal gradients and depth have a strong impact on the biogeographical ranges of species (Drinkwater *et al.* 2009; Mueter *et al.* 2009), the variation in plankton is best explained by large scale processes such as ocean circulation, upwelling and/or frontal systems (Belkin *et al.* 2009; Link *et al.* 2009; Mueter *et al.* 2009). In turn these oceanographic features are heavily impacted by temperature. Temperature increase and the accompanying melting of the ice cap will for example, affect on a large scale the convection<sup>1</sup>. In Europe, the North Atlantic current system transports enormous amounts of heat to the north. However the melting sea ice will disrupt this process causing latitudinal range shifts of species on a regional scale (e.g. Bay of Biscay (Rice *et al.* 2010) and North Sea (Kenny *et al.* 2009)). Furthermore, recruitment in several fish stocks is significantly correlated with temperature (Mueter *et al.* 2009), directly affecting resources availability fishermen are depending upon.

Fishing remains one of the largest factors modifying marine ecosystems with a direct impact on the food web. Most fisheries focus on top predators (Crowder & Norse 2008; Pauly *et al.* 1998), which are fished at unsustainable rates (Myers & Worm 2003). Others target forage fish, such as Peruvian anchoveta (*Engraulis ringens*), which are important prey of larger fish, marine mammals and seabird predators. Fishing does not only remove biomass from particular trophic levels, it also has indirect effects such as removing non-target species, altering habitat, modifying behaviour, and providing subsidies to scavengers (Crowder & Norse 2008).

---

1 Convection refers to the phenomenon of the circulation of large bodies of water in the ocean. Depending on the salinity and temperature of the water, water density varies. Heavy cold, salty water sinks to great depths. Although convection only occurs locally in the polar regions, it propels thermohaline circulation, which spans the globe like a giant conveyor belt.



As a consequence, fishing leads to a reduction in species diversity, total biomass and the provisions of ecosystem services<sup>2</sup> (Micheli & Halpern 2005). Crowder & Norse (2008) hypothesised that food webs with strong interactors and high degrees of specialization (e.g. low omnivory) are most susceptible to overfishing rather than a complex food web. A healthy ecosystem or species-rich ecosystem is buffered from collapse by having a food web with close interactions among species and high species diversity per trophic level (Bascompte *et al.* 2005; Micheli & Halpern 2005; Schindler *et al.* 2010). This means that whenever a trophic niche is made available by species removal, alternative species can increase in abundance and occupy the empty niche (Crowder & Norse 2008).

These complex interactions and the large spatial scale of marine ecosystems suggest that marine ecosystems often demonstrate nonlinear or abrupt responses to perturbation (Scheffer *et al.* 2005; Megrey *et al.* 2009). Management of a fishery ecosystem will require an understanding of the structure and functioning of these systems and their variability (Megrey *et al.* 2009). Additionally, knowledge on how they respond to perturbations and to what extent they are connected or even reliant on other ecosystems will be essential to manage fisheries production (Megrey *et al.* 2009).

## 7.2 SCIENTIFIC UNCERTAINTY ASSOCIATED WITH ANNUAL PREDICTIONS: THE TAC MACHINE

To answer questions such as “What is the optimal catch?” or “How productive is a fish stock?”, fisheries scientists use various mathematical models. These models have usually focussed on a single stock (which is a common feature of fisheries research in temperate climate zones) and hence predict the population dynamics of one stock at a time (Hauge 2002). One of such models still in use today is the virtual population analysis (VPA). An age-based model which predicts the quantity of fish of each age class under various levels of fishing pressure on the response (Kelly & Codling 2006). The population dynamics can be formulated as the stock at a future time ( $S_t$ ) equals the present stock ( $S_0$ ) plus increase due to new recruits (R) and somatic growth (G), minus deaths of natural causes (M) and fishing (F) (Ricker 1975):

$$S_t = S_0 + R + G - M - F$$

---

<sup>2</sup> Mankind benefits from a multitude of resources and processes that are supplied by natural ecosystems. Collectively, these benefits are known as ecosystem services and include products like clean drinking water, decomposition of waste, seafood, transport climate/weather, tourism and so on.

However, the calculations for this model are based on several assumptions:

- Recruitment to the exploitable part of the stock is fairly constant for years,
- Total fishing effort remains steady, and
- Fishing mortality is constant across all ages (Hauge 2002; Kelly & Codling 2006).

Although scientists knew that none of these terms were constant (Rice 2011), those simplifications were usually required by the restrictions of the analytical tools and information available. Another problem associated with these models is the large amount of data they require. For example, in a VPA model, stock characteristics such as population numbers, stock weights, relative exploitation levels, natural mortality and maturity are required for each age class in the population. Additional data on recruitment history and historical catch rates are also requested (Kelly & Codling 2006). However, the more data required in the assessment models, the more sensitive the predictions will be to missing or unreliable data (Punt 1997, Kelly & Codling 2006). For most species these large amounts of data are simply not available, or due to a combination of low abundance and lack of stakeholder engagement stocks have become data-poor (e.g. North Sea and Irish Sea cod). In response to the demand of the EC to formulate a quantitative advice for all fish stocks, ICES has set up a uniform approach which categorises all fish stocks by the data available. For each category specific recommendations are proposed to assess the status of the stock and recommend the allowable catch (ICES 2012a, d).

Despite these latest developments scientific advice will always be faced with uncertainties, either due to the complexity of the system, e.g. assessing the impact of climate change is a good example, or due to the assumptions adopted throughout the analysis which may be uncertain or too narrow (Rice *et al.* 2010; Fulton *et al.* 2011; Rice 2011; Laugen *et al.* 2014). This means that a single, clear scientific answer will never be available for complex systems such as fisheries (Dankel *et al.* 2012). Although we will discuss this in greater detail in Chapter 4, in the end, the success of scientific advice will depend on strengthening the links between environmental science, physical and biological oceanography, fisheries science, and socio-economic sciences, and in developing integrated programs (Dankel *et al.* 2012).

## 7.3 THE POLICY AND SCIENCE MISMATCH

To overcome the “tragedy of the commons” ideally an institution like a government, which is not driven by self-interest, is required. This is especially the case when there are many resource users (Ostrom 2009; Gutierrez *et al.* 2011). International agreements aim at orienting national governments and their actors towards behaviour that can solve the common problems and challenges (see 5.1). The increased scientific knowledge on environmental issues, ecosystems functioning and fisheries resources has promoted an international commitment to more responsible fisheries in an ecosystem context. Nevertheless, in order to be effective to tackle this challenge and solve the problem which is at stake, international regimes rely on compliance (Bernstein & Cashore 2000). Compliance refers to a situation where both the state (as formal member of a regime) and its actors (corporations, civil society organizations, individuals, etc.) conform with the behaviours prescribed by international commitments and the derived national instruments (behavioural effectiveness (Vogler 2000; Ferraro 2010). On its turn, compliance requires completed and successful implementation of rules and laws. International provisions need to be incorporated by states into their national legislation and be applied and enforced in areas that follow under national jurisdiction. There can be no regime effectiveness without state compliance, and no compliance without a smooth process of domestic implementation (Ferraro 2010). As many developing countries experience failures in the implementation of international fisheries agreements independently from each other, this suggests that there are some underlying common processes (following Brans’ argument on large scale local government reform 1992).

Any reform initiative proposed by the international regimes can generate resistance/conflict by several actors. May (2003) addresses the range of pressures coming from political elites (at the national, regional and local level), implementing agencies, economic interests, beneficiaries, and so on. These conflicts will be stronger in the presence of a higher order of change (i.e. in policy goals rather than policy means), because it determines a higher adaptational pressure. Regulatory policies, such as applied in the fisheries sector, are expected to lead to conflicts with the targeted groups, because the visibility of the benefits the reform represents are low, while the costs are deeply felt by the target group<sup>3</sup> (Birkland 2001).

---

<sup>3</sup> In general terms, regulatory policies produce benefits with low or moderate visibility and costs that are deeply felt by the target group (Birkland 2001). In case the benefits of a policy are evident for one group and its costs are spread throughout a large group, then the benefiting group will mobilize to ease the enactment of that policy. By contrast, when costs of a policy are visible to a specific group, it will oppose the policy.

The way conflicts can be overcome or tend not to arise is when an adequate amount of resources is available. This is one of the main limits in developing countries, the scarcity of resources in terms of money, capable manpower, data and information (Ferraro 2010). Therefore, constraints in resources will ultimately have a negative impact on the implementation of international rules (i.e. dependent variable), country's compliance with international regimes, and international regimes' effectiveness for the solution of specific policy problems.

The relevance of institutional incompatibilities and the resulting adaptational pressure suggest that policies can hardly be changed through full innovation: "reform is typically incremental, piecemeal, and by definition slow" (Ferraro 2010; Rice 2011). However, this would imply that time is a pivotal resource, which in a situation of severe fish stock depletion is not the case. Scientific information and understanding of the ecosystem processes accumulate at a steady pace, however usually leaps behind political proposed reformations (Rice *et al.* 2010; Rice 2011). At the initial implementation of the CFP, science was not actually in a position to provide the harvest advice needed for sustainable exploitation or rebuilding of collapsed stocks. Gradually, science had to expand research surveys, intensify catch-monitoring programs and develop or improve assessment methods. Only in the mid-1980s, science was in a position to provide the advice needed to implement the policies adopted in the late 1970s. In the meantime, scientists continued to obtain better insights into population dynamics and the effects of fishing on the ecosystem (Rice 2011). As a result, by the late 1990s, science and policy were again out of synchrony (Figure 1), with science advisors increasingly arguing that an expanded ecosystem approach was necessary for conservation and sustainable use of marine resources (Rice 2011). Policy made another leap forward in the early part of this decade to address the shortcomings in fisheries management notwithstanding the complexity of ecosystems and incomplete knowledge of them (UNEP 2002). However, the change is abrupt and large enough to address the implications of the best-studies cases. This abruptly places policy well ahead of science, as the gap in knowledge, necessary to support implementation of the EAFM to all species and interaction, may be very large (Rice 2011).

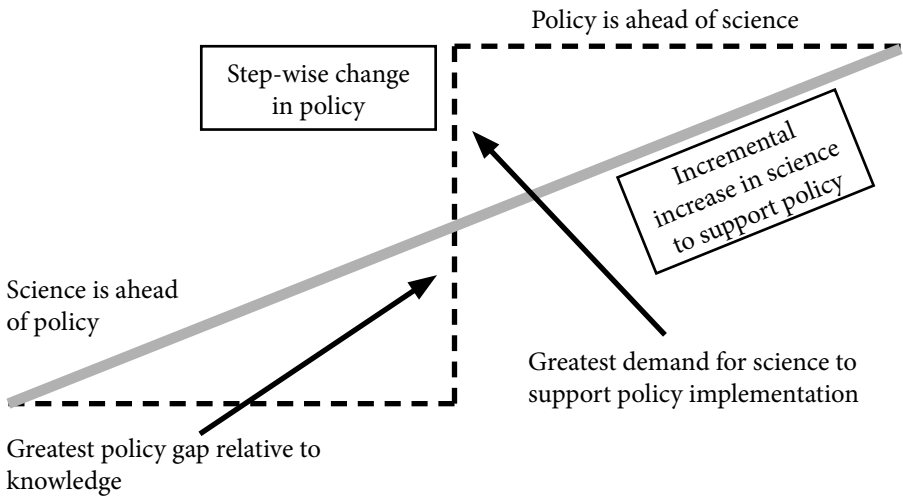

**Figure 1** Schematic picture of the patterns of change in science knowledge and in policy that lead to asynchrony between science support and policy (Rice 2011).

In addition, policy makers are generally required to think in short and medium terms, as well as the longer term. This complexity in policy making requires interdisciplinary solutions which integrate knowledge from a range of areas. The fact that ecosystem processes and responses unfold most of the time over much longer time scales, means that human alteration to an ecosystem often takes centuries before signals are picked up (Hilborn *et al.* 2003a). Nonetheless, policy recognizes the added value of scientific information and the relevance of using scientific information as base for policy decisions, as clearly exemplified in the case of the (reformed) Common Fisheries Policy.

## 7.4 ECONOMIC PERSPECTIVES

Economic growth usually figures on top of the national political agenda. Therefore, the promotion of any other objective which falls outside this core policy priority is easily discarded in practice, even in the presence of rhetorical commitments at the highest political level. Abraham Harold Maslow (1943) explains this human motivation in the field of psychology, as acting according to the principle of the ‘Hierarchy of Needs’ (Ferraro 2010). This means that as long as basic needs for human survival (e.g., food and shelter, security of employment and income) are not fulfilled, the existence of higher levels of needs is not perceived. Maslow includes in the higher levels those needs related to understanding, aesthetic appreciation and spirituality.

Concerns for the environment (such as care for the beauty of nature) are positioned by Maslow (1943) in these higher levels of needs. Looking from this perspective helps us understand why EU policy influences domestic adaptations different in different countries (Héritier 2001).

The European fisheries policy has clearly shown (see Chapter 5) that a shift in policy priority towards environmental protection has occurred. Fishing activities represent the main source of food and employment for many people in the developing world. The fishing industry contributes to the Gross Domestic Product (GDP) and to wealth creation, because the fishing industry is a base industry that supports economic activity in other sectors of the economy including services (World Bank 2009). In addition, the fishing industry is a disproportionately strong foreign exchange earner in many developing countries. To the extent that the availability of foreign currency constrains economic output, the economic benefits from the sector may be greater than is apparent from the national accounts. However, how much fishing actually contributes to the GDP, will be different in land locked countries or islands. Ultimately, the socio-economic consequences of overfishing (loss of income and employment, decrease of food security and drawback in poverty reduction) are more alarming for those developing countries that heavily depend on fisheries. Due to such economic constraints and social urgencies, some countries continue to promote fishing activities beyond a sustainable level. Unfortunately, this creates a complex vicious circle. It has been observed in studies on ecosystem degradation (Choucri & North 1993), where it is described that poverty is both the cause and the result of environmental degradation. In the fisheries field, poverty leads to overfishing (for lack of alternative livelihoods) but overfishing undermines the sustainability of fisheries resources and, consequently, generates more poverty (World Bank 2009). Also, and this is where the “Tragedy of the Commons” becomes very evident, foreign fishing fleets from “not-so-poor” countries often (over)fish in areas of developing countries. A prime case is the fishery off West-Africa (Pala 2013; Pauly *et al.* 2013).

From a strictly economic point of view, making fisheries economically efficient usually means dramatically reducing the number of fishing boats. Unfortunately this means job reduction. But each crew will catch more fish and at the same time fish stocks will be restored, which again facilitates capture. In that way, one obtains a good sustainable yield over a range of stock sizes. The more fish in the ocean, the less time and the less fuel it takes to catch them. Hence generally, one makes more profit by having more fish than one would have when maximizing the total catch of fish.

This is where maximum economic yield (MEY) and maximum biological yield (MBY)<sup>4</sup> meet (Hilborn et al. 2003a; Dichmont et al. 2010) (Figure 2). Economically healthy fisheries are fundamental to achieving accepted goals for the fisheries sector, such as improved livelihoods, food security, increased exports, and the restoration of fish stocks. It is a key objective of the World Summit on Sustainable Development Plan of Implementation (World Bank 2009). From a pure biological and economic dimension, there is not really a conflict to solve overfishing; the social dimension is where matters get tough. Fisheries are embedded in the community structure. One of the reasons why societies are in trouble is that political pressure to maintain employment in fishing communities has led to the subsidization of fisheries, overcapacity, and a too large fleet (Hilborn *et al.* 2003a; Fulton *et al.* 2011). Hence a sustainable fishery translates in job losses due to decommissioning, which is politically only acceptable if it is compensated for.

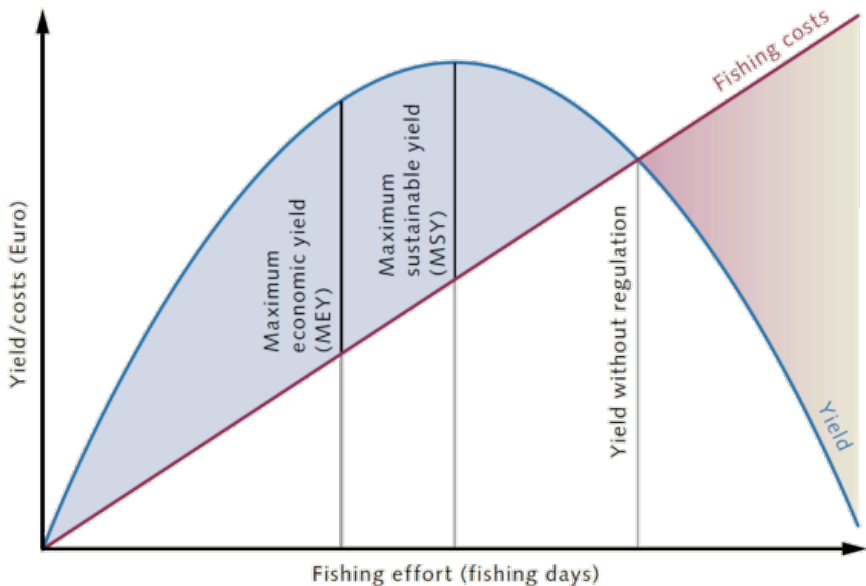

**Figure 2 Profits of fishing (Bollmann *et al.* 2010)**

<sup>4</sup> To what extent is fishing economically profitable in the long term by considering the yield, the operating costs and the fishing effort. A specific constant effort will result in the MSY being achieved. This is the maximum annual catch that can be taken from a species' stock over an indefinite period without jeopardizing that stock. The MEY, by contrast, is a monetary variable. It is equivalent to the maximum annual earnings from fishing, and represents the largest difference between total revenues and total costs. The MEY is attained at a lower level of effort than the MSY. Without regulation, the fishing effort would increase for as long as fishing remained commercially viable, i.e. as long as the earnings obtained from fishing remain positive. In an unregulated fishery, the effort is therefore the point at which revenue and costs are equally high.

However, as stated by Charles (2001), not any amount of research or management of fish stocks is likely to produce a resilient system if humans completely depend on these resources for their livelihoods, and are unable to survive without over-exploiting them. The solution to the absence of livelihood diversity is difficult. In addition, national governments are driven to give priority to short-term socio-economic concerns over the long-term sustainable utilization of fisheries resources. Caddy & Cochrane (2001) highlight that “as long as the decision-makers perceive themselves to be constrained by a lack of alternative options to address short-term human requirements, there can be little hope for sustainable fisheries management”.

### **7.5 CONSERVATION VERSUS SOCIAL OBJECTIVES**

To overcome the problems with world fisheries, a diverse set of policy instruments are proposed by scientists and managers (see 5.5). ITQs for example are largely promoted by economists, community-based approaches primarily by sociologists and area closures predominantly by ecologists (Degnbol *et al.* 2006; Jentoft & Chuenpagdee 2009; Fulton *et al.* 2011). Despite these broad differences in approaches to management options, there is a common format underlying most policy tools, namely the ‘detect and correct’ cycle (Fulton *et al.* 2011). Data on fisheries is collected, analysed and used as the basis for decisions that result in changes in regulations at annual or sometimes longer periods. However until now, regardless of the policy instrument, a consistent outcome is that resource users behave in a manner that is often unintended by the designers of the management system (Fulton *et al.* 2011). Undermining effective fisheries management comes from all kinds of uncertainties which may pop up at each point in the management cycle (Figure 3, Table 1).



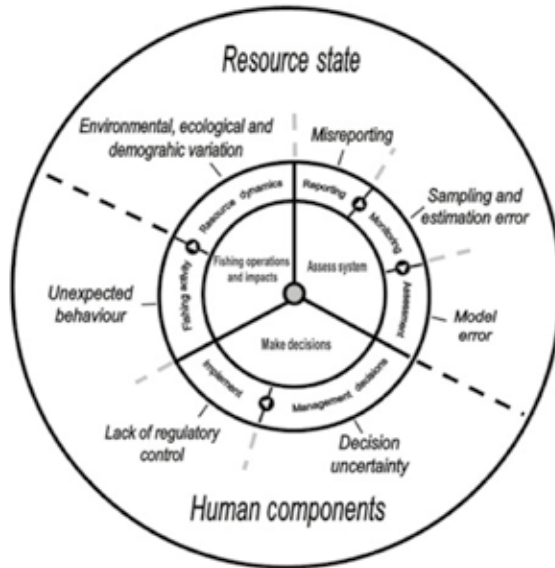

**Figure 3 Management cycle and sources of error or variation that may inhibit successful execution of fisheries management (Fulton *et al.* 2011)**

All actors in a fishery are driven by a mix of long and short-term drivers (Smith *et al.* 1999; Rice & Rochet 2005). For example, fishery managers may be under immediate pressure to produce results. On one hand they should meet up to compromise between long-term social, economic and biophysical objectives such as maximizing resource rents (Rice 2011), while at the same time they have to consider the ecological impact of the fishery and restrict it to acceptable levels (Rice 2011). By contrast, resource users are driven by both short-term profits and long-term considerations such as the status of their investments and the stock they are dependent upon. They want to uphold their community-based social standing and lifestyle choices (Fulton *et al.* 2011). This behaviour of resource users should not come as such a surprise, given their objectives.

**Table 1** Examples of uncertainty associated with different steps in the management cycle (see figure 3) (adopted from (Fulton *et al.* 2011)).

Management step	Example of uncertainty	Example references
Resource dynamics	Recruitment variability from year to year; environmental, genetic and multispecies interactions may lead to strong variation in the number of surviving larvae	Abella <i>et al.</i> (2008); D'Onghia <i>et al.</i> (2012)
Reporting	Misreporting catches; regulatory constraints versus economic incentives may lead to fishermen to fish either illegally or not report the catch (contributing to one-fifth of the global catch)	Nielsen <i>et al.</i> (2012); Agnew <i>et al.</i> (2009)
Monitoring	Shifting baseline syndrome, where generation after generation scientists accept natural stocks status at the start of their career as baseline; sampling and process error can never be completely removed from survey designs; statistical methods can help to alleviate but impede understanding of population or system dynamics	Pauly (1995); Köster <i>et al.</i> (2003); Cordue (2007)
Assessment	Model errors come primarily in two forms, parametric and structural. The former is due to inaccurate parameter values and the latter is when the process assumptions or interactions specified in the model are inappropriate; statistical approaches have evolved to greater complexity such that their proper use is limited to a handful of experts with fewer people able to understand and interpret the results	Mace (1997); ICES (2012); Hilborn (2011)
Management decisions	Political pressure may result in the denial of scientific advice by management bodies, for example quota restrictions may not be implemented (e.g. for a long time TAC settings in the EU has a considerable socio-political component that often restricted the scientific advice implemented in the final decision)	Fulton <i>et al.</i> (2011)
Implementation	International agreements only affect national policies if the authorities are willing and capable of incorporating international obligations into their national legislations and ensure enforcement	Churchill & Owen (2010); Brans & Ferraro (2012)
Fishing activity	Economic, social and cultural drivers can cause fishers to act in unexpected ways, which can undermine the intent of management actions	Fulton <i>et al.</i> (2011)

In most cases, scientific advice for fisheries management concerns the status of the resources. The various sources of uncertainty and error shown in the top half of Figure 3 have all been responsible for poor scientific advice and in some cases they significantly contributed to poor management (Fulton *et al.* 2011). Enormous efforts have been made to reduce the uncertainty in resource dynamics (Hilborn & Walters 1992; Punt & Hilborn 1997).

However, better fishery management outcomes have not always been the outcome (Fulton *et al.* 2011; Dankel *et al.* 2012). An important cause of uncertainty in the adaptive management cycle needs to be accounted for, the human behavioral component of the cycle (bottom of Figure 3). It has become clear that if we want to address unexpected outcomes of management we firstly have to accurately predict behavioral responses.

## 7.6 MOVING FORWARD

As stated in Fulton *et al.* (2011) unintended management outcomes may arise from: (i) decisions where scientific advice on stock status is neglected (Schwach *et al.* 2007), often due to social considerations and sometimes due to political intervention; (ii) lack of regulatory control, most often due to inadequate enforcement and (iii) unexpected behavioural responses of resource users. The ‘band-aid’ approach to management by incorporating marginal changes is a result of decisions made by regulators to try and close loopholes and patch up unforeseen problems arising from the last management intervention (Hilborn *et al.* 2004; Suuronen & Sardà 2007; Grafton *et al.* 2008). Over the past 20 years, an improved understanding of resource uncertainty has been gained by, for example, increasing effort to monitor the resource state and enhance assessment methods (Hilborn *et al.* 2003a; Fulton *et al.* 2011). However, it has become increasingly clear that the unexpected management outcomes are the result of human behaviour related to uncertainty. To address and reduce the implementation uncertainty, managers will have to incorporate information about resource user behaviour beyond the mainly economic objectives that have been included to date. To make this change possible the communication between research disciplines and end-users will have to increase at every step of the management life cycle (Figure 3). We would like to emphasize that interdisciplinary communication has also to improve between scientists, as delivering science is the first, crucial part of fisheries management. Buanes & Jentoft (2009) and Symes & Hoefnagel (2010) argue that scientists in general are stuck in disciplinary silos and speak different languages, often accusing the others, particularly the social sciences, of being ‘fuzzy’ and inaccessible (Fulton *et al.* 2011). We will elaborate further on this, focusing on the use of genetic resources, in the general discussion of the thesis.

In the past, single factor solutions have been proposed all too frequently. However, increasing evidence shows that individually each is bound to fail. Moreover applying the ‘band-aid’ approach to management by sequentially combining different policy tools to fill gaps and loopholes, leads to management complexity and is also unlikely to achieve stated aims (Worm *et al.* 2009; Fulton *et al.* 2011). Most likely, integrated management will involve the use of a range of policy tools, as they have to be robust to behavioral and implementation uncertainty. By increasing our understanding of the link between specific behavioral motivations and the different management tools we will be able to optimize the policy mix for a system - recognizing that the mix will be different for different systems and that even for a single system the mix will have to change as the social, economic and ecological components of the system change (Fulton *et al.* 2011; Gutierrez *et al.* 2011). World-wide researchers have discovered that a common feature to successful management involves stakeholder participation (Ostrom 2009; Fulton *et al.* 2011; Gutierrez *et al.* 2011; Kraak *et al.* 2012). Policymakers should mobilize the best available knowledge in order to successfully tackle problems. This was described by Robert Hoppe (1999) as the ‘making sense together’ model. The increased merit of stakeholder involvements upholds for both community driven rights-based fisheries (e.g., the traditional fisheries of the Western Pacific (Ruddle 1996), or those subject to more top-down institutional governance arrangements. A very interesting example of the ‘making sense together’ approach to fisheries management is presented in Kraak *et al.* (2012) where solutions are presented to cope with unintended user behaviour:

- Non-anonymity - fishers’ individual choices should be publicly known among them and/or within their wider social community;
- Provision of knowledge to fishers on the state of the resource and on the urgency and impact of their responsible behaviour;
- Fishers’ self-decision on rules and (levels of) economic sanctions; and
- Face-to-face communication among fishers and between fishers, managers, and other stakeholders.

Although we have mainly focused on uncertainties resulting from fisher behaviour, the behaviour of other actors also impacts management outcomes (Smith *et al.* 1999). Managers may have incentives to maintain the status quo, and may be more risk averse than fishers when it comes to innovation. Non-government organizations can be driven by demands for on-going funding that has them focus on charismatic rather than ecologically important species, and may find it hard to break away from past confrontational strategies (Whelan 2005).

Scientists can be motivated by reputation, unwillingness to admit error, and political (or funding) pressure to modify or even withhold advice (Daw & Gray 2005; Fulton *et al.* 2011). We have to be aware that all fisheries are managed in the face of uncertainty, yet most of the focus on uncertainty and its consequences has been on the fish rather than the fishers (or other actors) (Allen & McGlade 1987; Fulton *et al.* 2011; Dankel *et al.* 2012). The only way forward to sustainable fisheries, is when fishery managers and scientists pay much more attention to the motivation and behaviour of all the human actors in the system but especially resource users.





# Chapter 8

## The role of science

Foto: © Kevin Vanhalst





# Chapter 8

## The role of science

Chapter 5 has stressed that, for the last two decades, international agreements and organizations have promoted the policy goal of sustainable use of fisheries resources. This resulted in a focus shift from exploitation to the responsible use of fisheries resources. This shift towards responsible exploitation coincides with an increase in the scientific knowledge available at the time that the four treaties (UNCLOS, UNCED, FAO CCRF and JPOI) were issued. The complexity of the ecosystem, due to the multiple interactions between organisms and their environment, has shown that scientific knowledge will be a key starting point for institutional success. As there is often a lack of data, and no time for experiments, and as ecosystems are not fully understood to satisfy policy demands, the interaction between science and decision makers will be crucial. Moreover, most ecosystems are affected by human activity, which implies a role for policy-related knowledge as ecological understanding itself will not be sufficient to answer such human centered questions (see 7.5). As a result there is a need, not only for more sound science, but also for specific and other knowledge related to specific practicalities, and for procedures to deal with uncertainties.

Scientific institutions may contribute to problem solving by guiding (inter)national governmental policy responses to environmental degradation. The ecological effectiveness then depends on the responses of the actors and policy-makers. According to Rotmans & Van Asselt (1996), scientists provide information on what is plausible and possible in the light of scientific knowledge and technical expertise. On the other hand, decision-makers and societal stakeholders determine what is legitimate and desirable on the basis of the interests and values present in the socio-economic fabric.

## 8.1 KNOWLEDGE PRODUCTION AND UTILIZATION

Within a decision-making process, one cannot assume that a certain process works well or not on a hunch. Nor can any environmental, social or political problem be addressed on the basis of a personal belief. At the same time, no process can be excluded on *a priori* grounds, as all arguments have to be turned into a rigorous procedure. It is for this reason that the need for science becomes most obvious. The scientific method is based on experimental hypothesis testing, rigorous data analysis and reproducible results. The quality of science or the “credibility” is assured by the review process by academic peers and the publication in peer-reviewed journals (McNie 2007; Wilson 2009; Holmes & Lock 2010). This route of knowledge production assures that science presents a clear body of evidence and represents something free of personal value judgments (McNie 2007; Wilson 2009). However, due to the complexity of the environment, science might never understand the ecosystem fully. It implies that a single scientific answer will never be available for complex systems such as fisheries (Kraak *et al.* 2010; Dankel *et al.* 2012). Populations and fishery dynamics, as well as stock assessments and management, are characterized by both environmental and human-induced variability and uncertainty, not all of which is or can be incorporated into scientific simulation models and assessments (see chapter 7). For example, although processes like temperature fluctuations and diseases influence natural mortality, it was recognized that fishing pressure over a long time period is the pivotal variable explaining fish stock dynamics (Cardinale & Svedäng 2004; Gislason *et al.* 2010). Even data collection itself is subjected to stochastic variability, known as sampling error (ICES 2013). Other sources of variability like the practice of high-grading, discarding and the high level of Illegal, Unreported and Unregulated (IUU) fishing will affect fishing dynamics estimated from age-reading data as the stocks are dominated by younger year-classes (Poos *et al.* 2010; Österblom *et al.* 2011). These variability’s make quantitative stock assessments very difficult and increase the uncertainty around forecasts (Daw & Gray 2005; Österblom *et al.* 2011). Traditionally, scientists want to reduce this uncertainty by expanding research, as they use uncertainty both to obtain funding and to develop interesting research questions exactly in this area of uncertainty (Wilson 2009; Petersen *et al.* 2011). Dealing with uncertainty in this manner, assumes that uncertainty is merely a shortcoming of the currently available knowledge and performing more research will solve this temporary problem (van der Sluijs *et al.* 2008; Petersen *et al.* 2011). However, scientists are often blamed for producing too much of the wrong kind of information (Cash *et al.* 2003).

As stated by Rice “science often present their calls for policy change from the perspective of their favorite part of the ecosystem, rather than the perspective of governance and societal consequences, which are essential consideration to policy analysts” (Browman & Stergiou 2005; Cordier *et al.* 2011). To conduct more research, that is regarded relevant for both policy-makers and stakeholders (“salience”), requires that the connection between both the supply of, and demand for, scientific information is enhanced (McNie 2007; Lang *et al.* 2012; Kraak *et al.* 2013). Whereas research institutes and universities are often blamed to put too much weight to scientific credibility at the expense of the relevance and utility of the research, taking up partnership with the fishing industry will undoubtedly lead to a better balance between research that is regarded salient, credible and legitimate (perceive to be unbiased and fair) (Lang *et al.* 2012). Furthermore, the principles of a precautionary approach to management decisions requires that we also take into account socio-economic considerations (De Santo 2010; Österblom *et al.* 2011). This was acknowledged through the establishment of Regional Advisory Councils (RACs) with the 2002 ‘revised’ CFP (European Communities) and demonstrated in e.g. two EU-funded projects (GAP1 and 2<sup>1</sup>) aiming to demonstrate the role and value of stakeholder driven science within the context of fisheries governance.

In addition, the precautionary approach to management and the EAFM induce that the lack of certainty should not be a reason for hesitation or inaction (De Santo 2010). Effective approaches to deal with scientific uncertainty are proposed through concepts like “post-normal science” (PNS), mode-2, triple helix and other science paradigms (Funtowicz & Ravetz 1993; Gibbons *et al.* 1994; Etzkowitz & Leydesdorff 2000) that employ corresponding research practices, such as transdisciplinary, community-based, interactive, or participatory approaches (Lang *et al.* 2012, and references therein). Regardless of the underlying theory, all these concepts have one similarity: the need to focus on research collaboration between scientists from different disciplines and non-academic stakeholders. Consequently, one should look at these practices as a complementary approach to conventional science approaches (i.e. statistical analyses). For example, the concept of PNS suggests that in situations of high uncertainty and high stakes, imperfect (and sometimes subjective) knowledge has to be used in providing advice to policymakers. Apart from testing knowledge for validity and reliability, it should be tested for “social robustness” (Van Der Windt & Swart 2008) by the inclusion of an extended peer community (EPC), including both scientists and stakeholders with complementary expertise (Funtowicz & Ravetz 1993; Petersen *et al.* 2011; Dankel *et al.* 2012).

---

1 More information on both project can be found on the project website [www.Gap2.eu](http://www.Gap2.eu)

The knowledge production as such is organized in a way that it increases social robustness and guarantees scientific quality at the same time (Petersen *et al.* 2011). Utilizing such a problem- and solution orientated approach, allows first to identify problems, and focus on understanding them (Watson 2005; McNie 2007; Lang *et al.* 2012). By first involving stakeholders and communicating with policy-makers, the most appropriate and useful scientific information can be generated and supplied (McNie 2007; Österblom *et al.* 2011; Lang *et al.* 2012). Secondly, the use of the EPC enables scientists to identify several policy choices regardless of uncertainty. Afterwards these policy choices should be implemented.

To summarize, simply monitoring a species, or a single ecosystem parameter, does not provide sufficient information for policy-makers to understand the relationship between the drivers of ecosystem change and a particular observation at some point in time (Watson 2005). Utilizing a problem-driven and solution-oriented approach offers several advantage as it aims at bridging the gap between problem solving and scientific innovation. At the same time this does not undermine the relevance of disciplinary or interdisciplinary approaches (McNie 2007; Lang *et al.* 2012). How this positively affects mutual trust and leaning between policy-makers, stakeholders and scientist, will be discussed in the following section.

## **8.2 COMPLIANCE THROUGH STAKEHOLDER PARTICIPATION**

Useful scientific information should improve environmental decision-making by expanding alternatives, clarifying choice and enabling decision makers to achieve desired outcomes (McNie 2007). Therefore, useful information is required which is not only regarded as credible in the eyes of scientists, it has to be perceived by the users to be accurate, valid, and of high quality (McNie 2007; Petersen *et al.* 2011; Dankel *et al.* 2012). While peer review is often considered an essential prerequisite of credible information, other approaches also satisfy the credibility criterion, for example, through government or industry sponsored-research and/or collaborative projects between several actors (McNie 2007; Österblom *et al.* 2011). Additionally, collaborative research projects may generate important new insights as local knowledge is incorporated and ecosystem developments are detected in real-time (Österblom *et al.* 2011; Phillipson *et al.* 2012). At the same time, this cooperation is important to generate trust and increase ownership of ecosystem problems and solutions (Holmes & Lock 2010; Fulton *et al.* 2011; Österblom *et al.* 2011; Lang *et al.* 2012).

Increased trust and respect among scientists and stakeholders increases the legitimacy of scientific advice (Österblom *et al.* 2011), as trust can be acquired through transparency (GAP 1 & 2). Besides summarizing the behaviour and actions essential for successful participatory research, they provide an overview of a step-by step guide annotated with different factors that should be taken into consideration during stakeholder engagement process (Mackinson *et al.* 2011).

Transparency in knowledge communication can be fed back to the communication of scientific uncertainty. Although overemphasizing uncertainty in fisheries advice may lead to policy paralysis (Rosenberg 2007; Dankel *et al.* 2012), experience in science and policy debates have shown that underemphasizing uncertainty is even more dangerous, because it may cause lasting damage to the credibility of the science (van der Sluijs *et al.* 2008; Petersen *et al.* 2011; Dankel *et al.* 2012). In such cases scientist may be tempted by advocacy science (Rice 2011). Here, information is used that “strengthens” the conservation case selectively (Nelson & Vucetich 2009; Rice 2011). However, Rice (2011) warns for the consequences of giving in to such temptations. Science will lose its objectivity as it is biased of those who provide it, rather than reflecting the information on which the advice is based (Rice 2011). Ultimately, everyone loses, including the ecosystem (Rice 2011). In contrast, the impact of science advice on decision-making should be increased by peer review by diverse experts (Funtowicz *et al.* 1999; Petersen *et al.* 2011), by integrating advice on ecological, economic and social information and outcomes (Ostrom 2009) and by focusing advisory approaches on risks, costs and trade-offs of different types of management proposals (Watson 2005; Rice 2011). In nations like the USA, Canada and Norway a high degree of stakeholder participation in consultation and decision-making have illustrated that legitimacy is indeed facilitated and all decisions are backed up by transparent advice (Österblom *et al.* 2011). Ultimately, it results in a high level of compliance with the overall policy-making process, accompanied by providing the industry with long-term perspectives and potential future pay-off from restrictive management (Österblom *et al.* 2011). In the last few years, more countries implement the above mentioned conditions by increasingly using effort restriction tools with transferable quotas. Furthermore, the use of certification schemes, encouraged by managing authorities, can provide incentives to comply with regulations (Österblom *et al.* 2011), and there is an ongoing development of methodologies for tracking products throughout the entire supply chain, from landings through sales, processing, transportation and marketing (Ogden 2008; Nielsen *et al.* 2012). The latter being important to control whether management restriction are followed (Fulton *et al.* 2011; Gutierrez *et al.* 2011).

### 8.3 BOUNDARY ORGANIZATION AS THE COMMUNICATOR, MEDIATOR AND TRANSLATOR OF SCIENTIFIC INFORMATION

The amount of interaction between scientists, policy-makers and stakeholders is according to Pielke (2007) depending on the policy problem. In his work on the Honest Broker, Pielke states that experts choose how they relate to decision-makers. From a decision-maker point of view the amount of interaction shapes their ability to use expert advice in a particular situation, but also shapes the legitimacy, authority and sustainability of expertise itself. Crucial to this, regardless of the choice, is that scientists should aim for transparency through good communication (Swart & Van Anandel 2008). Lack of open-mindedness, strong prejudices and an inability to compromise may represent devastating barriers to initiating participatory research. Van Der Windt & Swart (2008) describe that co-production of knowledge requires “the ability and willingness of each party, scientific and non-scientific, to cope with the knowledge and demands of the other parties and respect opposing interpretations. At the same time, a certain common ground and cohesion is needed to bind several actors and their perspectives to rise above pluriformity”. Boundary organization may play a crucial role in science-policy interaction. Not only because they play a part in the interpretation and translation of the different experienced worlds (Van Der Windt & Swart 2008), but also because they facilitate the reconciliation of the supply and demand of scientific information (McNie 2007). In other words, boundary organization links both scientific and non-scientific parties, which enables them to communicate, mediate, and translate knowledge (Ostrom 2009; Holmes & Lock 2010; Österblom *et al.* 2011), while at the same time they are flexible enough to maintain and legitimize their own interpretations or practices (Van Der Windt & Swart 2008). National fisheries institutes (NFI) lend themselves perfectly to this task (Holmes & Lock 2010). First, NFIs communicate through annual meetings with the ministry responsible for fisheries management (Holmes & Lock 2010). Such meetings are used not only to inform fisheries management with data as input to international negotiations on fishing quotas, but also to discuss about multi-year strategies, plans or agreements. Additionally, policy-makers could indicate priorities for future research needs and advice. The uptake of the priorities in research proposals will depend on the institutes staff whether they are involved in both research and advisory activities (McNie 2007; Holmes & Lock 2010; Kraak *et al.* 2013). According to Holmes & Lock (2010) the ability of the institute’s staff to identify research needs derives in part from their day-to-day interaction with staff in the ministry, and their involvement in international working groups.

The daily interaction builds long-standing relationship between the NFI staff and fisheries managers creating a high level of trust and familiarity, which in turn gives managers the confidence to delegate research questions. The involvement of scientists in international working groups provides them with the network to communicate research needs and conduct research in a multidisciplinary way.

Regardless of the above-mentioned, another deficit which limits the uptake of scientific research is related to the rather limited scientific capacity in-house of ministries. Hence their ability to interpret research results, identify research needs is limited (Holmes & Lock 2010). It is important for scientists to be aware of this shortcoming, as they are used to report research results in detailed technical reports. However, policy-makers are typically more interested in short summaries of research results which provides them an interpretation of the research suitable for policy. Although such detailed reports and papers in peer reviewed journals are a requisite for the scientist to communicate with a scientific audience and to build up their expertise and credibility, they should be aware of the need to present our results in different ways to influence the uptake of research results into policy more efficiently. In summary, national fisheries institutes fulfill the role of boundary organization or “knowledge broker” as they work on the interface between research and policymakers while at the same time communicate with stakeholders and more and more often work in close contact, co-producing knowledge (Österblom *et al.* 2011; Phillipson *et al.* 2012; Kraak *et al.* 2013). Such joint working atmosphere has been identified as important in avoiding knowledge battles. Similarly, it helps to science to be salient, credible and legitimate. In the general discussion we will use this framework specifically in the communication of genetic results into fisheries management of flatfish. Communication between university, NFI and scientist from the ICES working group will play a crucial role in the uptake and the credibility.





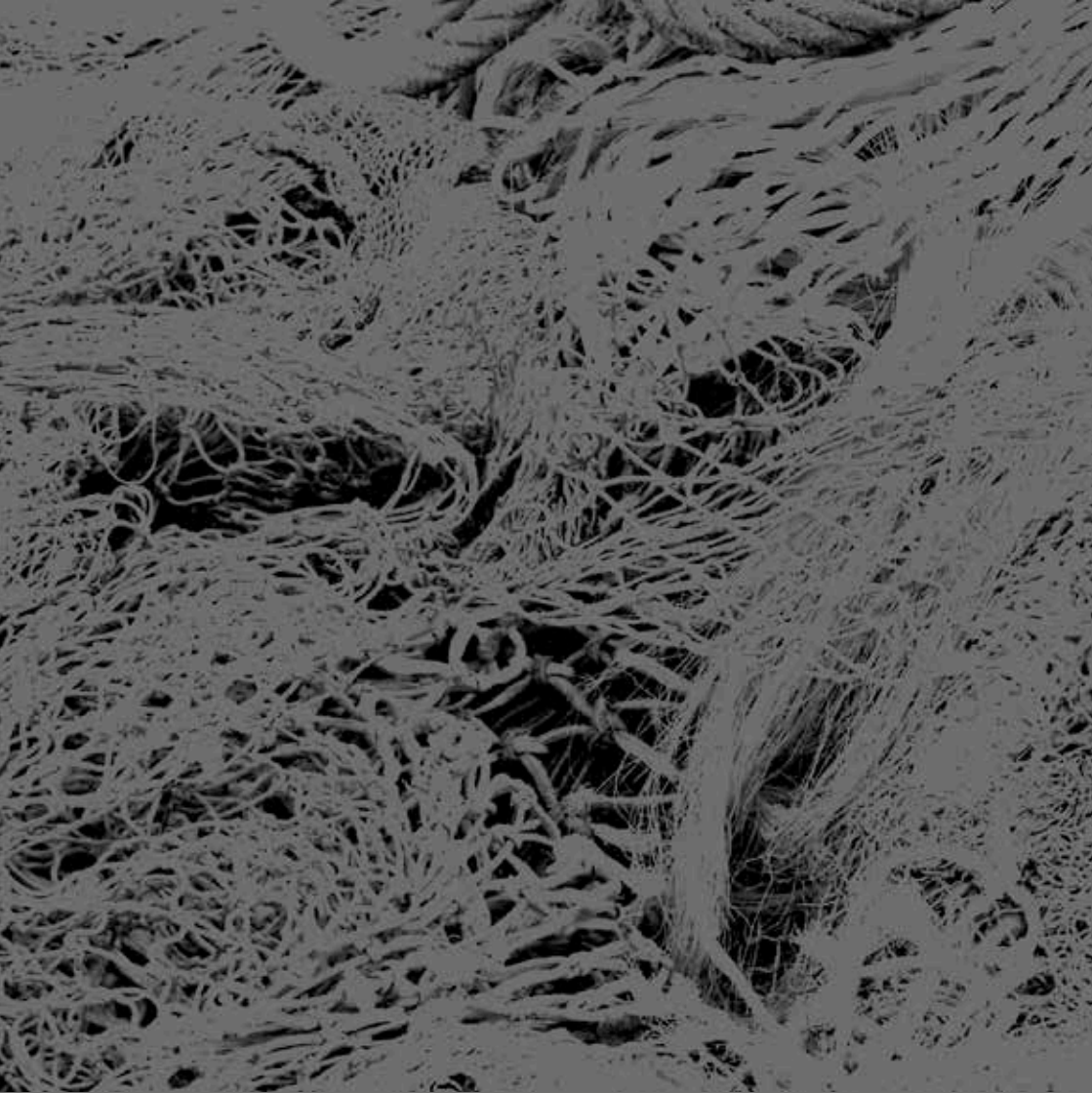

# Chapter 9

## General discussion

Foto: © Hans Hillewaert





# Chapter 9

## General discussion: Diving into the use of genetic tools for fisheries management

To achieve a sustainable management and use of the seas and oceans is one of the great challenges of today. Over the years, the breadth of issues considered by fisheries managers has increased dramatically so that, in addition to conventional management problems, issues such as ecosystem effects of fishing and efficient analytical tools to control for compliance and enforcement of the rules of the Common Fisheries Policy (CFP) are needed (see 5.5, COM 163 2009; Fulton *et al.* 2011; Kraak 2011). At the EU level, the policy landscape for marine and maritime affairs has advanced considerably with the adaptation of the Integrated Maritime Policy (IMP) in 2007 (see Chapter 5). On May 30<sup>th</sup> 2013, the EU Council of Ministers and Parliament reached a landmark agreement paving the way for a reformed CFP set to come into effect on 01 January 2014 (see Chapter 6). The overarching aim of this reformed policy is to end overfishing and make fishing sustainable through implementation of an ecosystem based approach to management (COM 163 2009; Rice *et al.* 2010; European Marine Board 2013). This places an onus on policy makers who, despite their obligation to take scientific advice into account (European Communities 2002, art. 33), they will have to be even more proactive in seeking and utilizing scientific input in their decision making. At the same time, scientists have to be more proactive in engaging with policy makers and seeking to transfer scientific knowledge to meet societal needs (Rice *et al.* 2010; European Marine Board 2013).

Similarly, genetics has experienced a revolution largely driven by technological progress in high-throughput sequencing and theoretical progress in the analysis of genetic data. In light of these changes in both the scope of management and scientific capability, there is a need to reassess the ways in which genetic research may contribute to fisheries. Fishery managers and researchers, industry representatives and fisheries geneticists need to be aware of each other's focus and capabilities in order to make the most of new genetic technologies.

This discussion therefore includes a review of how genetic tools can be used to assist the management of marine fisheries. Additionally, I combined the knowledge produced in this doctoral thesis on both fisheries management and fisheries genetics to make suggestions for the sustainable harvest of flatfish. I discuss the strength and weaknesses of the methodology and how this can be dealt with in practical fisheries management.

## **1 THE GENETIC TOOLBOX FOR FISHERIES MANAGEMENT**

Genetic data can and has been applied to address questions of immediate relevance to fisheries management (Wennevik *et al.* 2008; Waples & Naish 2009; Dann *et al.* 2013). These applications include:

1) Monitoring of biodiversity (among and within species),

2) Identification of biologically relevant management units and identification of origin of individuals and mixed samples ('genetic stock identification' GSI and 'mixed-stock analysis' MSA).

Assessing the distribution of genetic variation may be used to divide the range of harvested species into biologically relevant units suitable for independent management. MSA is a method, based on the identification of such units, to determine statistically the contribution of independent breeding stocks to a mixed exploited population. As such, MSA and GSI can be used to determine the exploitation rates of individual populations and management units,

3) Product provenance and fisheries surveillance.

Genetic analysis is a useful tool to support regulation, enforcement and surveillance. Given appropriate reference material, specimens may be assigned to species, population, family group or individual,

4) Fisheries-induced and natural selection.

Two issues are addressed here: the potential for harvest to increase the frequency of undesirable traits in harvested species and the use of genetic tools to identify adaptation to specific environmental conditions,

5) Environmental monitoring.

Genetics can provide ways to monitor the complex interactions between fisheries and the environment, such as food web analysis, remote detection of invasive species, and monitoring for environmental contaminants,

6) Detection of stock sex- and age ratios.

Preliminary research suggests telomeric DNA has potential to estimate age, which would be a step forward for species that cannot be aged by conventional methods,

7) Genetic effective population size.

Estimates of genetic effective population size can be used to index changes in abundance through time, including prior to industrial fishing,

8) Monitoring the presence of escapees from aquaculture, and their interaction with wild stocks.

Interbreeding with captive-bred fish may change the genetic attributes of a wild population, potentially affecting their fitness and viability,

9) Genetic mark-recapture for estimating mortality and abundance.

Novel genetic mark-recapture methods can directly estimate critical parameters in fished or by-catch species such as mortality, abundance and movement.

For the time being, some of these applications are more readily available outside an academic environment than others. The scope of this discussion is not to provide a review of applications and is far from exhaustive. These and other genetic applications for marine fisheries management have been discussed in great detail in recent reviews, reports and books (e.g. Hauser & Seeb 2008; Waples *et al.* 2008; Cadrin *et al.* 2013). Nevertheless, this overview represents a diverse collection of methods that yield useful biological information for fisheries management. In some cases, the genetic analysis could support several management issues, as genetic data could be easily collected in one project to address for example, product provenance and fisheries surveillance, species recognition and MSA. However, the way in which genetic questions are combined and deployed in practice will depend on many factors including the type of genetic data needed, details of the management challenges and consultation between stakeholders and geneticists (Dichmont *et al.* 2012). Several examples illustrate molecular techniques are already employed to support fisheries management and to provide evidence in court. For example in the Genetic stock identification of Atlantic salmon (ICES 2012b), in the management of Norwegian coastal cod (Wennevik *et al.* 2008; ICES 2012b), or in a court case where a Belgian fisherman was convicted by DNA test (Martinsohn 2011).

Cases like the later shows that advanced techniques, such as genetic marker analysis, are used for control and enforcement in the European fisheries sector and that evidence provided by these techniques is admitted in court trials in EU member countries. More importantly, it also shows that advanced techniques cannot only be used efficiently for species identification but in addition for the more challenging question of origin assignment (Martinsohn & Ogden 2008; Ogden 2008; Nielsen *et al.* 2012).

### 1.1 Barriers to uptake for fisheries management

Currently, the routine use of genetic information in fisheries management remains exceptional, although there is a great deal of genetic information available for many species of interest in relation to both the sustainable exploitation and the maintenance of biodiversity. Despite the acknowledgement by eminent scientific advisory bodies like the International Council for the Exploration of the Sea (ICES) and the Scientific, Technical and Economic Committee for Fisheries (STECF) on the value of genetic data, a range of reasons are responsible for the conspicuous absence of genetics in operational fisheries management (European Commission 2011; ICES 2012b). Some are historical, others arise due to a lack of communication between fish geneticists, fisheries managers and regulators (see below) and others are due to a lack of transdisciplinarity. Also, the current management infrastructure is not conducive to the uptake of genetics. Fish(eries) genetics remain almost exclusively embedded in the academic realm and research projects, with its focus on new developments and lack of a long-term perspective and funding. Researchers, after having concluded a project, move on and have neither the means nor the time to put the results of their studies into an operational context. This was for example highlighted by the project FishPopTrace in the frame of the Seventh Framework Programme (FP7). The JRC partner of the project observed that many, if not most, projects maintain local databases. However without a web interface, they are not accessible. It highlights the pressing need for a shared professionally managed data and genotyping infrastructure, and a routinely structured sample collection (European Commission 2011; Dichmont *et al.* 2012; ICES 2012b; STECF 2012b).

The fragmentation of marine data is not restricted to biological information. The European Commission is aware of this problem and proposed a new European Marine Observation and Data Network (EMODNET) in its Green Paper on maritime policy (COM 163 2009; Martinsohn 2011). The basic principles underlying EMODNET, include the development of standards across disciplines, data validation and quality control, and this through building on existing efforts.

There is no doubt that this initiative is well suited to help resolve the issue of data fragmentation in the maritime sector. Therefore, the incorporation of genetic data relevant to fish species and population structure identification would also support the CFP. In this respect the Data Collection Framework (DCF, European Communities 2008b) and the envisioned new Data Collection Framework Multi Annual Plan (DCF-MAP) 2014-2020 (STECF 2012b) are of importance. The current DCF and new DCF-MAP establish a Community framework for the collection, management and use of data in the fisheries sector in support of scientific advice regarding the CFP (European Communities 2008a, b). While general biological data are referred to under this regulation, molecular data with relevance to fisheries management are currently not actively collected and compiled by any of the EU Member States. The data currently collected under the DCF are first stored in national databases and then transmitted to the end-users, e.g. ICES, to perform scientific analyses. However, it may also be used to support discussions in Regional Advisory Councils (RACs) within the framework of the CFP for policy development and for scientific publications by researchers. Although the RACs were established to deepen stakeholder participation in policy-making (see 5.3.1, Österblom *et al.* 2011), they are also useful arenas to make suggestions and recommendations to the Commission and the competent national authorities regarding the geographical areas they cover. Such recommendations might include for example the need to integrate genetic data sampling into the DCF.

The main effort to use of GSI or MSA in fisheries management, lies in the establishment and maintenance of baseline data that will allow biologically significant inference in space and time. However, once a set of markers is determined that allows assessment on the desired spatial scale, the issue of database maintenance by temporal updates is not different from requirements for other type of data (ICES 2012b). Amongst others, the RACs put forward objectives in long-term management plans and help set specific fisheries targets to achieving sustainable catches (European Communities 2008c; Österblom *et al.* 2011; Kraak *et al.* 2013). As such, these plans could be used to determine conservation priorities for the so called ‘umbrella’ species (the most vulnerable economic species, Lambeck 1997; Nicholson *et al.* 2013). These umbrella species will become the limiting factor for many fisheries and failure to adequately deal with umbrella species will result premature closure of fisheries with the results that some quota may be underutilized<sup>1</sup>.

---

1 In a mixed fisheries, like the demersal fisheries, it is not entirely possible to control which species and how much of each is caught. Under the current management approach, where single-species TACs are largely set without due consideration of this technical artifacts, the TACs some stocks are exceeded in trying to maximize the TACs for other stocks. One approach in making TACs more effective in a mixed-fisheries context is to predict catches of the key species under different scenarios (Ulrich *et al.* 2011). Following the TACs for the most vulnerable species will result in a lot of unused catches for other species.

Besides access to data collected through standardized formats, there are other requirements that have to be fulfilled before genetic analysis could be used as a solid base for routine use under the CFP. Once genetic is used pragmatically, it is no longer regarded as research (although research is needed to set up new monitoring techniques) (Dichmont *et al.* 2012; Bourlat *et al.* 2013). This opens the discussion about where the responsibility lies for monitoring and financing, which is believed to lie with state governments and other jurisdictions (Dichmont *et al.* 2012). Additionally, a network of test laboratories should be set up, certified to carry out analysis for control and enforcement purposes, and sharing information, harmonized and validated protocols, Standard Operating Procedures (SOPs), as well as expertise. This does not necessarily mean that new laboratories have to be created, as most EU member countries do already have facilities with the necessary capacity. However, at present these laboratories work rather in isolation and on an *ad hoc* basis, upon simple request from the authorities. A third crucial component of capacity building is training. This is true both for inspectors working in the field who will have to become familiar with tissue sampling for analyses, and also for laboratory personnel and enforcement officers. Finally, information dissemination activities have to be part of capacity building, so that national authorities know where to go and whom to contact to receive expert advice and to carry out analytical work. A central hub for the EU, endowed with this assignment and liaising among the stakeholders would greatly support such an effort. The Community Fisheries Control Agency (CFCA) might be well positioned to assume this role (Martinsohn 2011).

To move away from the research and academic environment where genetic information on marine fish is usually accommodated, will require an increased awareness of their possibilities through more dialogue on:

- How to take best advantage of genetic information,
- How and where to collect/compile/disseminate genetic data and
- How to finance such an endeavor linking all actors in fisheries management.

In the following section we discuss communication strategies and who is responsible to take action. At the end we'll acknowledge the importance of knowledge brokers as key facilitators in this process, to optimize access to relevant knowledge for decision-making (Michaels 2009; European Marine Board 2013).



## **2 KNOWLEDGE TRANSFER TO INTEGRATE THE GENETIC TOOLBOX IN FISHERIES MANAGEMENT**

One of the main stumbling blocks for the effective use of genetic tools in fisheries management, is poor communication (European Commission 2011; Dichmont *et al.* 2012). Like many specialized scientific disciplines, the science of genetics is highly technical and understanding the basic concepts can be challenging. Resulting from this, genetic research often fails to deliver practical management outcomes, which limits access to the benefits. Nevertheless, the above mentioned examples illustrate that genetics holds great benefits for fisheries management. In the following I'll explain how better and efficient communication between all stakeholders (encompassing policy-makers, scientists and fishermen) can improve the uptake of specialized sciences, such as genetics, in support of achieving the management goals. To this end I'll elaborate on what scale this communication should take place, who's responsible for good communication and what will be required from the actors.

### **2.1 Communication among all stakeholders**

As indicated in Chapters 7.7 and 8, the first and most obvious communication should take place between fisheries managers and scientists (ICES 2008; Holmes & Lock 2010). Policy makers must express their objectives in a clear, quantitative and ranked manner (setting priorities). They must identify which expertise is needed to answer their objectives and how science can be incorporated. At the same time, gaps in current knowledge can be identified, which drives the production of new knowledge (Rice *et al.* 2010; European Marine Board 2013). For most Member States the science-policy interaction happens between the staff of the Ministry responsible for fisheries management and the National Fisheries Institutes (NFI, Chapter 5). The formal responsibility of the NFI includes carrying out research and provision of advice on fisheries management in support of their national government. However, Holmes and Lock (2010) emphasize the need for a certain level of autonomy by the NFI. This can be achieved through the funding for research in the NFIs by EU program. This not only ensures that the NFIs are effective in supporting the relevant fisheries ministry, but also drives the requirement for top quality science.

The knowledge produced in these projects and the established network among NFIs and with the academic realm, can then be applied into practical fisheries management terms at a later stage.

Fisheries managers themselves have too little time to learn about every aspect of the different scientific fields (Dichmont *et al.* 2012), due to the complexity of the marine environment and the broad array of drivers which have to be taken into account. At the same time, it is clear from the lack of knowledge among both managers and stakeholders about the genetics tools (European Commission 2011; Martinsohn 2011; Dichmont *et al.* 2012), that geneticists rarely have direct links with the policy-science interface (e.g. they are rarely members of assessment working groups or management advisory groups). This means that the most effective partnership is likely to be between fisheries scientists and geneticists, where scientists act as a conduit for genetic data via advisory groups to managers.

The fishing industry is an important customer of research and advice, generally in terms of stock assessments, management plans and fishing gear (McNie 2007; Holmes & Lock 2010; Kraak *et al.* 2013). In a more or less formal way, responding to the needs of the fishing industry is part of the role of the research institutes. This co-production of knowledge leads to research that meets both scientific and societal needs and results in a more cost effective implementation of policy (see Chapter 8, Watson 2005; Österblom *et al.* 2011; Lang *et al.* 2012). Whereas science is often blamed to put too much emphasis on scientific credibility and legitimacy (McNie 2007; Lang *et al.* 2012), partnerships with the fishing industry build on the saliency and legitimacy of the science created (Österblom *et al.* 2011; Lang *et al.* 2012). This creates a sense of shared ownership of the results, which further reduces the incentives of the fishers community to undermine fisheries management measures (see 8.2, Hilborn 2007; Fulton *et al.* 2011; Kraak 2011). In conclusion, communication responsibility must be shared by all actors so that the needs of fisheries managers, geneticists, fisheries scientists and stakeholders are better understood (McNie 2007; Petersen *et al.* 2011; Dankel *et al.* 2012).

### **2.2 National Fisheries Institutes serve as knowledge broker**

In the political arena of the supranational EU, communication should take place between all actors both at the national and international level. Ministries are responsible for the development of national strategies and policy for marine fisheries, for national input to EU and international policy development and negotiations, and for national management of EU structural programs for the fishing industry (Holmes & Lock 2010).

The NFIs carry out research and provide advice on fisheries management in support of their national governments. However, this role requires them to represent their countries on international committees and working groups while they also have a broader remit to carry out research on other issues such as ocean science and environment. Traditionally NFIs have long-standing relationships with the ministry responsible for fisheries management, which led to high levels of trust and mutual understanding (see 8.3, Holmes & Lock 2010). These are important factors underpinning the effective communication of evidence needs, advice and research results. While this is a strength, at the same time therein lies a vulnerability, as this communication mainly depends on a small dedicated group of key staff members of the NFI (Holmes & Lock 2010). Nevertheless, the ability of the staff of the NFIs to anticipate future advisory needs often relies on staff being involved in both research and advisory activities (McNie 2007; Holmes & Lock 2010; Kraak *et al.* 2013). Communication between the fishing industry, NFI and policy-makers might be less obvious, still they are involved in fisheries management at many stages. Although it rarely funds research itself, as this might compromise the independence of the NFIs (Holmes & Lock 2010), the general aim is to involve fishermen in co-commissioning research and to build relationships between fishermen and the research community (Petersen *et al.* 2011; Dankel *et al.* 2012). The RACs, being a stakeholder organisation, aim to maintain a dialogue and cooperate in the development and implementation of the CFP. The somewhat ambiguous role in the production of management advice within the revised CFP points out the relevance of communication on the genetic tools and the requirements of their systematic integration in fisheries management (see part 1).

Regardless of the scale at which communication has to happen, the full uptake of all available knowledge into European policy is often hindered by a lack of effective interfaces (Österblom *et al.* 2011; Briggs & Bowen 2012; European Marine Board 2013). The most straightforward way of communicating in a scientific setting is through the generation of written reports and papers. Papers in peer reviewed journals are seen as the prime mechanism for communicating with scientific audiences, along with papers resulting from international working groups and conferences (McNie 2007; Wilson 2009). However, these papers are often very detailed and technical, mainly comprehensible to a specific audience. Fisheries managers are typically interested in short summaries which provide an interpretation of the research for policy (McNie 2007; Holmes & Lock 2010).

On the other hand, articles in magazines and journals read by fishermen are considered to be an effective way of communicating with the fishing industry. Nevertheless, the most effective way of communicating occurs through face-to-face interactions (Van Der Windt & Swart 2008; Holmes & Lock 2010; Dichmont *et al.* 2012). This interaction demands researchers to briefly present their results, which may be discussed among all the present actors. Herein lies its strength as researchers have to explain their research in plain language and focus only on a particular part of their research (Swart & Van Anel 2008; Holmes & Lock 2010; Dichmont *et al.* 2012). The open dialogue which is created requires a two way communication (Swart & Van Anel 2008; Van Der Windt & Swart 2008; Dichmont *et al.* 2012). The ability to listen and ask appropriate questions helps to achieve understanding and respect for the knowledge and views of others (Van Der Windt & Swart 2008). The discussion and debates that might occur at those meetings are useful in the sense that strengths and weaknesses of a certain issue are exposed and subsequently may move science forward (Young 1989; Wilson 2009; Brown *et al.* 2010). At the end of such meeting a consensus has to be reached (Wilson 2009) aiming at solution orientated science with the necessary trade-offs and accommodation for uncertainties (McNie 2007; Lang *et al.* 2012).

Opportunities setting up dialogues among scientists and other actors can be achieved using existing formal processes. Here, boundary organization may play a crucial role (Pielke 2007). On the national level, NFIs fulfill this role as they work on the interface between research and policymakers while at the same time communicate with stakeholders (Holmes & Lock 2010; Österblom *et al.* 2011; Phillipson *et al.* 2012). Within the Northeast Atlantic Ocean, ICES is in the best position to take up this role. Here, policy relevant advice is produced by committees and panels in a trans- and multi- disciplinary setting rather than by individual scientists, which has a positive effect on the value and credibility that is granted to the science delivered (Brown *et al.* 2010). Furthermore, ICES has always faced great uncertainty in advice drafting with important economic implications. Therefore, the concept of extended peer community is not new (see chapter 8, ICES 2008). The participation of geneticists and fisheries scientists within relevant ICES expert groups would increase the awareness of genetic tools available for fisheries management. This benefit was for example recognized by the WGAGFM (ICES 2012b).

Other methods to facilitate the awareness and uptake of genetics-inspired knowledge are for example by organizing workshops (Dichmont *et al.* 2012). A first type of workshop could focus on sharing knowledge within the scientific community so that other scientists, more closely involved in the management interface, are exposed to genetics: “What can genetics offer to fisheries science”. Further, stakeholder-oriented workshops are needed for communication involving a wide participant list, including fishers and industry. Communication should focus more on the best method of communicating complex methods (like genetics), which makes the inclusion of science communicators or ‘knowledge brokers’ in the planning essential (see further). A useful topic for a workshop could be “Knowledge from the latest techniques for fisheries science and management” of which genetics would be a major part. Such workshop would benefit from addressing the most important management questions, and managers’ information needs. The organization of this type of workshops, the collaboration between different expert groups and attending stakeholder meetings, could result in research projects aiming at the co-production of knowledge which meets the needs of both science and society (McNie 2007; Dankel *et al.* 2012; European Marine Board 2013).

Key to the success of such interfaces are knowledge brokers. They act as mediators between the scientific and fisheries management communities, as well as with stakeholders communities (McNie 2007; Holmes & Lock 2010). This role is granted to staff members who are actively engaged in providing advice to fisheries managers; it works best when they retain active involvement in research activities (McNie 2007; Holmes & Lock 2010; Kraak *et al.* 2013). This requires a distinctive set of skills (Holmes & Lock 2010; European Marine Board 2013); a new type of training should be provided ensuring that the policy-makers of tomorrow are science-literate and scientists are policy-literate (European Marine Board 2013). A systematic approach should be taken to developing career paths combining both worlds at the European, regional and national level (European Marine Board 2013). Additional, it is important to consider training should not only be provided to early career scientists or policy-makers, but also senior scientists and managers, mainly responsible for complicated dossier, who are usually less familiar with the latest techniques and development should be trained on a regular basis (European Marine Board 2013).

The aim of this doctoral thesis was to combine both worlds by presenting results of a very specific and technical research domain to fisheries scientists responsible for the advice drafting. The next section summarizes the results of the population genetic study (see part I) and describes how I dealt with the uncertainty associated with scientific research. The latter was achieved not only by peer-review in scientific journals, but also by discussing the results in a trans- and multidisciplinary setting at conferences and at ICES working groups and benchmark meeting.

### **3 A CASE STUDY OF THE INTERFACE BETWEEN SCIENCE AND POLICY: THE NORTHEAST ATLANTIC FLATFISH FISHERIES**

The impacts of fishing are obvious through increased mortality of target and non-target organisms. Fisheries management considers biological consequences of exploitation usually by focusing on reducing the demographic and ecological effects of fishing. However, ignoring other biological effects of fishing conflicts with the precautionary management approach to achieve sustainable exploitation of marine resources (Waples *et al.* 2008; Lowe & Allendorf 2010; Rice 2011; Laugen *et al.* 2012). In the following paragraph we focus on the flatfish fisheries with in particular turbot (*S. maximus*) and brill (*S. rhombus*). These two species are caught as by-catch in the mixed demersal fisheries in the Northeast Atlantic Ocean and until 2013, no individual analytical assessments were performed (see Chapter 1 and 4). The request from the European Commission for an analytical assessment for all commercially exploited species (see Chapter 6) presents an ideal opportunity to implement the results of “new” scientific methods, like genetics, besides the classical data sources and methods used in fisheries stock assessment. For this reason the doctoral research was embedded in a cooperation between the Flemish NFI, ILVO and an academic institution: the KU Leuven. The first partner represents the link with fisheries science and advice drafting, as they work in close contact with both the Flemish Policy Area of Agriculture and Fisheries, as well as with many ICES expert groups. Collaboration with the academic world (KU LEUVEN) included the Laboratory of Biodiversity and Evolutionary Genomics (LBEG), which benefited from many years of experience with evolutionary research on fish (e.g., sole, eel and sea bass) and the Public Management Institute (KU LEUVEN). The latter is involved in research on the different aspect of public governance with a special focus, of relevance for this project, at improving the decision-making process. Both partners are also involved in a range of national and international projects. During the course of the PhD, knowledge was gained and exchanged through communication with other scientist working on fisheries management issues, conservation and evolutionary biology.

For this purpose I heavily relied on papers in peer reviewed journals, informal meetings both within and between the different partners, as well as through the participation at conferences and training workshops.

First, knowledge is compiled on the biology, fishery and genetics of the two study species. This allowed me to assess which information is currently available, what information, provided through a genetic study, might be of interest in current approaches in fisheries science, and through which channels the results should be distributed. The biology and fishery data learned me that the highest number of turbot and brill are caught in the North Sea and for turbot the Baltic Sea also represents an important fishery. The ecosystem and the fisheries is different in these two seas, posing interesting research questions from a genetic point of view (see Chapter 3 and 4).

Like many marine species, flatfish are characterized by large population sizes; even after depletion a stock may count millions of fish (Hauser & Carvalho 2008; Branch *et al.* 2012; Pinsky & Palumbi 2013). Complete extinctions are subsequently rare (Dulvy *et al.* 2005). Therefore, historical data may provide an opportunity to better understand exploitation patterns of fisheries or stock dynamics and can help to disentangle the influence of environmental variability (e.g., climate change) and fishing pressure on fish stocks (Cardinale *et al.* 2011; Kerby *et al.* 2013; Lescrauwaet 2013). Additionally, they help to put a baseline on the status of fish stocks (Pauly 1995). A historical data analysis on turbot and plaice in the Kattegat-Skagerrak area learned us that biomass declined about 86% and 40% respectively, since 1925 (Cardinale *et al.* 2009; 2010). Maximum individual body size decreased by about 20 cm for turbot and 10 cm for plaice compared to the beginning of the time-series (Cardinale *et al.* 2009; 2010). In contrast, stable abundances have been observed in the North Sea surveys in recent years (ICES 2012b; Kerby *et al.* 2013). However, the distribution pattern in the latter basin of turbot is now different in comparison to the beginning of the 20th century (Kerby *et al.* 2013). Whereas a turbot hotspot was found off the east coast of Scotland between the 1920s and 1960s, turbot has now nearly disappeared from this region (Kerby *et al.* 2013). Currently, the main distribution of turbot lies in the southern and central parts of the North Sea, which is very similar to brill (Kerby *et al.* 2013). This change may result from intense fishing pressure, as the former spawning ground on the Aberdeen and Turbot Bank (Rae & Devlin 1972) did not appear sufficient to maintain the quantity of adult fish. Additionally, these spawning grounds were depending on immigrants from the southern region (Kerby *et al.* 2013). Due to the intensified fishing practices fewer turbot survived the northward movement, possibly causing further depletion of the northern spawning stock (Jones 1970; Rae & Devlin 1972).

Brill, in contrast, revealed a stable distribution in the southern and central North Sea with a slow expansion in the latter (Kerby *et al.* 2013). Changes in specific life history traits have been reported in the North Sea, e.g. serious reductions in age at first maturity have been revealed for flatfish (sole: Mollet *et al.* 2007; plaice: van Walraven *et al.* 2010), including turbot and brill (Jones 1974; van der Hammen *et al.* 2013). Overall, fishery poses several larger threats to populations (Ouborg *et al.* 2010). Reduced population sizes might affect the population demography by possibly altering the structure and number of migrants between populations. Inbreeding depression may affect differently life-history traits in each subpopulation as it is environment-dependent and genotype- and population-specific (Kristensen *et al.* 2010; Ouborg *et al.* 2010). This reduced genetic biodiversity in combination with the highly selective nature of fishing affects the reproductive performance, adaptation to environmental change and resistance to disease of the populations (e.g. Lage & Kornfield 2006; Volckaert 2012).

Besides the question whether turbot and brill consist of spatially and temporally discrete stocks, these observations initiate other interesting research questions relevant for fisheries management and the underlying stock assessments:

- Identifying discrete stocks involves the characterization of genetic diversity overall and within each potential stock, and test whether this genetic diversity is spatially randomly distributed (genetic theme 1 and 2, Chapter 3 and 4). At the same time, the levels of genetic diversity provide a measure of the rate at which a species may adapt in response to environmental change, and hence provide a measure of evolutionary resilience.
- The collected samples and markers could be subsequently used to assess the absolute abundance of these species by estimating the effective population size (genetic theme 7). Using genetics to estimate abundance represents a fisheries independent method and could have important validating implications for population trends from stock assessment methods (genetic theme 7, Dichmont *et al.* 2012). Although such estimates were carried out during the course of the PhD, the results were unreliable due to limited statistical power of the applied methods as only contemporary samples were available (Waples 2006; Cuveliers *et al.* 2011).
- The large distribution range of both turbot and brill is reflected in their appearances outside the Northeast Atlantic Ocean, including the Black Sea. Especially for turbot this is of significance for the next set of management questions as there was so far no genetic proof whether these individuals



represents a sister species or belong to the same genus (see Chapter 1). This question is relevant for fisheries management in regards to genetic themes 1, 2 and 3. Additional, if turbot in the Black Sea represents a different species these samples should not be included in a population genetic analysis.

- Finally, the differences in life-history traits observed over the last century both within the Baltic and North Sea, as well as between these basins raises the question whether this is a result of the different fishing methods applied in each basins or whether this divergence is environmentally driven, or a result of a combined effect. Although we were unable to assess if fishing has introduced undesirable evolutionary changes due to the limited availability of genetic markers at the start of this project, the use of genetic markers potentially under influence of natural selection proved useful for the delineation of stocks (genetic theme 4 addressed in Chapter 3).

Chapters 2 and 4 illustrated that turbot and brill show no signs of reduced neutral genetic variation over the full natural range. Turbot does however possesses lower genetic variation in comparison to other exploited flatfish species, which is most likely attributed to their short reproductive season in comparison to their conspecifics (Chapter 3, van der Hammen *et al.* 2013). Following expectations from the high genetic diversity of flatfishes and marine species in general, weak patterns of neutral population structure are evident (Chapter 3, Nielsen *et al.* 2009b; Was *et al.* 2010). Nonetheless, genetic differentiation of the Baltic population has been found and is well documented in literature (see review Johannesson & André 2006; Hemmer-Hansen *et al.* 2007a; Cuveliers *et al.* 2012; Vandamme *et al.* 2013). For some flatfish, like sole and brill, the strong salinity cline at the entrance of the Baltic Sea even represents their distributional limit (Gibson 2005; van der Hammen *et al.* 2013). Within the Northeast Atlantic Ocean, discrepancies are observed between species in their level of genetic differentiation as illustrated in Chapter 4. Whereas species like brill and plaice display an almost panmictic population structure (Was *et al.* 2010), turbot and sole reveal subtle differences between the Irish Sea and other Atlantic regions (Cuveliers *et al.* 2012). Moreover, Cuveliers *et al.* (2012) and Hemmer-Hansen *et al.* (2007b) detected reduced gene flow in sole and flounder between the North Sea and Irish Sea on one hand and the Bay of Biscay on the other hand. Furthermore, in Chapter 3 and 4 I illustrated that the use of adaptive genetic markers adds another level of fine-scale genetic differentiation. The Friesian Front in the North Sea seems to restrict gene flow between the southern and the central-northern North Sea. However, the mechanism of generating genetic differentiation has a different effect in each species (see Chapter 4, Blanchet *et al.* 2010), subsequently leading to discrepancies.

I illustrated that reproductive traits like spawning time and location in association with hydrodynamic features are the most important traits to explain the observed genetic discontinuities. This synergy was also described using bio-hydrodynamic modeling (Hufnagl *et al.* 2012; Lacroix *et al.* 2012).

Using these results for fisheries management purposes immediately raises concerns on the appropriate delineation of fish stocks. ICES advice is conducted for the entire North Sea (subarea IV) on all flatfish species mentioned above, except for brill where the North Sea also includes the eastern English Channel and Skagerrak-Kattegat ([www.ices.dk](http://www.ices.dk)). Whereas the results from Chapter 3 and 4 suggest that biologically relevant management units require a split of the North Sea stock assessment area (Waples *et al.* 2008; Reiss *et al.* 2009; Dann *et al.* 2013). These results were brought to the attention at the latest benchmark meeting for turbot (ICES 2012b), as ignoring the congruence of spatial scales between population structure of fish species and management units may result in reduced productivity and the local reduction of populations (Kenchington *et al.* 2003; Worm *et al.* 2006; Reiss *et al.* 2009). The benchmark meeting represented the ideal opportunity to discuss these findings within a management perspective. Different experts involved at such periodically organized ICES meetings provided an extensive review of the results. Ultimately, reaching a consensus between all scientists not to divide the North Sea into two stock assessment areas (ICES 2012b). The reason for this decision is as follows. Inherently the results of the genetic analysis are characterized by uncertainty. As the split in the North Sea is controversial, confirmation from other research areas would increase the reliability of the results (as thoroughly discussed in Chapter 4). For example, it remains undocumented whether these subpopulations are characterized by different life history traits and if both areas are reproductively independent (Waples & Gaggiotti 2006). Additionally, a key consideration for the delineation of genetically determined management stocks is the level of divergence that is required to justify a separate management (Waples & Gaggiotti 2006; Hauser & Carvalho 2008; Lowe & Allendorf 2010). The results obtained in Chapters 3 and 4, indicate that there might be sufficient gene flow between the two North Sea areas. From a fisheries scientist view point, splitting the North Sea in two management areas would be practically impossible, due to the limited availability of data (e.g. landings, individual length and age data) for each region to conduct statistical assessment methods (ICES 2012b). Moreover, species like turbot and brill are only caught as by-catch, implying that the effort reductions in management plans for target species in which these species are by-caught should be taken into account.

The reduction in fishing effort foreseen in the long-term management plan for sole and plaice has led to a reduced fishing mortality for turbot and brill. Therefore, from a fisheries management perspective there is no need to perform more precautionary methods by e.g. splitting the North Sea in two management units as stock assessment analysis indicated that both turbot and brill stocks are in a good healthy conditions, with increased landings and reduced fishing mortality ([www.ices.dk](http://www.ices.dk)).

Nevertheless, above mentioned results and other research illustrated that caution is warranted. The following considerations largely focus on turbot, as this species has in contrast to brill and sole a wider distribution in the Northeast Atlantic Ocean and its level of differentiation is most obvious (see Chapter 4). Nevertheless, the criteria used are just as relevant for other commercially exploited species. In accordance with other heavily exploited marine fish, high levels of neutral genetic diversity were observed (Chevolot *et al.* 2008; Larsson *et al.* 2009; Therkildsen *et al.* 2010; Cuveliers *et al.* 2011). Future research however, using adaptive markers should shed more insight whether high levels of neutral genetic variation are a prerequisite for high adaptive variation (Jakobsdóttir *et al.* 2011), the latter holding important implications for population viability and resilience. The lower levels of neutral genetic diversity observed for turbot in comparison to many other marine fish are especially a cause for concern. Hence monitoring is advised (Hauser & Carvalho 2008; Nielsen *et al.* 2009b; Laugen *et al.* 2012).

Additionally, the use of such gene-linked or adaptive genetic markers is also important to study the effect of fishing on life-history traits (attributed as fisheries-induced evolution, FIE). Although the data mentioned above on the shift in age at maturity and the reduced body size is only phenotypically observed, such changes have been observed in other exploited marine species (Jørgensen *et al.* 2007; Allendorf *et al.* 2008; Laugen *et al.* 2012). If the reduction in body size and biomass are indeed fisheries induced, turbot may already have adapted. This is for example suggested by the higher reproductive investment observed in turbot from the Baltic in contrast to the North Sea (Nissling *et al.* 2013), leaving less energy for growth (Gibson 2005; van der Hammen *et al.* 2013). In regards to the relevance for fisheries managers, including the effect of FIE is of concern for the determination of reference points (Laugen *et al.* 2012; Heino *et al.* 2013) and subsequently plays a pivotal role in harvest-control rules, especially in setting total allowable catches (Laugen *et al.* 2012; Heino *et al.* 2013). Hence, the effects of FIE holds important implications for the profitability and viability of the fishing industry (Laugen *et al.* 2012).

As for now, the reduced body size and age at maturation may have its implication in the voluntarily enforced Minimum Landing Size (MLS) of 25 or 30 cm adopted by some Member States. Depending on the chosen reference point for age at maturity, a fish of 25 or 30 cm will or will not yet have reached full sexual maturity, and as such might not yet have had the chance to reproduce and contribute to the future generations (ICES 2012b; van der Hammen *et al.* 2013).

Genetic monitoring of populations provides a valuable information tool for “seeing the fish”, tracing adaptive genetic responses and hence assist in fisheries management (Volckaert 2012) (Roy *et al.* 2012; Dann *et al.* 2013). The increasing power of high-throughput sequencing methods (Hudson 2008; Nielsen *et al.* 2012) and genotyping through sequencing approaches (Elshire *et al.* 2011; Narum *et al.* 2013) are promising steps to offer affordable high-level genotyping facilities and know-how (Dichmont *et al.* 2012; ICES 2012e; Laugen *et al.* 2012). Coupling genomic approaches with time series of historical samples will be particularly valuable to estimate the rate of evolutionary response of fish (Kuparinen & Merilä 2007; Audzijonyte *et al.* 2013), provided that they are supported by well-designed sampling protocols (see Chapter 4, Schwartz & McKelvey 2009; Dann *et al.* 2013), and advanced data analysis (including geospatial statistics and seascape genetics) (see Chapter 4, Manel *et al.* 2010; Hansen *et al.* 2012). At the same time, the advantages of genetic monitoring to protect the exploited species is gradually acknowledged (Dichmont *et al.* 2012; ICES 2012e, b). The hesitation that decision-makers and fisheries scientists may currently have about the implementation of genetics might shrink as awareness grows of the capabilities of genetics in addressing fisheries management issues. Gradually steps are taken to collect and analyze genetic data in a standardized way. This needs however, effective two-way communications through various mechanisms such as project involvement, formal committees, workshops and conferences. Moreover, research on the coupling of biological stock models to socioeconomic models describing the utility values of marine resources might help to evaluate the various impacts of fishing on ecosystem services (Fulton *et al.* 2011; Laugen *et al.* 2012). Hence, it may guide decision-makers to make trade-offs between the different management choices by making the societal and economic values more explicit. In doing so, ecosystem services valuation makes it possible to define the reasons why a management option is most beneficial for all parts of the ecosystem.

**Supplementary information**



# Supplementary information

## CHAPTER 2 DEMOGRAPHIC HISTORY OF TURBOT AND BRILL

**Table S1 List of published sequences used. \*Sequences were obtained by the FishTrace consortium**

Family	Species	GenBank accession number	Reference	
<i>Cytochrome b</i>				
Scophthalmidae	<i>Lepidorhombus boscii</i>	EU036443	(Krey,G. et al.)*	
		EF439534	(Gonzalez-Sevilla,R. et al.)*	
		EU224008	(Verrez-Bagnis,V.S. et al.)*	
		FN688338	(Kochzius et al. 2010)	
		EU513827	(Espiñeira et al. 2008)	
	<i>Lepidorhombus whiffiagonis</i>	EU036445	(Krey,G. et al.)*	
		EF427571	(Gonzalez-Sevilla,R. et al.)*	
		EU224009	(Verrez-Bagnis,V.S. et al.)*	
		EU513831	(Espiñeira et al. 2008)	
	<i>Zeugopterus punctatus</i>	EU513844	(Espiñeira et al. 2008)	
	<i>Phrynorhombus norvegicus</i>	EU492070	(van Pelt-Heerschap,H. and Stein,A.S)*	
		EU492069	(van Pelt-Heerschap,H. and Stein,A.S)*	
		EU513833.	(Espiñeira et al. 2008)	
	Soleidae	<i>Solea solea</i>	EU492072	van Pelt-Heerschap,H. and Stein,A.S
			FJ528438	Teixeira,T.F.,
JN571708			(Cuveliers et al. 2012)	



Family	Species	GenBank accession number	Reference
<i>Cytochrome oxidase subunit I</i>			
Scophthalmidae	<i>Lepidorhombus boscii</i>	JQ775048	(Costa et al. 2012)
		JQ774842	(Costa et al. 2012)
		EU513699	(Espiñeira et al. 2008)
		EU513697	(Espiñeira et al. 2008)
	<i>Lepidorhombus whiffiagonis</i>	EU513701	(Espiñeira et al. 2008)
		GU969305	(Campo and Garcia-Vazquez 2010)
	<i>Phrynorhombus norvegicus</i>	EU513705	(Espiñeira et al. 2008)
		EU513703	(Espiñeira et al. 2008)
		EU513704	(Espiñeira et al. 2008)
	<i>Zeugopterus punctatus</i>	EU513713	(Espiñeira et al. 2008)
<i>Scophthalmus aquosus</i>	EU752184	(Yancy et al. 2008)	
Soleidae	<i>Solea solea</i>	JQ774922	(Costa et al. 2012)
		EU513749	(Espiñeira et al. 2008)

**Table S2 Estimation of pairwise genetic differentiation (FST) for cyt b. Values for brill are displayed above the diagonal and for turbot below the diagonal. Significant p-values (<0.05) are in bold, significant Bonferroni correction are indicated by an asterisk.**

Region	Baltic Sea			Transition are			North Atlantic ocean		North Sea & English Channel			
Population	ALD	EST	GOT	ARK	BEL	KAT	NNS	ICE	ENS	CNS	SNS	ECH
ALD	0											
EST	0.023	0										
GOT	-0.010	-0.025	0									
ARK	0.038	-0.051	-0.006	0	-0.014	-0.061				-0.054	-0.053	-0.032
BEL	-0.037	-0.040	-0.038	-0.025	0	0.030				0.009	0.045	0.058
KAT	-0.019	-0.064	-0.024	-0.066	-0.079	0				-0.024	-0.050	-0.032
NNS	<b>0.112</b>	<b>0.183</b>	<b>0.145</b>	<b>0.202</b>	<b>0.102</b>	<b>0.141</b>	0					
ICE	<b>0.208*</b>	<b>0.333*</b>	<b>0.293*</b>	<b>0.362</b>	<b>0.215</b>	<b>0.269</b>	0.049	0				
ENS	0.053	<b>0.100</b>	<b>0.094</b>	0.110	0.008	0.048	0.061	0.076	0			
CNS	<b>0.111</b>	<b>0.184</b>	<b>0.165</b>	<b>0.199</b>	0.080	<b>0.132</b>	0.043	0.012	-0.022	0	-0.017	-0.008
SNS	0.019	0.026	0.035	0.022	-0.032	-0.029	0.060	<b>0.140</b>	-0.038	0.027	0	-0.036
ECH	0.030	<b>0.140</b>	<b>0.081</b>	<b>0.162</b>	0.026	0.085	-0.022	0.056	0.015	0.017	0.017	0
BCH	0.004	-0.006	-0.021	0.003	-0.024	-0.024	0.079	<b>0.264*</b>	0.083	<b>0.143</b>	0.016	0.045
SEI	0.036	<b>0.092</b>	<b>0.073</b>	0.107	0.005	0.046	0.029	0.077	-0.030	-0.018	-0.016	-0.011
IRS	0.030	<b>0.079</b>	<b>0.059</b>	0.090	0.001	0.036	0.022	<b>0.085</b>	-0.036	0.002	-0.031	-0.014
WIR	<b>0.122</b>	<b>0.179</b>	<b>0.155</b>	<b>0.192</b>	0.086	<b>0.131</b>	-0.007	0.045	0.002	-0.006	0.016	-0.013
WSC												
BOB	0.029	<b>0.110</b>	<b>0.079</b>	<b>0.131</b>	0.025	0.064	0.019	<b>0.071</b>	0.005	0.018	0.019	-0.022
NWS	<b>0.185</b>	<b>0.275</b>	<b>0.246*</b>	<b>0.296</b>	<b>0.163</b>	<b>0.215</b>	0.036	-0.006	0.019	-0.015	0.067	0.025
POR	<b>0.129</b>	<b>0.255</b>	<b>0.194</b>	<b>0.289</b>	<b>0.147</b>	<b>0.201</b>	-0.020	0.064	<b>0.098</b>	0.071	<b>0.118</b>	-0.027
ADR	<b>0.393*</b>	<b>0.496*</b>	<b>0.460*</b>	<b>0.548*</b>	<b>0.398</b>	<b>0.467</b>	<b>0.267*</b>	<b>0.133</b>	<b>0.178</b>	<b>0.112</b>	<b>0.283</b>	<b>0.265</b>
BLS	<b>0.271*</b>	<b>0.370*</b>	<b>0.340*</b>	<b>0.399*</b>	<b>0.266</b>	<b>0.328</b>	<b>0.193*</b>	<b>0.112</b>	<b>0.125</b>	<b>0.088</b>	<b>0.208</b>	<b>0.165</b>

<u>British Isles</u>					<u>Bay of Biscay &amp; Portugal</u>			<u>Mediterranean Sea</u>	<u>Black Sea</u>
BCH	SEI	IRS	WIR	WSC	BOB	NWS	POR	ADR	BLS
0.008	-0.060	-0.049	-0.057	-0.043	-0.036	-0.047	0.034	<b>0.193</b>	0.239
<b>0.157</b>	-0.017	0.008	0.005	0.057	-0.001	0.028	<b>0.226</b>	<b>0.323*</b>	<b>0.426</b>
0.007	-0.037	-0.037	-0.035	-0.050	-0.024	-0.034	0.027	<b>0.171*</b>	<b>0.201</b>
0.036	-0.025	-0.018	-0.031	-0.008	-0.008	-0.018	0.047	<b>0.199*</b>	<b>0.239</b>
-0.010	-0.009	-0.016	-0.028	-0.044	0.012	-0.026	0.003	<b>0.146</b>	<b>0.167</b>
0.002	0.007	-0.003	-0.022	-0.013	0.027	-0.022	-0.003	<b>0.119</b>	0.142
0	0.068	0.056	0.035	-0.009	<b>0.090</b>	0.028	-0.032	0.056	0.062
0.048	0	-0.035	-0.028	-0.010	-0.039	-0.019	0.106	<b>0.243*</b>	<b>0.305</b>
0.032	-0.027	0	-0.025	-0.010	-0.028	-0.015	0.085	<b>0.223*</b>	<b>0.266</b>
0.105	-0.011	-0.005	0	-0.009	-0.012	-0.026	0.058	<b>0.199*</b>	<b>0.242</b>
				0	0.004	-0.016	0.002	<b>0.139*</b>	<b>0.157</b>
0.046	-0.013	-0.011	0.020		0	-0.005	0.117	<b>0.259*</b>	<b>0.318</b>
<b>0.211</b>	0.032	0.035	-0.029		0.053	0	0.020	<b>0.169*</b>	<b>0.201</b>
0.121	0.050	0.047	0.025		0.005	0.059	0	0.024	0.030
<b>0.482*</b>	<b>0.198</b>	<b>0.225</b>	<b>0.161</b>		<b>0.247*</b>	0.075	<b>0.324</b>	0	0.028
<b>0.336*</b>	<b>0.140</b>	<b>0.151</b>	<b>0.139</b>		<b>0.150</b>	<b>0.098</b>	<b>0.200</b>	<b>0.162</b>	0

Figure S1 Mismatch distribution of cytb mtDNA haplotypes in A) Turbot in Northeast Atlantic and B) Brill, C) and D) are respectively turbot and brill in Mediterranean Sea. Pairwise observed and expected nucleotide differences among European haplotypes of the cytb mtDNA based on a model of sudden population expansion

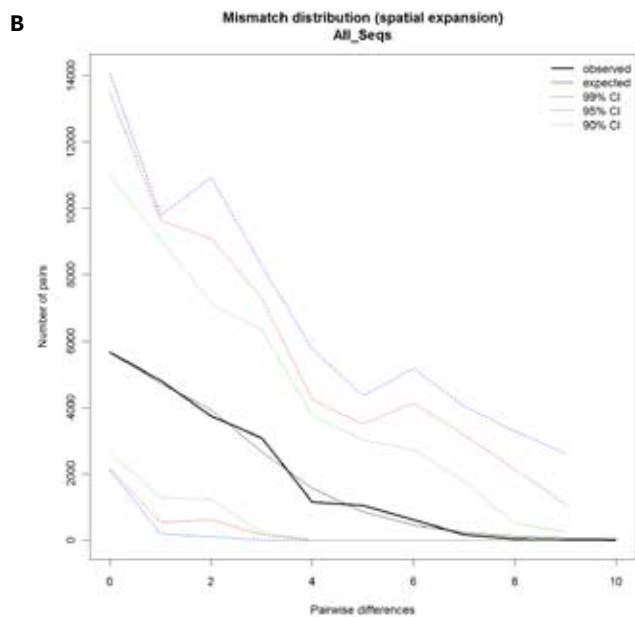
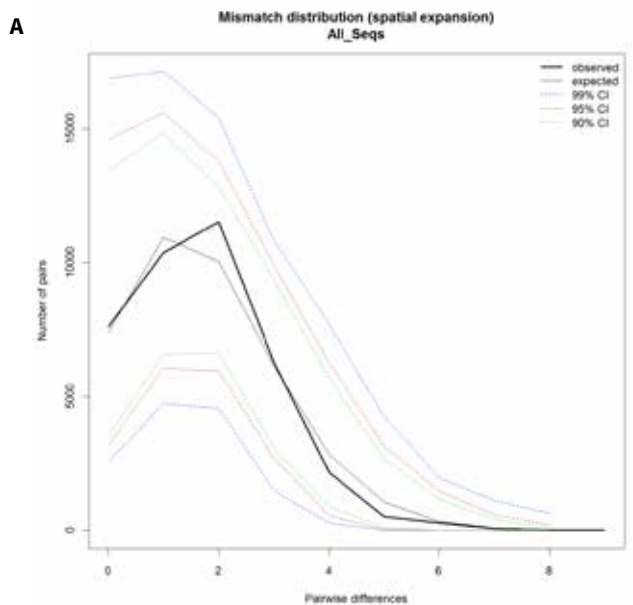

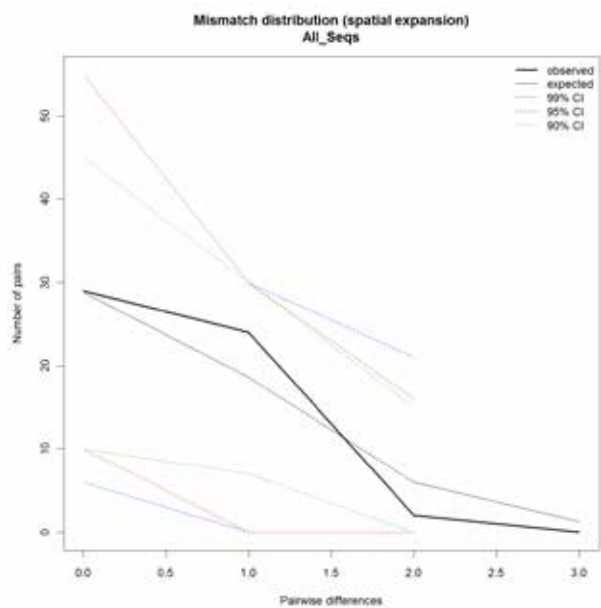
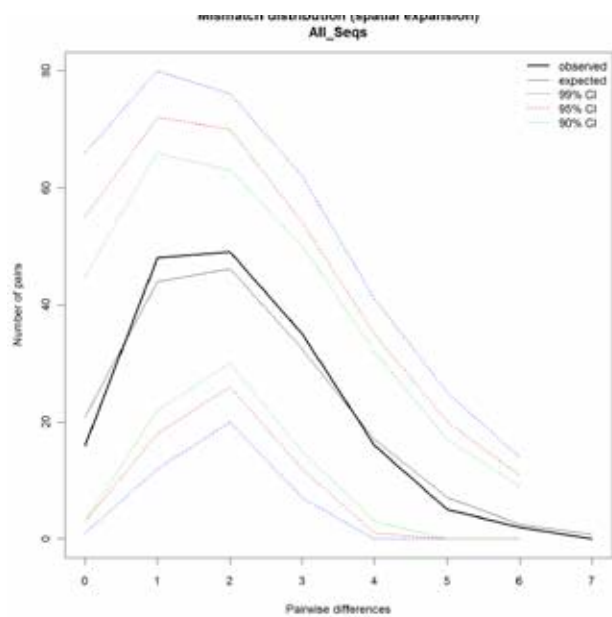
**C****D**

**Figure S2 Bayesian skyline plots (BSPs) showing changes in population size through time in the northeast Atlantic Ocean for: (A) turbot, (B) brill. These historical demographic trends of the *cyt b* lineage are represented by the 0.5% and 2.5% molecular clocks. The relative population size is measured as a product of effective population size and generation. X-axis: time (in years), the upper axis is the time measured with the 2.5% molecular clock and the lower axis shows time with the 0.5% molecular clock (measured as a product of effective population size and generation). The black line represents the median estimate; upper and lower limits (95% highest posterior density) are drawn in grey.**

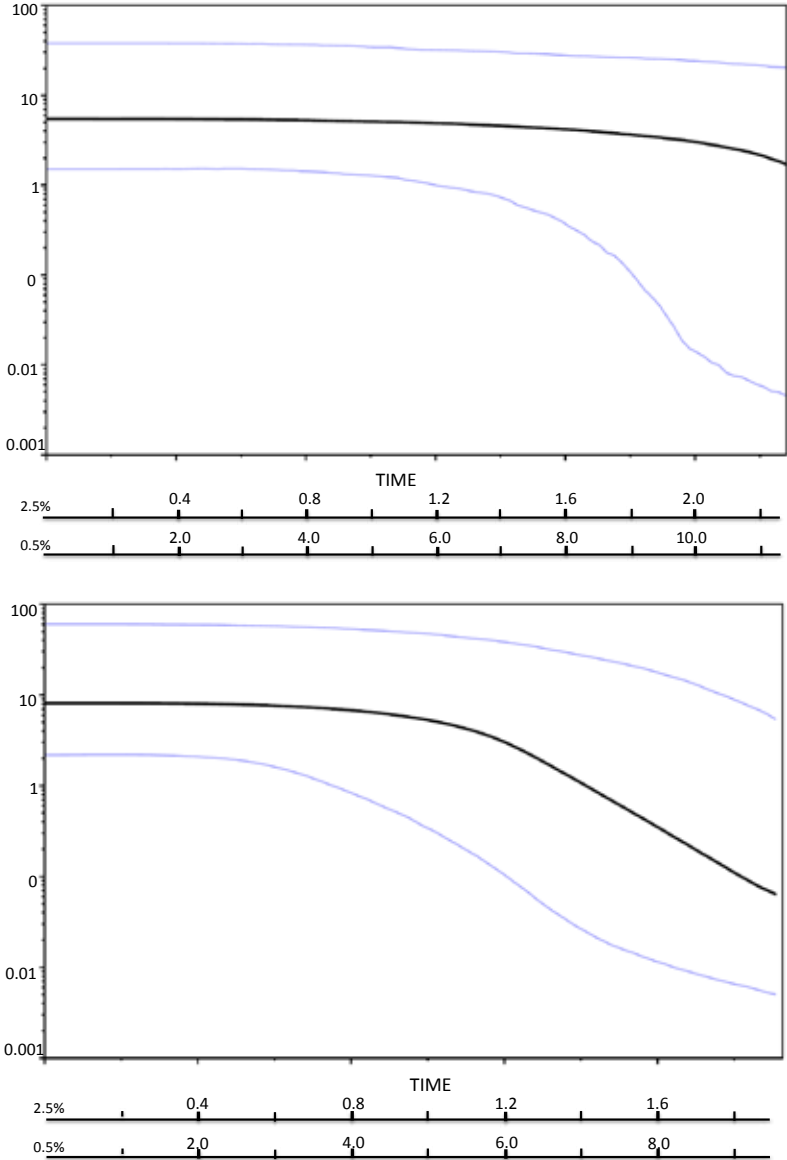

Bayesian skyline plot analysis was used to date major historic shifts in population size within populations. Analyses were performed for brill including all Northeast Atlantic samples because of the low number of haplotypes observed within some populations. For turbot we excluded samples from the Baltic Sea as this area harbours a well-known distinct population (Nielsen *et al.* 2004; Vandamme *et al.* 2013). The plot shows that significant expansion took place between 1.2 and 6.0 Mya for brill, whereas the population size of turbot showed only a minor trend of expansion taking place before the period between 2.0 and 10.0 Mya.

**Figure S3 Scenarios simulated in the DIYABC analysis for cytb. The yellow branch represents a putatively unsampled population of effective size N4**

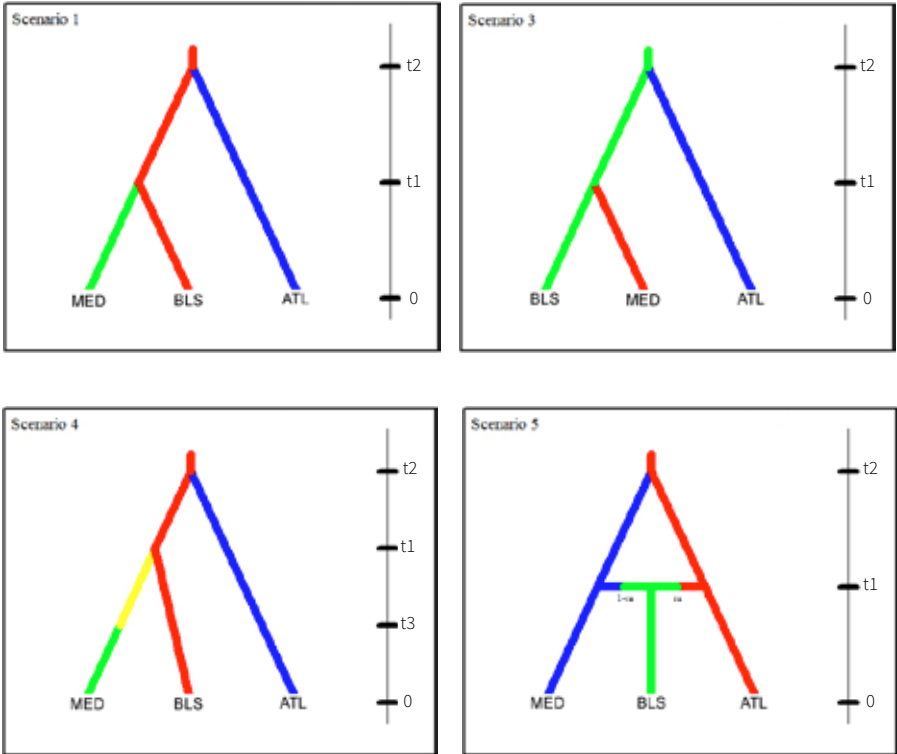

## CHAPTER 3 SEASCAPE GENETICS OF TURBOT

### Materials and methods

#### *Samples*

As mentioned in the core text, turbot samples were collected at 290 unique locations across the Northeast Atlantic Ocean during the period 2006-2010 (Table 1, Figure 1). These samples however, have to be grouped for classical population genetic analysis. Therefore, ICES fisheries subdivisions were taken as a starting point. Overall, samples covered in the Baltic Sea the rectangles 32, 28, and 24. Kattegat and Skagerrak were covered by rectangles IIIc, IIIb and IIIa. In the Northeast Atlantic Ocean samples covered the North Sea and English Channel (IVb, IVc, VIId, VIIE), the Celtic and Irish Sea (VIIf, VIIg, VIIa), the west coast of Ireland (VIa and VIIb) and the Bay of Biscay (VIIIa,b) (Table 1, Figure 1). At three locations, samples from different ICES subdivision were pooled. This is the case for the samples taken at the west Coast of Ireland and Scotland and the samples off the Estonian Coast. The former samples were pooled into one group as the majority of the samples were collected at the west Coast of Ireland (N = 17). As the sample size for the west coast of Scotland (N = 9) was too small to analyze as an independent group, they were pooled. Half of the Estonian samples were taken in area 28 at one station, the others in 32. However, all samples were taken close to the coast and in a zone where salinity drops (more brackish water). For this reason pooling these samples is justified. For the ICES subdivision of the central North Sea, we split the area into two groups (central North Sea and German Bight), following the indications that different spawning grounds may be present at either side of the North Sea (Rae & Devlin 1972; Kerby *et al.* 2013; van der Hammen *et al.* 2013), hence encompassing different genetic variation.

In order to cover the full distributional and environmental (temperature and salinity) range of turbot, additional samples were included from previous studies or sample archives. However, these samples were georeferenced as a pooled sampling location instead of a unique location for each individual sample. On a latitudinal scale, samples were collected in the south from Portugal (IXa and VIIIc) (Vilas *et al.* 2010), and in the north from the Southwest coast of Norway (IVa) (Coughlan *et al.* 1998) and Iceland (Va2), reflecting a wide range of temperatures. Large salinity differences were observed with samples collected at two additional locations in the Baltic Sea: Gotland Island (28) and Åland archipelago (29) (Florin & Hoglund 2007) (Table 1, Figure 1). Overall, this sampling scheme covered both the latitudinal and longitudinal margins of the distribution of turbot.



## ***Geographic structure of neutral and adaptive genetic variation***

The contemporary population structure of turbot results from both historical and contemporaneous evolutionary forces. To investigate the influence of these evolutionary forces on the demographic structure, genetic markers were subdivided in two panels (neutral and full marker panel) based on an outlier analysis. Using only the neutral markers, the amount of genetic variation within samples expressed as allelic richness (following El Mousadik & Petit 1996), number of alleles and observed and expected heterozygosity were estimated using the FSTAT v.2.9.3 program (Goudet 1995). Genetic differentiation was assessed for both marker sets by pairwise *F<sub>ST</sub>* between all samples (using Weir & Cockerham 1984 statistics) using FSTAT. Additionally, Bayesian analysis were conducted with STRUCTURE v.2.3.3. (Pritchard *et al.* 2000). To enable the discovery of fine scale population subdivision besides the strong phylogeographic effect of the Baltic Sea, the delta K plots are illustrated for K= 2-10.

In Figure S2 the cluster memberships obtained from the STRUCTURE output is represented for the full marker panel. Just like Figure 2, the visualisation of these maps can be accessed at the web-based geo-visualisation available at [https://fishreg.jrc.ec.europa.eu/map/genetics\\_geobrowser](https://fishreg.jrc.ec.europa.eu/map/genetics_geobrowser) which allows for the interactive visualisation of alleles and genotype frequencies of several marine species. The colours used to represent the frequencies in the population maps are derived from the CMYK colour model. Each colour is assigned to each cluster represented. The colours are mixed according to the proportions of the representative clusters at each geographic location; for details see Mac Aoidh *et al.* (2013).

## **Spatial, environmental and temporal correlation analyses**

### ***Environmental variables***

Seascape genetic analyses were performed with a matrix of nine environmental variables. These variables were extracted from the ECOSMO model (Schrum *et al.* 2003). Habitat variables like temperature and salinity are most commonly used in seascape genetic analyses of marine species as their effect on the physiology of the organisms has been well documented in the literature. Many recent publications demonstrate their impact on adaptive genetic variation (e.g. Poulsen *et al.* 2011; Limborg *et al.* 2012; Teacher *et al.* 2013). Additional habitat variables were included because of their effect on specific life stages of turbot. Within the Baltic Sea exchange between surface and bottom water is restricted and renewal of bottom water is mainly driven by saline water inflow from the North Sea.

However, such inflow events are highly irregular, resulting in decreased salinity and oxygen conditions close to the bottom. Thus to avoid the low oxygen conditions marine fishes have developed the ability to produce pelagic eggs (Nissling *et al.* 2002). Primary production represents the main carbon source for the early life stages and may differ considerably between regions, depending on freshwater run-off and oceanographic conditions mixing the water column. Furthermore, three hydrodynamic variables were included in the analysis: depth of the pycnocline, bottom shear stress and stratification index. Water masses are vertically layered by density. Tidal currents are strong features in the North Sea, stirring the entire water column in the southern North Sea and Channel. In other areas, the water layers become homogenized due to turbulence up to a certain depth. The depth at which the vertical density gradient is the highest, is the depth of the pycnocline. The stratification index represents the maximum of this gradient. These features are strongly influenced by seasonality and affect the environment in several ways. The distribution and circulation of the water masses are of utmost importance for the biological productivity, distribution and abundance of species and for transport and concentration of non-living matter, including suspended matter, organic matter and nutrients (OSPAR Commission 2000). Bottom shear stress, the shearing force due to the current at the bottom, relates to the amount of diatoms and primary production that can be found at the bottom of the sea. For example, due to the turbulent conditions in the southern North Sea some 1% of the annual primary production is buried in the sediment. On the other hand, the stable haline stratification (caused by salinity differences) of the Baltic Sea results in negligible sediment fluxes. At the German Bight a maximum integrated biomass is found due to the vertical transport driven by near bottom inflow of saltier North Sea water and a considerable river runoff. Indirectly, sediment type also represents the amount of bottom shear stress. Although this factor is rarely included in seascape genetic analyses looking for an association between environmental parameters that have an effect on the genetic structure, its effect was convincingly illustrated by Delavenne (2012).

## RESULTS

### Genetic diversity of neutral markers

The mean number of alleles per locus varied from 5.3 in the Arkona Basin (ARK10) to 8.5 in the Southeast Ireland (SEI09) sample. Other samples with a low number of alleles, e.g. the Central and Southern North Sea (CNS10, SNS07 respectively), Bristol Channel (BCH07) and the Bay of Biscay (BOB09), corresponded with the lowest sample sizes ( $N = 14$ ,  $N = 18$ ,  $N = 16$ , and  $N = 18$  respectively). The estimation of allelic richness (based on eight diploid individuals) confirmed a down-bias due to low sample size (Table 1). Allelic richness ranged from 4.0 in the Arkona Basin (ARK10) to 5.0 in the Belt Sea (BEL09). Average observed heterozygosity varied from 0.563 in the southern North Sea (SNS07) to 0.684 in the central North Sea (CNS10). Expected heterozygosity ranged from 0.598 in the sample of the Arkona Basin to 0.680 in the Bay of Biscay (BOB09) (Table 1).

### Outlier analyses

Based on environmental differences between regions, pairwise comparisons between population samples were conducted to test for possible signals of selection. The LOSITAN analysis indicated that loci *SmaUSC-E4* and *SmaUSC-E7* exceeded the 95% confidence limit on neutral expectations in the pairwise comparisons involving the Baltic Sea, irrespective of the mutation model (Table S2). Locus *SmaI-152INRA* on the other hand, exceeded the 95% confidence limit in comparisons involving the North Sea and the Iberian samples, whereas analysis including the North Sea and Irish shelf populations exceeded the 99% confidence interval (Table S2). Except *SmaUSC-E7*; none of the other loci was identified as a potential outlier using the Bayesian analysis. All comparisons involving the Baltic Sea identified *SmaUSC-E7* as outlier according to prior odds favoring the neutral model of 10 and a  $q < 10\%$  (Table S2). These three loci were excluded from the neutral dataset in any further analysis, as all three loci were significantly identified as outlier in the global analysis and at least two pairwise comparisons. Whether these loci or their genomic regions might be influenced by selection will be further investigated in the seascape genetic analysis.

### Geographic structure of neutral and adaptive genetic variation

The spatial patterns of differentiation among turbot populations were explored while keeping individual samples separate (not pooling temporal replicates). The overall  $F_{ST}$  value was 0.008 ( $p < 0.001$ ) for the neutral dataset and 0.016 ( $p < 0.001$ ) when all loci were included. For single loci, the estimated levels of genetic differentiation ranged from 0.000 (*SmaUSC-E10*) to 0.024 (*Sma3-12INRA*) for 14 putative neutral markers.

The three outlier loci, *SmaI-152INRA*, *SmaUSC-E4* and *SmaUSC-E7* clearly showed higher overall single  $F_{ST}$  values, 0.035, 0.066 and 0.067 respectively.

Pairwise  $F_{ST}$  values based on the neutral markers indicated that 266 out of 841 (32%) pairwise tests showed  $p$ -values below 0.05. Most of these (200 of 266) were associated with Baltic Sea (ALD-EST-GOT-ARK-BEL) samples and/or Irish samples (SEI-IRS-WIR). However, only 35% of these tests were significantly different from zero after Bonferroni correction (Table S2). Using all 17 loci, 35% of the pairwise  $F_{ST}$  estimates had  $p$ -values below 0.05 (Table S2). After Bonferroni correction, 57% of these remained significant, although this was mainly driven by the Baltic samples (ALD-EST-GOT-ARK and BEL) (Table S2). Additional significant genetic differentiation was observed between the northern North Sea (NNS) sample and the southern North Sea (SNS). Furthermore, several comparisons involving Irish samples (BCH-SEI-IRS-WIR) were significant (Table S2). Besides significant geographic differentiation, we also observed significant differentiation among temporal replicates ( $p < 0.05$ ) (Table S2) ranging from 0.006 between samples of the southern North Sea (SNS07 vs SNS09) and Irish Sea (IRS09 and IRS06) to 0.010 between the temporal samples from the central North Sea (CSN10 vs. CNS07).

Bayesian clustering of the full marker panel points to the presence of four genetic clusters ( $K = 4$ , Figure S2), although individual genotypes indicated admixture between clusters. Similar to the neutral marker set, a first cluster was suggested including samples of the Baltic proper (ALD03, EST10 and GOT08), Arkona Basin and Kattegat. A second group consisted mainly of individuals from Ireland: SEI09, IRS09 and WIR09, with assignment proportions based on STRUCTURE Q-values of 0.641, 0.868, 0.954, respectively. Although neutral loci do not significantly discriminate any further between Northeast Atlantic samples, the outlier loci significantly indicate the presence of a fourth cluster within the North Sea. Individuals from the northern North Sea (NNS97, assignment 0.893) and Iceland form one group, with large contributions of samples from the central North Sea (CNS10 and ENS10; cluster membership was equal to 0.587 and 0.671, respectively). Samples from the southern North Sea however, were more affiliated with the Irish cluster. Samples from the English and Bristol Channel are made up of mixed genotypes (Figure S2). We noted a peculiar assignment of the southernmost samples (NWS and POR). Although nearly 60% of the individuals were assigned to the Irish group, 30% of these individuals were more closely related to the northern North Sea group and 10% of the cases to the Baltic cluster. Careful consideration is needed when interpreting population structure based on outlier loci. If genetic differentiation is primarily determined by natural selection, the pattern of genetic similarities among populations will vary from locus to locus (Lamichhaney *et al.* 2012).

Moreover, the inclusion of such loci may violate model assumptions of STRUCTURE (Pritchard *et al.* 2000) if outlier loci are under fluctuating environmental selection pressures uncoupled from the general population structuring process (migration and drift) (Limborg *et al.* 2012). However, these loci may elucidate evolutionary significant population units that could not be detected with neutral markers alone. We did neither observe systematic trends of linkage disequilibrium nor deviation from Hardy-Weinberg equilibrium. Hence, we argue that careful inclusion of selected loci remains useful for assessing spatial scales of demographically and reproductively isolated populations (Limborg *et al.* 2012; Nielsen *et al.* 2012; Bradbury *et al.* 2013).

**Table S1 Information on the primer conditions of three multiplex reactions of microsatellites of *Scophthalmus maximus*. Linkage groups were attributed according to Bouza et al. (2008). Information includes the multiplex set, loci, linkage group (LG), GenBank Accession number, concentration (Conc), and annealing temperature (Ta) and number of cycles.**

Multiplex	Locus	LG	GenBank Accession No.	Conc (µM)	Ta (°C)
1	<i>Sma3-12INRA</i>	6	Pr010071602.1	0.1	
1	<i>SmaUSC-E36</i>	9	FE947646	0.2	
1	<i>SmaUSC-E41</i>	9	FE948445	0.2	58 °C: 35x
1	<i>Sma3-129INRA</i>	17	Pr010071606.1	0.1	
1	<i>SmaUSC-E2</i>	9	FE946387	0.4	
1	<i>SmaUSC-E32</i>	10	FE946913	0.1	
1	<i>Sma1-152INRA</i>	5	Pr010071607.1	0.05	
1	<i>SmaUSC-E4</i>	-	FE949040	0.05	
1	<i>SmaUSC-E28</i>	14	FE946191	0.05	
2	<i>SmaUSC-E21</i>	12	FE943127	0.2	
2	<i>SmaUSC-E8</i>	-	FE946444	0.4	62 °C to 55 °C with -1 °C/
2	<i>SmaUSC-E7</i>	6	FE951426	0.05	55 °C: 19x cycle: 7x
2	<i>SmaUSC-E10</i>	13	FE945293	0.2	
2	<i>Sma1-125INRA</i>	13	Pr010071605.1	0.05	
2	<i>Sma3-8INRA</i>	16	Pr010071600.1	0.2	
3	<i>SmaUSC-E40</i>	18	FE945308	0.4	
3	<i>SmaUSC-E5</i>	9	FE950878	0.4	
3	<i>SmaUSC-E1</i>	17	FE944126	0.2	58 °C: 30x
3	<i>SmaUSC-E26</i>	-	FE951486	0.05	
3	<i>Sma5-IIIINRA</i>	22	Pr010071604.1	0.2	
3	<i>Sma4-14INRA</i>	7	Pr010071603.1	0.2	

PCRs were carried out in 10 µL volumes using a Multiplex PCR kit (Qiagen). Forward and reverse primers and 1 µL of template DNA. PCR conditions were as follow: 95 °C for 15 min. 95 °C for 30 s. Ta (see Table S1) for 90 s. 72 °C for 60 s. 60 °C for 30 min. However, PCR 2 followed a touchdown protocol with the following conditions: 95 °C for 15 min, 95 °C for 30 s. Ta (see Table S1) for 90 s. 72 °C for 60 s. 95 °C for 30 s. Ta (see Table S1) for 90 s. 72 °C for 60 s. 60 °C for 30 min. All reactions are concluded by storage at 10 °C.

**Table S2 Summary of significant results of the outlier analysis as calculated with LOSITAN and BAYESCAN. Results from the pairwise comparisons across groups of populations include samples from the Baltic Sea (BAL = Åland Sea, Gotland, Estonia), the North Sea (NS = central, eastern and southern North Sea), Irish samples (IRS = southeast Ireland, Irish Sea, West coast of Ireland) and Iberian samples (IBE = Bay of Biscay, northwest Spain and Portuguese coast). 95 and 99 indicate that the locus-specific confidence interval was above the 95% or the 99% in LOSITAN. Outliers indicated in bold remained significant following FDR control < 10%. The values 3 and 10 indicate that the locus was an outlier in BAYESCAN analysis with prior odds favoring the neutral model of 3 and 10 respectively. Outlier loci significant according to the  $q < 10\%$  are highlighted in bold.**

Locus	LOSITAN					BayeScan					
	Stepwise		Infinite alleles			Stepwise		Infinite alleles			
	P (Simul FST < sample FST)		P (Simul FST < sample FST)			P (Simul FST < sample FST)		Log <sub>10</sub> (PO)			
	SmaUSC-E4	SmaUSC-E7	SmaUSC-E4	SmaUSC-E7	SmaUSC-E4	SmaUSC-E7	SmaUSC-E4	SmaUSC-E7	SmaUSC-E4	SmaUSC-E7	
Global analysis	<b>99</b>	<b>99</b>	<b>99</b>	<b>99</b>	<b>99</b>	<b>99</b>	<b>99</b>	<b>99</b>	<b>10</b>	<b>3</b>	<b>10</b>
BAL/NS		99	99		<b>99</b>	<b>99</b>					<b>10</b>
BAL/IBE		99	95			99		99			<b>10</b>
BAL/IRS								95			<b>10</b>
NS/IRS	<b>99</b>			<b>99</b>							
NS/IBE	95			95							

**Table S3 Estimation of pairwise genetic differentiation ( $F_{ST}$ ) for all 14 neutral microsatellites (above diagonal) and all 17 microsatellites (below diagonal). Significant  $p$ -values ( $< 0.05$ ) are listed in bold and significant values after Bonferroni corrections are marked with an asterisk.**

Region	BALTIC SEA						
	Population	ALD03	EST10	GOT08	ARK10	BEL10	BEL09
ALD03	-	<b>0.004</b>	<b>0.001</b>	<b>0.024</b>	<b>0.005</b>	<b>0.020*</b>	-0.003
EST10	<b>0.148*</b>	-	<b>0.004*</b>	0.011	<b>0.000</b>	<b>0.019*</b>	-0.005
GOT08	<b>0.012</b>	<b>0.077*</b>	-	<b>0.025</b>	<b>0.004*</b>	<b>0.010</b>	<b>-0.001</b>
ARK10	<b>0.171*</b>	<b>0.110*</b>	<b>0.110*</b>	-	0.008	<b>0.040</b>	0.009
BEL10	<b>0.109*</b>	<b>0.080*</b>	<b>0.054*</b>	0.004	-	<b>0.007</b>	-0.007
BEL09	<b>0.120*</b>	<b>0.061</b>	<b>0.067*</b>	<b>0.110*</b>	<b>0.052</b>	-	<b>0.009</b>
KAT09	<b>0.033</b>	0.053	-0.006	<b>0.128</b>	<b>0.058</b>	0.025	-
NNS97	<b>0.077*</b>	<b>0.199*</b>	<b>0.077*</b>	<b>0.263*</b>	<b>0.193*</b>	<b>0.115*</b>	<b>0.065*</b>
ICE	<b>0.098*</b>	<b>0.137*</b>	<b>0.067*</b>	<b>0.195*</b>	<b>0.143*</b>	<b>0.083*</b>	<b>0.062</b>
ENS10	<b>0.074*</b>	<b>0.098*</b>	<b>0.047*</b>	<b>0.195*</b>	<b>0.132*</b>	<b>0.050</b>	<b>0.026</b>
CNS10	<b>0.063*</b>	<b>0.148*</b>	<b>0.050</b>	<b>0.256*</b>	<b>0.176*</b>	<b>0.086</b>	<b>0.033</b>
CNS07	-	-	-	-	-	-	-
SNS07	-	-	-	-	-	-	-
SNS09	<b>0.062*</b>	<b>0.128*</b>	<b>0.049*</b>	<b>0.186*</b>	<b>0.104*</b>	0.019	0.015
EEC07	<b>0.113*</b>	<b>0.102*</b>	<b>0.064*</b>	<b>0.144*</b>	<b>0.085*</b>	0.012	<b>0.045</b>
EEC09	<b>0.062*</b>	<b>0.117*</b>	<b>0.039*</b>	<b>0.182*</b>	<b>0.110*</b>	<b>0.032</b>	0.013
WEC10	<b>0.058</b>	<b>0.129*</b>	<b>0.031</b>	<b>0.181§</b>	<b>0.092*</b>	0.014	0.003
BCH07	-	-	-	-	-	-	-
BCH09	<b>0.019</b>	<b>0.174*</b>	<b>0.023</b>	<b>0.195*</b>	<b>0.109*</b>	<b>0.073</b>	0.018
BCH10	<b>0.057*</b>	<b>0.081*</b>	<b>0.025*</b>	<b>0.077*</b>	<b>0.034*</b>	<b>0.025</b>	0.018
SEI09	<b>0.038*</b>	<b>0.092*</b>	<b>0.014</b>	<b>0.113*</b>	<b>0.053*</b>	0.023	-0.001
IRS06	-	-	-	-	-	-	-
IRS07	-	-	-	-	-	-	-
IRS09	<b>0.056*</b>	<b>0.102*</b>	<b>0.023*</b>	<b>0.155*</b>	<b>0.085*</b>	<b>0.034</b>	-0.008
WIR09	<b>0.104*</b>	<b>0.081*</b>	<b>0.062*</b>	<b>0.164*</b>	<b>0.085*</b>	-0.003	<b>0.033</b>
BOB07	-	-	-	-	-	-	-
BOB09	<b>0.081*</b>	<b>0.084*</b>	<b>0.037*</b>	<b>0.110*</b>	<b>0.050*</b>	0.005	<b>0.020</b>
NWS00	<b>0.035*</b>	<b>0.124*</b>	<b>0.022</b>	<b>0.183§</b>	<b>0.110*</b>	<b>0.057</b>	0.008
POR00	<b>0.096*</b>	<b>0.084*</b>	<b>0.045*</b>	<b>0.139§</b>	<b>0.089*</b>	<b>0.048</b>	<b>0.032</b>



NORTHERN ATLANTIC					NORTHEASTERN ATLANTIC					
NNS97	ICE	ENS10	CNS10	CNS07	SNS07	SNS09	EEC07	EEC09	WEC10	BCH07
<b>0.006</b>	<b>0.013*</b>	<b>0.013*</b>	<b>0.009</b>	<b>0.011*</b>	<b>0.013*</b>	<b>0.012*</b>	<b>0.004</b>	<b>0.013*</b>	<b>0.002</b>	<b>0.000</b>
<b>0.013*</b>	<b>0.008*</b>	<b>0.006</b>	<b>0.004*</b>	<b>0.018*</b>	<b>0.018*</b>	<b>0.014*</b>	<b>0.009*</b>	<b>0.014*</b>	<b>-0.001</b>	<b>0.009*</b>
<b>0.013*</b>	0.004	<b>0.007</b>	<b>0.004</b>	<b>0.008*</b>	<b>0.003</b>	<b>0.006</b>	<b>0.003</b>	<b>0.008</b>	<b>0.005</b>	-0.003
<b>0.033</b>	<b>0.026</b>	<b>0.023</b>	<b>0.022</b>	<b>0.041*</b>	<b>0.048</b>	<b>0.028</b>	<b>0.029</b>	<b>0.022</b>	0.011	<b>0.033</b>
<b>0.011*</b>	<b>0.005</b>	<b>0.003</b>	<b>-0.003</b>	<b>0.012*</b>	<b>0.015*</b>	<b>0.003</b>	<b>0.000</b>	<b>0.005</b>	-0.007	<b>0.003</b>
<b>0.012</b>	0.001	0.002	-0.001	<b>0.010</b>	<b>0.009</b>	<b>0.006</b>	<b>0.003</b>	<b>0.013</b>	-0.001	0.008
<b>0.004</b>	<b>0.005</b>	0.000	-0.003	<b>0.006</b>	<b>0.006</b>	0.002	<b>0.001</b>	-0.004	-0.007	<b>0.001</b>
-	<b>0.009</b>	<b>0.009</b>	<b>0.012</b>	<b>0.012*</b>	<b>0.011</b>	<b>0.007*</b>	<b>0.007</b>	<b>0.014*</b>	0.002	<b>0.004</b>
<b>0.023</b>	-	0.002	-0.001	<b>0.009*</b>	0.010	<b>0.008</b>	0.002	0.002	-0.001	0.003
<b>0.021</b>	0.008	-	0.000	<b>0.007*</b>	<b>0.015</b>	<b>0.009</b>	0.002	<b>0.006</b>	-0.001	0.003
-0.012	-0.004	-0.016	-	<b>0.010</b>	0.008	<b>0.006</b>	-0.001	<b>0.008</b>	-0.008	-0.004
-	-	-	-	-	0.005	<b>0.008</b>	0.003	<b>0.010*</b>	0.004	-0.005
-	-	-	-	-	-	<b>0.006</b>	0.005	<b>0.018</b>	<b>0.016</b>	-0.006
<b>0.059*</b>	<b>0.078*</b>	<b>0.034</b>	<b>0.044</b>	-	-	-	<b>0.008</b>	0.006	0.005	0.001
<b>0.057*</b>	0.012	0.014	0.028	-	-	<b>0.038</b>	-	<b>0.007</b>	-0.005	-0.009
<b>0.024*</b>	<b>0.029</b>	0.003	0.004	-	-	0.002	0.013	-	0.002	0.005
<b>0.034</b>	<b>0.048</b>	0.019	0.019	-	-	-0.015	0.013	-0.010	-	-0.004
-	-	-	-	-	-	-	-	-	-	-
<b>0.038*</b>	<b>0.064</b>	<b>0.042</b>	<b>0.034</b>	-	-	0.006	<b>0.057</b>	0.009	-0.004	-
<b>0.085*</b>	<b>0.054*</b>	<b>0.043*</b>	<b>0.062</b>	-	-	<b>0.034</b>	<b>0.024</b>	<b>0.028*</b>	<b>0.026</b>	-
<b>0.056*</b>	<b>0.051*</b>	<b>0.029*</b>	<b>0.038</b>	-	-	0.007	0.022	<b>0.006</b>	-0.007	-
-	-	-	-	-	-	-	-	-	-	-
-	-	-	-	-	-	-	-	-	-	-
<b>0.054*</b>	<b>0.061*</b>	<b>0.029*</b>	<b>0.035</b>	-	-	0.008	<b>0.038</b>	0.005	-0.006	-
<b>0.103*</b>	<b>0.077*</b>	<b>0.035</b>	<b>0.066</b>	-	-	0.007	0.018	0.018	0.009	-
-	-	-	-	-	-	-	-	-	-	-
<b>0.087*</b>	<b>0.047*</b>	<b>0.034</b>	<b>0.052</b>	-	-	<b>0.019</b>	0.004	<b>0.020</b>	0.008	-
<b>0.027*</b>	<b>0.032</b>	<b>0.010</b>	0.005	-	-	<b>0.014</b>	<b>0.036</b>	<b>-0.001</b>	0.006	-
<b>0.063</b>	0.006	0.015	0.024	-	-	<b>0.067</b>	0.007	<b>0.028</b>	<b>0.047</b>	-

IRISH SHELF					NORTHEASTERN ATLANTIC					
SEI09	IRS06	IRS07	IRS09	WIR09	BCH09	BCH10	BOB07	BOB09	NWS00	POR00
<b>0.010*</b>	<b>0.009</b>	<b>0.005</b>	<b>0.017*</b>	<b>0.024*</b>	<b>0.010</b>	<b>0.002</b>	<b>0.014*</b>	<b>0.016*</b>	<b>0.014*</b>	<b>0.011</b>
<b>0.013*</b>	<b>0.023*</b>	<b>0.020*</b>	<b>0.021*</b>	<b>0.032*</b>	<b>0.014*</b>	0.003	<b>0.019*</b>	<b>0.019*</b>	<b>0.014*</b>	<b>0.015*</b>
<b>0.006*</b>	<b>0.018*</b>	<b>0.005</b>	<b>0.014*</b>	<b>0.023*</b>	<b>0.003</b>	0.001	<b>0.009</b>	<b>0.014</b>	<b>0.008</b>	<b>0.006</b>
<b>0.026*</b>	<b>0.042</b>	<b>0.035</b>	<b>0.039*</b>	<b>0.046*</b>	<b>0.028</b>	<b>0.026</b>	<b>0.036*</b>	<b>0.036</b>	<b>0.036*</b>	<b>0.026</b>
<b>0.002</b>	<b>0.012*</b>	<b>0.008</b>	<b>0.008*</b>	<b>0.018*</b>	<b>0.003</b>	0.002	<b>0.010*</b>	<b>0.012*</b>	<b>0.010*</b>	<b>0.008*</b>
<b>0.007</b>	<b>0.016</b>	0.009	<b>0.013*</b>	<b>0.020*</b>	0.001	<b>0.003</b>	<b>0.009</b>	<b>0.013</b>	0.004	0.009
0.001	-0.002	0.003	<b>0.004</b>	<b>0.014</b>	0.000	-0.004	<b>0.003</b>	0.010	<b>0.004</b>	<b>0.007</b>
<b>0.010*</b>	<b>0.012*</b>	<b>0.008</b>	<b>0.013*</b>	<b>0.027*</b>	<b>0.008</b>	<b>0.002</b>	<b>0.016*</b>	<b>0.022*</b>	<b>0.012</b>	<b>0.014</b>
<b>0.003</b>	<b>0.013*</b>	<b>0.012</b>	<b>0.010*</b>	<b>0.027*</b>	0.002	0.004	<b>0.008</b>	<b>0.010</b>	0.001	0.005
<b>0.007*</b>	<b>0.018*</b>	<b>0.017</b>	<b>0.010*</b>	<b>0.024*</b>	0.004	0.001	<b>0.007</b>	<b>0.009</b>	<b>0.007</b>	<b>0.012</b>
0.001	<b>0.012</b>	<b>0.008</b>	<b>0.006*</b>	<b>0.020*</b>	0.001	0.000	0.003	-0.001	0.002	-0.004
<b>0.005*</b>	<b>0.008</b>	0.003	<b>0.007*</b>	<b>0.018*</b>	<b>0.004</b>	<b>0.004</b>	-0.004	<b>0.013*</b>	<b>0.006</b>	<b>0.011</b>
0.011	<b>0.015</b>	0.002	<b>0.012</b>	<b>0.019</b>	0.002	<b>0.006</b>	0.004	<b>0.021</b>	0.004	0.018
0.002	<b>0.012</b>	0.001	0.001	<b>0.004</b>	-0.003	<b>0.006</b>	<b>0.013</b>	0.010	<b>0.007</b>	<b>0.012</b>
0.001	0.003	0.005	0.003	<b>0.018*</b>	-0.005	-0.002	-0.001	<b>0.008</b>	0.002	0.003
0.001	<b>0.008</b>	<b>0.013</b>	0.004	<b>0.015</b>	-0.002	<b>0.007</b>	<b>0.007</b>	0.006	0.003	<b>0.005</b>
-0.002	-0.002	0.004	<b>0.009</b>	<b>0.013</b>	-0.002	-0.005	0.007	0.006	0.009	-0.004
-0.001	0.007	-0.003	-0.001	<b>0.012</b>	-0.011	-0.004	-0.006	-0.002	0.001	-0.003
-0.002	0.002	0.002	-0.005	<b>0.005</b>	-	-0.002	<b>0.001</b>	0.002	-0.002	-0.004
<b>0.004</b>	<b>0.007</b>	0.006	<b>0.006</b>	<b>0.014*</b>	<b>0.033</b>	-	<b>0.004</b>	0.005	<b>0.006</b>	0.005
-	<b>0.006</b>	<b>0.004</b>	<b>0.002</b>	<b>0.010*</b>	0.002	<b>0.008</b>	<b>0.007*</b>	<b>0.007</b>	0.004	0.002
-	-	0.004	<b>0.006</b>	<b>0.011</b>	-	-	<b>0.010</b>	<b>0.018</b>	<b>0.014</b>	<b>0.011</b>
-	-	-	<b>0.009</b>	<b>0.014</b>	-	-	0.005	<b>0.023</b>	<b>0.011</b>	0.003
0.004	-	-	-	<b>0.008</b>	0.007	<b>0.028*</b>	<b>0.006*</b>	<b>0.006</b>	<b>0.006</b>	<b>0.008</b>
0.019	-	-	<b>0.027</b>	-	<b>0.052</b>	<b>0.034</b>	<b>0.022*</b>	<b>0.019*</b>	<b>0.024*</b>	<b>0.016</b>
-	-	-	-	-	-	-	-	<b>0.008</b>	<b>0.000</b>	<b>0.007</b>
0.005	-	-	<b>0.021</b>	0.007	0.033	<b>0.005</b>	-	-	0.007	<b>0.006</b>
<b>0.007</b>	-	-	0.004	<b>0.038</b>	-0.002	0.018	<b>0.0094</b>	0.021	-	0.007
<b>0.032</b>	-	-	<b>0.037</b>	<b>0.053</b>	<b>0.063</b>	<b>0.017</b>	<b>0.0079</b>	<b>0.015</b>	0.020	-

**Table S4 Results of variation partitioning analysis for each of the three loci possibly influenced by directional selection in a global analysis. The dependent variables represent the genetic data of each of the three outlier loci. Adjusted variance components ( $R^2_{adj}$ ) with their  $p$ -values are shown, presenting the unique and shared fractions explained by environment (ENV), space (SPACE) and time (TIME) The co-variables reported are significant after forward selection has been applied: SSS = Sea Surface Salinity, SBS = Sea Bottom Salinity, SST = Sea Surface Temperature, BSS = Bottom Shear Stress,  $O_2$  = oxygen concentration, PYC = depth of pycnocline, PP = Primary Production, STRAT = stratification index, MEM = Moran Eigenvector Map, LAT = Latitude and LON = Longitude. Significant  $p$ -values are in bold ( $p < 0.05$ ). N indicates the total number of individuals included in the analysis**

	Global analysis		Global analysis		Global analysis	
	$R^2_{adj}$	$p$ -value	$R^2_{adj}$	$p$ -value	$R^2_{adj}$	$p$ -value
<b>Outliers</b>	<i>SmaUSC-E4</i>		<i>SmaUSC-E7</i>		<i>SmaI-152INRA</i>	
N	390		390		390	
Total variation	112.1		151.41		156.2	
ENV	0.136	<b>0.001</b>	0.072	<b>0.001</b>	0.069	<b>0.001</b>
SPACE	0.169	<b>0.001</b>	0.077	<b>0.001</b>	0.085	<b>0.001</b>
TIME	0.076	<b>0.001</b>	0.048	<b>0.001</b>	0.017	<b>0.002</b>
ENV + SPACE	0.163	<b>0.001</b>	0.079	<b>0.001</b>	0.082	<b>0.001</b>
ENV + TIME	0.167	<b>0.001</b>	0.084	<b>0.001</b>	0.071	<b>0.001</b>
SPACE + TIME	0.173	<b>0.001</b>	0.089	<b>0.001</b>	0.083	<b>0.001</b>
ENV+SPACE+TIME	0.159	<b>0.001</b>	0.086	<b>0.001</b>	0.082	<b>0.001</b>
ENV SPACE+TIME	-0.015	0.453	-0.003	0.556	-0.001	0.565
SPACE ENV+TIME	-0.008	0.724	0.003	0.368	0.012	0.081
TIME ENV+SPACE	-0.004	0.690	0.008	0.054	0.000	0.721
ENV TIME	0.090	<b>0.001</b>	0.036	<b>0.001</b>	0.054	<b>0.001</b>
ENV SPACE	-0.007	0.760	0.002	0.345	-0.003	0.640
SPACE TIME	0.097	<b>0.001</b>	0.041	<b>0.001</b>	0.067	<b>0.001</b>
SPACE ENV	0.027	<b>0.024</b>	0.007	0.214	0.014	0.046
TIME ENV	0.031	<b>0.003</b>	0.012	<b>0.009</b>	0.002	0.251
TIME SPACE	0.004	0.224	0.013	<b>0.016</b>	-0.001	0.601
Residuals	0.841		0.914		0.918	

		Global analysis		Global analysis		Global analysis		
		R <sup>2</sup> adj	p-value	R <sup>2</sup> adj	p-value	R <sup>2</sup> adj	p-value	
<b>Outliers</b>		<i>SmaUSC-E4</i>		<i>SmaUSC-E7</i>		<i>SmaI-152INRA</i>		
Forward selection								
ENV	SSS			0.071	<b>0.001</b>	0.047	<b>0.001</b>	
	SST	0.123	<b>0.001</b>			0.036	<b>0.001</b>	
	BSS					0.057	<b>0.006</b>	
	O2	0.052	<b>0.001</b>					
	PYC			0.077	<b>0.016</b>			
	STRAT	0.079	<b>0.001</b>					
	SBS	0.086	<b>0.048</b>					
	PP					0.063	<b>0.015</b>	
	SPACE	LAT					0.080	<b>0.025</b>
		LONG			0.050	<b>0.001</b>		
MEM1						0.023	<b>0.001</b>	
MEM2		0.059	<b>0.001</b>	0.069	<b>0.005</b>	0.068	<b>0.001</b>	
MEM3				0.060	<b>0.006</b>	0.046	<b>0.001</b>	
MEM4		0.083	<b>0.001</b>			0.075	<b>0.007</b>	
MEM8		0.109	<b>0.009</b>					
MEM10		0.096	<b>0.007</b>			0.084	<b>0.033</b>	
TIME		2003	0.079	<b>0.033</b>			0.007	<b>0.005</b>
		2007			0.039	<b>0.001</b>		
	2008					0.016	<b>0.004</b>	
	2009			0.028	<b>0.001</b>			
	2010	0.070	<b>0.001</b>	0.049	<b>0.004</b>			

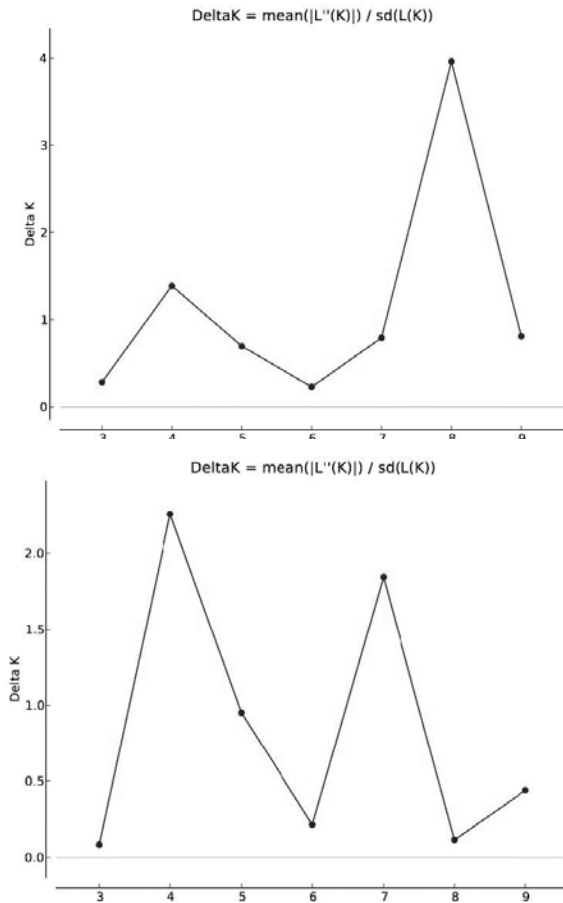

**Figure S1** Plot of delta  $K$  values obtained with STRUCTURE v 2.3.3 and according to the Evanno *et al.* (2005) method. Results are based on the mean delta  $K$  of 10 replicates for each  $K$ . A) shows the number of  $K$  for the neutral marker set, while B) displays the number of  $K$  for all 17 loci.

Based on the Evanno *et al.* (2005) method the most likely value of  $K$  is  $K = 8$ . However from a biological point of view 8 populations seem unrealistic as we were unable to pinpoint clear population units. Based on the second most likely number of clusters ( $K = 4$ ), pairwise  $F_{ST}$  estimates and biological knowledge of the species (e.g. spawning locations, life history traits), we choose the most likely  $K$  that could represent biologically meaningful populations. However, due to the hierarchical nature of structure analyses, we present STRUCTURE outputs for several  $K$  values (Figure 2).

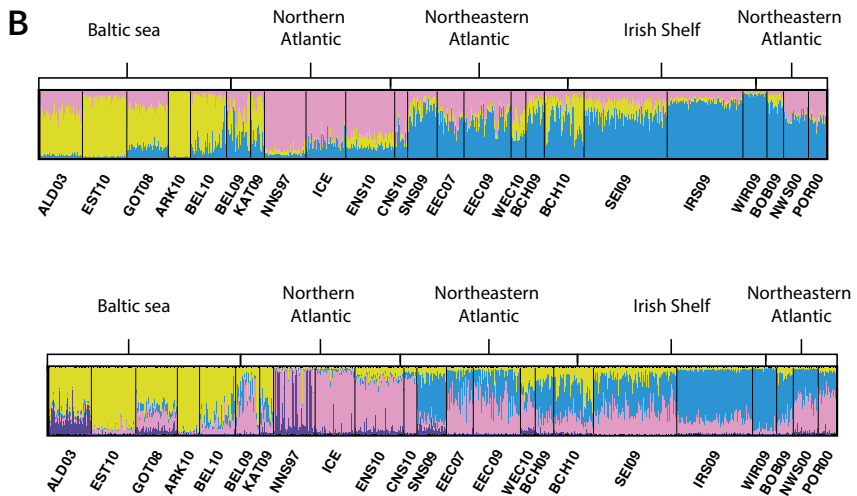
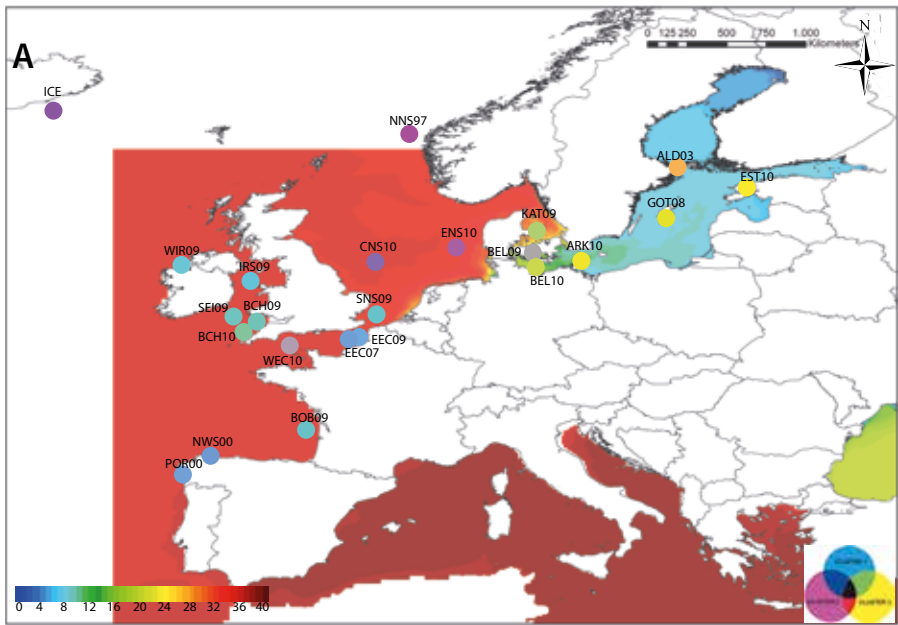

Figure S2 A) Map of sampling locations and estimated probability of cluster membership obtained from STRUCTURE analysis based on the full marker panel. Individuals belonging to the Baltic cluster (see Table 1) are mainly represented by the yellow color. Pure Irish samples (WIR, Table 1) have been appointed to the cyan color and northern North Sea samples are addressed in magenta. All other locations are represented as a mix of these three base colors based on the individual Q-values in STRUCTURE. In the background sea bottom salinity is represented for May 2007. Additional environmental parameters can be consulted for turbot at the following website: [https://fishreg.jrc.ec.europa.eu/map/genetics\\_geobrowser](https://fishreg.jrc.ec.europa.eu/map/genetics_geobrowser). B) Raw individuals cluster membership of these 17 loci for  $K$  values of 3 and 4. Samples are ordered to reflect geographical connectivity illustrated by the top brackets, underneath the figure represents the geographical origin of each sample irrespective of genetic composition. Following figure A, colours representing the genetic clusters are: yellow = Baltic Sea, pink = North-eastern Atlantic, purple = Northern Atlantic and blue = British Isles. Each bar represents an individual with its probability of membership to one of the hypothetical clusters. See Table 1 for more information on samples.





# CHAPTER 4 COMPARATIVE POPULATION GENETICS

**Table S1 Estimates of pairwise  $F_{ST}$  for all 10 microsatellites of sole (below diagonal). Significant  $p$ -values (< 0.05 above diagonal) are in bold and significant values after Bonferroni corrections are marked with an asterisk**

Region	Transition Area			North Sea				English Channel			British Isles		Iberian Peninsula
	BEL07	KAT07	SKR07	ENS07	CNS07	CNS08	SNS07	SNS08	EEC08	WEC09	BCH08	IRS08	BOB07
BEL07	-	0.600	0.672	0.827	0.278	0.055	<b>0.037</b>	0.117	0.103	0.050	<b>0.002</b>	<b>0.012</b>	<b>0.002</b>
KAT07	0.002	-	0.444	0.562	<b>0.033</b>	0.165	<b>0.001</b>	<b>0.007</b>	0.071	<b>0.001</b>	<b>0.001</b>	<b>0.001</b>	<b>0.001</b>
SKR07	0.000	0.003	-	0.465	<b>0.017</b>	0.245	<b>0.010</b>	0.110	0.301	<b>0.047</b>	<b>0.008</b>	0.061	<b>0.003</b>
ENS07	0.001	-0.001	0.001	-	0.665	0.599	0.447	0.939	0.667	0.803	<b>0.042</b>	0.592	0.106
CNS07	0.003	<b>0.002</b>	<b>0.005</b>	0.001	-	0.093	0.140	0.235	0.602	0.515	<b>0.015</b>	<b>0.016</b>	0.070
CNS08	0.007	0.003	0.004	0.003	0.004	-	0.224	0.712	0.635	0.625	<b>0.029</b>	0.564	0.328
SNS07	<b>0.005</b>	<b>0.004*</b>	<b>0.006</b>	0.003	0.000	0.000	-	0.226	0.181	0.378	<b>0.011</b>	0.074	<b>0.001</b>
SNS08	0.005	<b>0.003</b>	0.006	-0.001	-0.001	0.001	0.001	-	0.691	0.972	0.053	0.437	0.253
EEC08	0.003	0.002	0.004	0.001	-0.002	0.001	0.000	0.000	-	0.960	0.069	0.062	0.149
WEC09	0.010	<b>0.007*</b>	<b>0.009</b>	0.004	0.000	0.001	0.001	0.001	0.000	-	0.182	0.621	0.667
BCH08	<b>0.003</b>	<b>0.004</b>	<b>0.004</b>	<b>0.004</b>	<b>0.004</b>	<b>0.001</b>	<b>0.002</b>	0.002	0.001	0.001	-	0.118	<b>0.034</b>
IRS08	<b>0.007</b>	<b>0.006*</b>	0.007	0.004	<b>0.004</b>	-0.001	0.001	0.002	0.003	0.001	0.000	-	0.137
BOB07	<b>0.008</b>	<b>0.008*</b>	<b>0.008</b>	0.005	0.002	0.000	<b>0.003*</b>	0.002	0.002	0.001	<b>0.001</b>	0.001	-

**Table S2 Estimates of pairwise  $F_{ST}$  for all 14 microsatellites of brill (below diagonal). Significant  $p$ -values (< 0.05 above diagonal) are in bold and significant values after Bonferroni corrections are marked with an asterisk**

Region	Transition Area				North Sea					English Channel			
Population	BEL10	BEL09	KAT09	SKR09	ENS10	ENS09	CNS07	SNS09	SNS10	EEC07	EEC09	EEC10	WEC10
BEL10	-	0.400	0.943	0.449	0.250	0.346	0.483	0.858	0.750	0.378	0.922	0.930	0.823
BEL09	-0.002	-	0.239	0.209	0.066	0.388	<b>0.007</b>	<b>0.014</b>	0.075	<b>0.015</b>	<b>0.003</b>	<b>0.042</b>	<b>0.016</b>
KAT09	-0.008	0.004	-	0.459	0.495	0.893	0.389	0.782	0.239	0.619	0.339	0.451	0.265
SKR09	0.003	0.003	0.004	-	0.063	0.583	<b>0.047</b>	0.071	<b>0.021</b>	0.086	<b>0.040</b>	0.211	0.080
ENS10	-0.001	0.007	-0.002	0.012	-	0.991	0.313	0.724	0.721	0.457	0.094	0.688	0.545
ENS09	0.001	0.008	0.000	0.011	-0.007	-	0.870	0.672	0.633	0.811	0.850	0.683	0.780
CNS07	0.001	<b>0.008</b>	0.003	<b>0.006</b>	0.003	0.004	-	0.569	0.720	0.251	0.574	0.370	0.529
SNS09	-0.002	<b>0.006</b>	-0.001	0.007	-0.003	-0.003	0.000	-	0.325	0.219	0.888	0.697	0.657
SNS10	0.000	0.004	0.001	<b>0.011</b>	-0.002	0.004	0.001	0.000	-	0.238	0.560	0.773	0.873
EEC07	-0.003	<b>0.003</b>	0.000	0.006	0.000	0.000	0.005	0.000	0.001	-	0.243	0.846	0.514
EEC09	-0.001	<b>0.008</b>	0.002	<b>0.007</b>	0.002	-0.001	0.000	-0.001	0.002	0.002	-	0.817	0.578
EEC10	-0.004	<b>0.002</b>	0.000	0.003	0.000	0.003	0.001	0.001	-0.002	-0.004	0.000	-	0.903
WEC10	-0.003	<b>0.007</b>	0.003	0.007	0.001	-0.003	0.001	-0.002	-0.002	-0.001	-0.001	-0.003	-
BCH07	0.002	0.002	0.002	-0.003	-0.002	-0.003	0.001	-0.003	-0.002	0.000	-0.001	-0.001	-0.004
BCH09	-0.007	-0.002	-0.005	-0.001	-0.007	-0.003	0.002	-0.003	0.001	-0.003	0.001	-0.003	0.001
SEI09	-0.003	<b>0.008</b>	0.001	0.010	<b>0.005</b>	-0.001	0.003	0.002	0.003	0.001	0.001	0.001	0.000
IRS07	0.001	<b>0.009</b>	0.000	0.010	0.003	0.000	0.002	0.000	0.001	0.001	0.000	0.002	0.000
IRS09	0.000	<b>0.008</b>	-0.001	<b>0.008</b>	-0.003	-0.006	<b>0.003</b>	-0.001	0.001	0.000	0.001	0.001	0.001
WSC09	0.004	<b>0.009</b>	0.001	<b>0.014</b>	-0.001	-0.003	<b>0.005</b>	0.001	0.002	-0.003	0.003	0.000	0.003
WIR09	0.000	<b>0.009</b>	-0.001	<b>0.011</b>	0.002	0.005	<b>0.004</b>	0.002	<b>0.005</b>	0.002	0.003	0.002	0.002
BOB06	-0.001	<b>0.010</b>	0.009	<b>0.016</b>	<b>0.010</b>	0.007	<b>0.014</b>	0.007	<b>0.015</b>	0.001	0.008	<b>0.006</b>	<b>0.005</b>
BOB07	0.004	<b>0.010</b>	0.002	0.008	<b>0.001</b>	-0.003	<b>0.005</b>	-0.001	0.004	-0.001	<b>0.002</b>	0.001	<b>0.003</b>
NWS00	0.004	<b>0.011</b>	0.002	<b>0.013</b>	-0.001	-0.003	0.004	-0.003	0.001	0.001	0.003	0.001	0.001

BCH07	BCH09	British Isles					Iberian Peninsula		
		SEI09	IRS07	IRS09	WSC09	WIR09	BOB06	BOB07	NWS00
0.559	0.807	0.832	0.571	0.562	0.201	0.697	0.291	0.142	0.056
0.208	0.843	<b>0.003</b>	<b>0.002</b>	<b>0.019</b>	<b>0.020</b>	<b>0.028</b>	<b>0.028</b>	<b>0.001</b>	<b>0.004</b>
0.500	0.756	0.471	0.740	0.675	0.481	0.815	0.121	0.150	0.182
0.621	0.622	0.060	0.114	<b>0.026</b>	<b>0.036</b>	<b>0.042</b>	<b>0.021</b>	0.097	<b>0.010</b>
0.676	0.775	<b>0.003</b>	0.386	0.517	0.133	0.190	<b>0.015</b>	<b>0.041</b>	0.451
0.987	0.850	0.623	0.595	0.999	0.855	0.408	0.282	0.750	0.807
0.735	0.719	0.055	0.594	<b>0.016</b>	<b>0.038</b>	<b>0.031</b>	<b>0.005</b>	<b>0.002</b>	0.060
0.790	0.944	0.134	0.358	0.548	0.067	0.228	0.092	0.053	0.413
0.906	0.557	0.271	0.704	0.421	0.445	<b>0.022</b>	<b>0.002</b>	0.114	0.123
0.381	0.652	0.270	0.560	0.544	0.330	0.059	0.097	0.558	0.138
0.877	0.535	0.829	0.587	0.836	0.079	0.057	0.069	<b>0.034</b>	0.113
0.735	0.737	0.703	0.541	0.522	0.565	0.395	<b>0.031</b>	0.316	0.156
0.738	0.569	0.396	0.550	0.299	0.069	0.181	<b>0.033</b>	<b>0.019</b>	0.458
-	0.789	0.721	0.954	0.910	0.797	0.885	0.140	0.246	0.348
-0.002	-	0.429	0.548	0.752	0.525	0.573	<b>0.029</b>	0.178	0.218
0.001	0.001	-	0.305	0.391	0.431	0.412	0.158	<b>0.014</b>	<b>0.045</b>
-0.001	0.003	0.002	-	0.806	0.581	0.642	<b>0.006</b>	0.092	0.287
0.000	-0.003	0.001	-0.001	-	0.569	0.746	<b>0.015</b>	0.436	0.584
-0.002	-0.003	0.000	0.000	-0.004	-	0.387	0.118	0.516	0.181
-0.002	0.000	0.002	-0.001	0.000	0.001	-	0.121	<b>0.001</b>	0.299
0.008	<b>0.008</b>	0.008	<b>0.011</b>	<b>0.010</b>	0.006	0.009	-	<b>0.022</b>	<b>0.006</b>
0.001	0.002	<b>0.002</b>	0.001	-0.001	-0.006	<b>0.004</b>	<b>0.008</b>	-	0.103
0.001	0.002	<b>0.003</b>	0.000	-0.002	-0.004	-0.001	<b>0.010</b>	-0.002	-

**Table S3 Estimates of pairwise  $F_{ST}$  for all 14 microsattelites of turbot (below diagonal). Significant  $p$ -values ( $< 0.05$  above diagonal) are in bold and significant values after Bonferroni corrections are marked with an asterisk**

Region	Transition Area									North Sea									English Channel								
	BEL10	BEL09	KAT09	ENS10	CNS10	CNS07	SNS07	SNS09	EEC07	EEC09	WEC10	EEC07	EEC09	WEC10	EEC07	EEC09	WEC10	EEC07	EEC09	WEC10							
BEL10	-	0.001	0.340	0.000	0.032	0.000	0.000	0.001	0.007	0.001	0.502	0.007	0.001	0.007	0.001	0.001	0.502	0.007	0.001	0.502							
BEL09	0.007	-	0.007	0.000	0.076	0.000	0.028	0.017	0.052	0.004	0.656	0.052	0.004	0.052	0.004	0.656	0.052	0.004	0.656	0.656							
KAT09	-0.007*	0.009	-	0.001	0.274	0.000	0.034	0.058	0.004	0.456	0.477	0.004	0.456	0.477	0.004	0.456	0.477	0.004	0.456	0.477							
ENS10	0.011*	0.012*	0.004	-	0.001	0.000	0.001	0.000	0.002	0.000	0.061	0.002	0.000	0.061	0.002	0.000	0.061	0.002	0.000	0.061							
CNS10	-0.003	-0.001	-0.003	0.012	-	0.001	0.131	0.028	0.366	0.045	0.632	0.366	0.045	0.632	0.366	0.045	0.632	0.366	0.045	0.632							
CNS07	0.012*	0.010	0.006*	0.012*	0.010	-	0.111	0.001	0.129	0.000	0.169	0.129	0.000	0.169	0.129	0.000	0.169	0.129	0.000	0.169							
SNS07	0.015*	0.009	0.006	0.011	0.008	0.005	-	0.003	0.147	0.000	0.019	0.147	0.000	0.019	0.147	0.000	0.019	0.147	0.000	0.019							
SNS09	0.003	0.006	0.002	0.007*	0.006	0.008	0.006	-	0.034	0.272	0.184	0.034	0.272	0.184	0.034	0.272	0.184	0.034	0.272	0.184							
EEC07	0.000	0.003	0.001	0.007	-0.001	0.003	0.005	0.008	-	0.001	0.827	-	0.001	0.827	-	0.001	0.827	-	0.001	0.827							
EEC09	0.005	0.013	-0.004	0.014*	0.008	0.010*	0.018	0.006	0.007	-	0.179	0.007	-	0.179	0.007	-	0.179	0.007	-	0.179							
WEC10	-0.007	-0.001	-0.007	0.002	-0.008	0.004	0.016	0.005	-0.005	0.002	-	-0.005	0.002	-	-0.005	0.002	-	-0.005	0.002	-							
BCH07	0.003	0.008	0.001	0.004	-0.004	-0.005	-0.006	0.001	-0.009	0.005	-0.004	-0.009	0.005	-0.004	-0.009	0.005	-0.004	-0.009	0.005	-0.004							
BCH09	0.003	0.001	0.000	0.008	0.001	0.004	0.002	-0.003	0.008	0.002	-0.002	0.008	0.002	-0.002	0.008	0.002	-0.002	0.008	0.002	-0.002							
BCH10	0.002	0.003	-0.004	0.002	0.000	0.004	0.006	0.006	0.002	0.000	0.006	0.002	0.000	0.006	0.002	0.000	0.006	0.002	0.000	0.006							
SEI09	0.002	0.007	0.001	0.010*	0.001	0.005*	0.011	0.002	0.001	0.001	0.001	0.001	0.001	0.001	0.001	0.001	0.001	0.001	0.001	0.001							
IRS06	0.012*	0.016	-0.002	0.012*	0.012	0.008	0.015	0.012	0.012*	0.012	0.008	0.012	0.012	0.008	0.012	0.012	0.008	0.012	0.012	0.008							
IRS07	0.008	0.009	0.003	0.008	0.008	0.003	0.002	0.001	0.008	0.008	0.003	0.002	0.001	0.008	0.008	0.003	0.002	0.001	0.008	0.008							
IRS09	0.008*	0.013*	0.004	0.013*	0.006	0.007*	0.012*	0.001	0.013*	0.006	0.007*	0.012*	0.001	0.013*	0.006	0.007*	0.012*	0.001	0.013*	0.006							
WIR09	0.018*	0.020*	0.014*	0.027*	0.020*	0.018*	0.019	0.004	0.027*	0.020*	0.018*	0.019	0.004	0.027*	0.020*	0.018*	0.019	0.004	0.027*	0.020*							
BOB07	0.010*	0.009	0.003	0.016*	0.003	-0.004	0.004	0.013*	0.016*	0.003	-0.004	0.004	0.013*	0.016*	0.003	-0.004	0.004	0.013*	0.016*	0.003							
BOB09	0.012*	0.013	0.010	0.022*	-0.001	0.013	0.021	0.010	0.022*	-0.001	0.013	0.021	0.010	0.022*	-0.001	0.013	0.021	0.010	0.022*	-0.001							
NWS00	0.010*	0.004	0.004	0.012	0.002	0.006	0.004	0.007	0.012	0.002	0.006	0.004	0.007	0.012	0.002	0.006	0.004	0.007	0.012	0.002							

British Isles										Iberian Peninsula					
BCH07	BCH09	BCH10	SEI09	IRS06	IRS07	IRS09	WIR09	BOB07	BOB09	NWS00	POR00				
0.030	0.005	0.149	0.000	0.000	0.013	0.000	0.000	0.000	0.000	0.000	0.000	0.000	0.000	0.000	0.000
0.099	0.238	0.033	0.000	0.000	0.124	0.000	0.000	0.013	0.022	0.051	0.244				
0.024	0.077	0.409	0.049	0.071	0.085	0.003	0.000	0.016	0.072	0.013	0.027				
0.044	0.000	0.002	0.000	0.000	0.007	0.000	0.000	0.000	0.000	0.001	0.000				
0.507	0.122	0.332	0.183	0.010	0.035	0.017	0.000	0.060	0.099	0.074	0.547				
0.521	0.002	0.002	0.000	0.003	0.173	0.000	0.000	0.658	0.000	0.014	0.001				
0.692	0.226	0.017	0.000	0.006	0.300	0.000	0.002	0.190	0.002	0.154	0.067				
0.532	0.829	0.006	0.181	0.008	0.163	0.746	0.034	0.000	0.120	0.026	0.002				
0.945	0.423	0.100	0.073	0.071	0.204	0.088	0.000	0.256	0.002	0.197	0.085				
0.098	0.406	0.003	0.054	0.001	0.004	0.095	0.000	0.001	0.298	0.268	0.029				
0.879	0.453	0.731	0.385	0.200	0.258	0.012	0.004	0.085	0.168	0.073	0.390				
-	0.978	0.281	0.506	0.076	0.606	0.491	0.008	0.687	0.585	0.401	0.398				
-0.011	-	0.283	0.648	0.147	0.141	0.606	0.021	0.041	0.305	0.462	0.482				
-0.004	-0.002	-	0.008	0.004	0.074	0.001	0.000	0.012	0.116	0.015	0.192				
-0.001	-0.002	0.004	-	0.010	0.045	0.028	0.000	0.000	0.022	0.368	0.150				
0.007	0.002	0.007	0.006	-	0.479	0.001	0.013	0.003	0.002	0.000	0.034				
-0.003	0.002	0.006	0.004	0.004	-	0.033	0.003	0.188	0.001	0.005	0.194				
-0.001	-0.005	0.006	0.002	0.006	0.009	-	0.009	0.000	0.025	0.029	0.001				
0.012	0.005	0.014*	0.010	0.011	0.014	0.008	-	0.000	0.000	0.000	0.001				
-0.006	0.001	0.004	0.007*	0.010	0.005	0.006*	0.022*	-	0.016	0.045	0.012				
-0.002	0.002	0.005	0.007	0.018	0.023	0.006	0.019*	0.008	-	0.085	0.030				
0.001	-0.002	0.006	0.004	0.014*	0.011	0.006	0.024*	0.000	0.007	-	0.088				
-0.003	-0.004	0.005	0.002	0.011	0.003	0.008	0.016	0.007	0.006	0.007	-				

**Figure S1** PCA analyses conducted for brill on all environmental parameters. Arrows represent the individual entry of an environmental variable. The shaded triangles cluster the different averages of each variable. Abbreviations for the relevant variables are temperature of the sea surface and sea bottom (SST and SBT, respectively), salinity of the surface and bottom waters (SSS and SBS, respectively), bottom dissolved oxygen concentration ( $O_2$ ), net primary production (PP), bottom shear stress (BSS), depth of pycnocline (PYC) and stratification index (STRAT). Brill samples are represented by numbers, and three clusters are formed according to the environmental data, representing two clusters with individuals from the Skagerrak-Kattegat area, a third cluster comprises all other Northeast Atlantic samples.

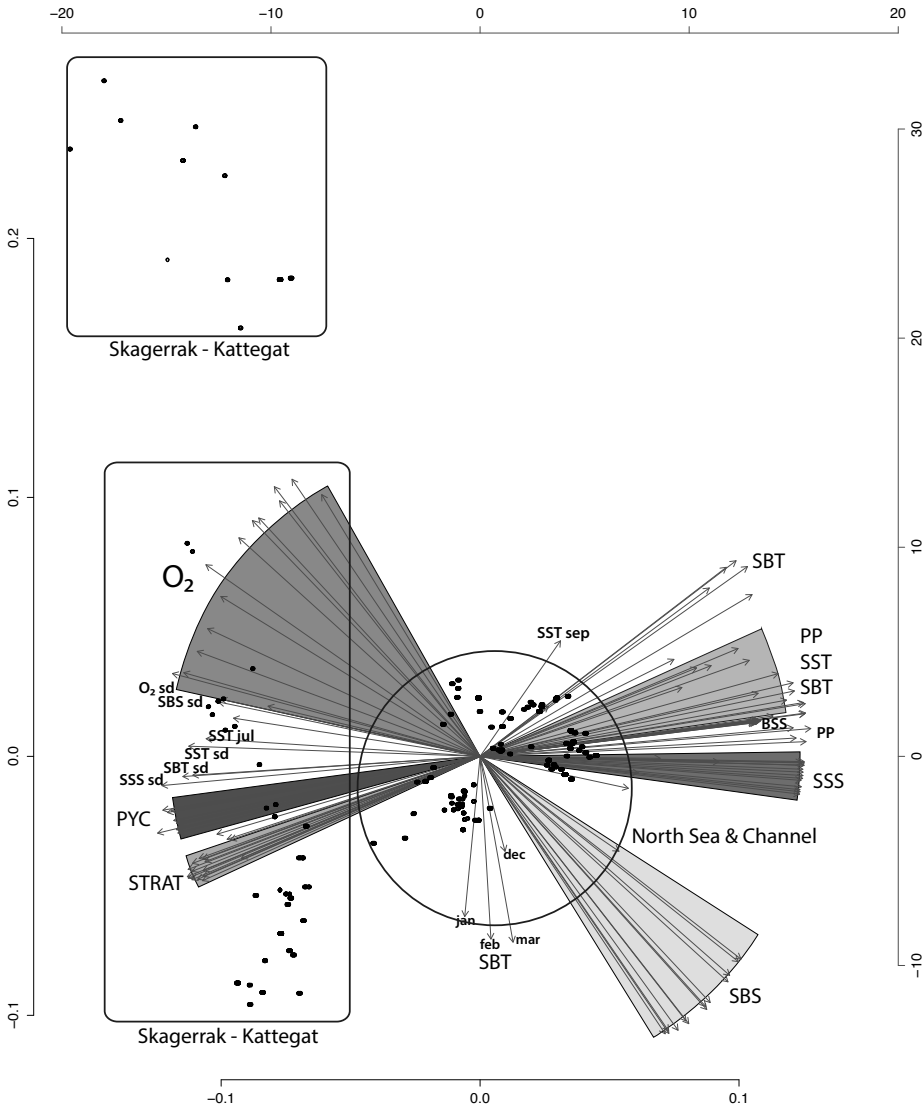

**Figure S2** PCA analyses for sole identifies 4 clusters of individuals, the relevant areas are indicated next to the circles. Monthly, yearly averages or the standard deviation of an environmental variable is represented by their abbreviations: temperature of the sea surface and sea bottom (SST and SBT, respectively), salinity of the surface and bottom waters (SSS and SBS, respectively), bottom dissolved oxygen concentration (O<sub>2</sub>), net primary production (PP), bottom shear stress (BSS), depth of pycnocline (PYC) and stratification index (STRAT).

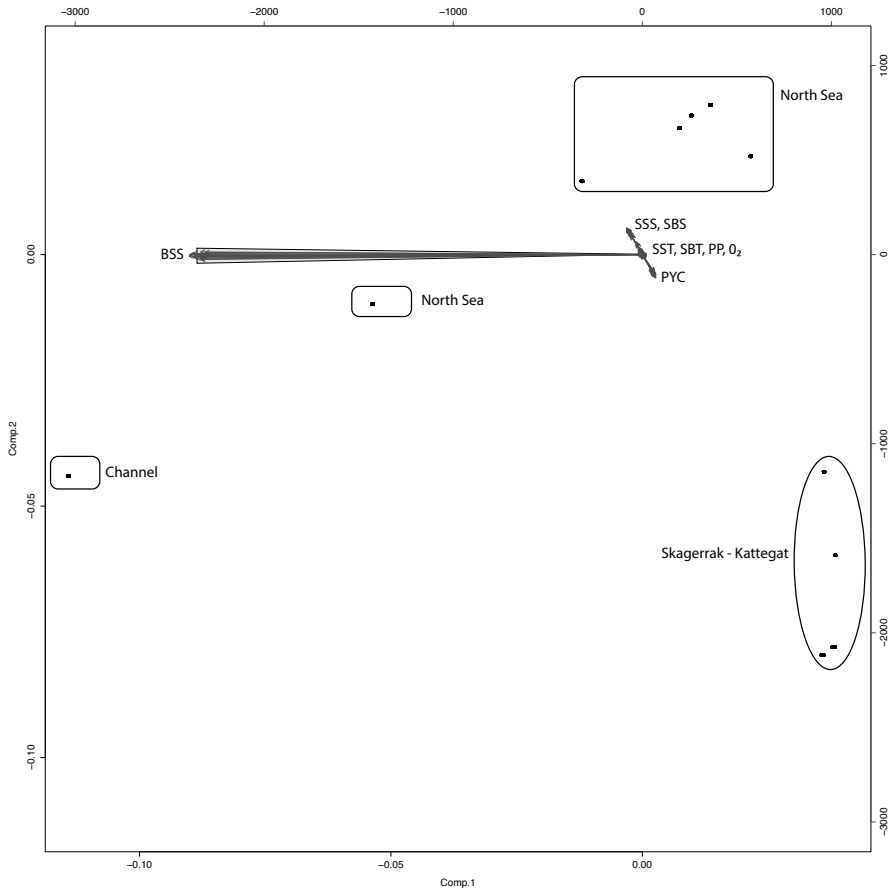





# References



# References

- Abella A, Fiorentino F, Mannini A, Orsi Relini L (2008) Exploring relationships between recruitment of European hake (*Merluccius merluccius* L. 1758) and environmental factors in the Ligurian Sea and the Strait of Sicily (Central Mediterranean). *Journal of Marine Systems*, 71, 279-293.
- Agnew DJ, Pearce J, Pramod G, *et al.* (2009) Estimating the Worldwide Extent of Illegal Fishing. *PLoS ONE*, 4, e4570.
- Allen PM, McGlade JM (1987) Modelling complex human systems: A fisheries example. *European Journal of Operational Research*, 30, 147-167.
- Allendorf FW, England PR, Luikart G, Ritchie PA, Ryman N (2008) Genetic effects of harvest on wild animal populations. *Trends in ecology & evolution (Personal edition)*, 23, 327-337.
- Allison EH, Ratner BD, Åsgård B, *et al.* (2012) Rights-based fisheries governance: from fishing rights to human rights. *Fish and Fisheries*, 13, 14-29.
- Almada VC, Almada F, Francisco SM, Castilho R, Robalo JI (2012) Unexpected high genetic diversity at the extreme northern geographic limit of *Taurulus bubalis* (Euphrasen, 1786). *PLoS ONE*, 7, e44404.
- Aneer G, Westin L (1990) Migration of turbot (*Psetta maxima* L) in the Northern Baltic proper. *Fisheries Research*, 9, 307-315.
- Antao T, Lopes A, Lopes R, Beja-Pereira A, Luikart G (2008) LOSITAN: A workbench to detect molecular adaptation based on a Fst-outlier method. *BMC Bioinformatics*, 9, 1-5.
- Anticamara JA, Watson R, Gelchu A, Pauly D (2011) Global fishing effort (1950-2010): Trends, gaps and implications. *Fisheries Research*, 107, 131-136.
- Arbogast BS, Slowinski JB (1998) Pleistocene speciation and the mitochondrial DNA clock. *Science*, 282, 1955.
- Árnason T, Björnsson B, Steinarsson A, Oddgeirsson M (2009) Effects of temperature and body weight on growth rate and feed conversion ratio in turbot (*Scophthalmus maximus*). *Aquaculture*, 295, 218-225.
- Arnold GP, Metcalfe JD (1995) Seasonal migrations of plaice (*Pleuronectes platessa*) through the Dover Strait. *Marine Biology*, 127, 151-160.
- Audzijonyte A, Kuparinen A, Fulton EA (2013) How fast is fisheries-induced evolution? Quantitative analysis of modelling and empirical studies. *Evolutionary Applications*, 6, 585-595.
- Avise JC, Walker D, Johns GC (1998) Speciation durations and Pleistocene effects on vertebrate phylogeography. *Proceedings of the Royal Society of London. Series B: Biological Sciences*, 265, 1707-1712.
- Avise JC (2000) *Phylogeography: the history and formation of species*. Harvard University Press Cambridge MA, 1, pp. 447.
- Azevedo MFC, Oliveira C, Pardo BG, Martinez P, Foresti F (2008) Phylogenetic analysis of the order Pleuronectiformes (Teleostei) based on sequences of 12S and 16S mitochondrial genes. *Genetics and Molecular Biology*, 31, 284-292.
- Azzurro E, Moschella P, Maynou F (2011) Tracking Signals of Change in Mediterranean Fish Diversity Based on Local Ecological Knowledge. *PLoS ONE*, 6, e24885.
- Bailey N, Chanet B (2010) *Scophthalmus Rafinesque*, 1810: The valid generic name for the turbot (*S. maximus*) (Linnaeus, 1758) Pleuronectiformes: Scophthalmidae. *Cybio*, 34, 257-261.
- Bargelloni L, Alarcon JA, Alvarez MC, *et al.* (2003) Discord in the family Sparidae (Teleostei): divergent phylogeographical patterns across the Atlantic-Mediterranean divide. *Journal of Evolutionary Biology*, 16, 1149-1158.
- Bargelloni L, Alarcon JA, Alvarez MC, *et al.* (2005) The Atlantic-Mediterranean transition: Discordant genetic patterns in two seabream species, *Diplodus puntazzo* (Cetti) and *Diplodus sargus* (L.). *Molecular Phylogenetics and Evolution*, 36, 523-535.
- Barnes R (2006) The convention on the law of the sea: An effective framework for domestic fisheries conservation? In: *The Law of the Sea* (ed. Freestone D, Barnes, R. and Ong, D.M.), pp. 233-260. Oxford University Press, Oxford.
- Bartolino V, Ciannelli L, Spencer P, Wilderbuer TK, Chan KS (2012) Scale-dependent detection of the effects of harvesting a marine fish population. *Marine Ecology Progress Series*, 444, 251-261.
- Beaumont MA, Nichols RA (1996) Evaluating loci for use in the genetic analysis of population structure. *Proceedings of the Royal Society of London Series B-Biological Sciences*, 263, 1619-1626.
- Beaumont M (2004) Recent developments in genetic data analysis: what can they tell us about human demographic history? *Heredity*, 92, 365-379.

- Becker GA (1990) Die Nordsee als physikalisches System. In: Warnsignale aus der Nordsee: Wissenschaftliche Fakten (eds. Lozán JL, Lenz W, Rachor E, Watermann B, Westerhagen H), pp. 11-27.
- Beebee TJC, Rowe G (2008) An introduction to molecular ecology. Oxford University Press, Oxford.
- Bernstein S, Cashore B (2000) Globalization, four paths of internationalization and domestic policy change: the case of ecoforestry in British Columbia, Canada. *Canadian Journal of Political Science/Revue canadienne de science politique*, 33, 67-99.
- Betancur R, Li C, Munroe TA, Ballesteros JA, Ortí G (2013) Addressing gene tree discordance and non-stationarity to resolve a multi-locus phylogeny of the flatfishes (Teleostei: Pleuronectiformes). *Systematic Biology*, 1-67.
- Beyst B, Cattrijsse A, Mees J (1999) Feeding ecology of juvenile flatfishes of the surf zone of a sandy beach. *Journal of Fish Biology*, 55, 1171-1186.
- Beyst B, Hostens K, Mees J (2001) Factors influencing fish and macrocrustacean communities in the surf zone of sandy beaches in Belgium: temporal variation. *Journal of Sea Research*, 46, 281-294.
- Bianchi G, Skjoldal HR (2008) The ecosystem approach to fisheries. FAO and CABI Publishing, UK.
- Bierne N (2010) The distinctive footprints of local hitchhiking in a varied environment and global hitchhiking in a subdivided population. *Evolution*, 64, 3254-3272.
- Bierne N, Welch J, Loire E, Bonhomme F, David P (2011) The coupling hypothesis: why genome scans may fail to map local adaptation genes. *Molecular Ecology*, 20, 2044-2072.
- Birkland T (2001) An introduction to the policy process: theories, concepts, and models of public policy making. M.E. Sharpe, Armonk, NY.
- Blanchet FG, Legendre P, Borcard D (2008) Forward selection of explanatory variables. *Ecology*, 89, 2623-2632.
- Blanchet S, Rey O, Etienne R, Lek S, Looft G (2010) Species-specific responses to landscape fragmentation: implications for management strategies. *Evolutionary Applications*, 3, 291-304.
- Blyth-Skyrme RE, Kaiser MJ, Hiddink JG, Edwards-Jones G, Hart PJB (2006) Conservation benefits of temperate marine protected areas: variation among fish species. *Conservation Biology*, 20, 811-820.
- Boeuf G, Payan P (2001) How should salinity influence fish growth? *Comparative Biochemistry and Physiology C-Toxicology & Pharmacology*, 130, 411-423.
- Bollmann M, Bosch T, Colijn F, *et al.* (2010) World ocean review- Living with the oceans. pp. 232.
- Bonin A, Bellemain E, Bronken Eidsen P, *et al.* (2004) How to track and assess genotyping errors in population genetics studies. *Molecular Ecology*, 13, 3261-3273.
- Borcard D, Legendre P (2002) All-scale spatial analysis of ecological data by means of principal coordinates of neighbour matrices. *Ecological Modelling*, 153, 51-68.
- Borcard D, Gillet F, Legendre P (2011) Numerical ecology with R. Springer New York.
- Bourlat SJ, Borja A, Gilbert J, *et al.* (2013) Genomics in marine monitoring: New opportunities for assessing marine health status. *Marine Pollution Bulletin*, 74, 19-31.
- Bouza C, Presa P, Castro J, Sanchez L, Martinez P (2002) Allozyme and microsatellite diversity in natural and domestic populations of turbot (*Scophthalmus maximus*) in comparison with other Pleuronectiformes. *Canadian Journal of Fisheries and Aquatic Sciences*, 59, 1460-1473.
- Bouza C, Hermida M, Millan A, *et al.* (2008) Characterization of EST-derived microsatellites for gene mapping and evolutionary genomics in turbot. *Animal Genetics*, 39, 666-670.
- Boyle A (2006) Further development of the 1982 convention on the law of the sea: mechanisms for change. 'Oxford University Press'.
- Bradbury IR, Bentzen P (2007) Non-linear genetic isolation by distance: implications for dispersal estimation in anadromous and marine fish populations. *Marine Ecology Progress Series*, 340, 245-257.
- Bradbury IR, Hubert S, Higgins B, *et al.* (2010) Parallel adaptive evolution of Atlantic cod on both sides of the Atlantic Ocean in response to temperature. *Proceedings of the Royal Society B: Biological Sciences*, 277, 3725-3734.
- Bradbury IR, Hubert S, Higgins B, *et al.* (2013) Genomic islands of divergence and their consequences for the resolution of spatial structure in an exploited marine fish. *Evolutionary Applications*, 6, 450-461.
- Branch TA, Austin JD, Acevedo-Whitehouse K, *et al.* (2012) Fisheries conservation and management: finding consensus in the midst of competing paradigms. *Animal Conservation*, 15, 1-3.
- Brans M, Ferraro G (2011) Policy reforms and the politics of nature. The case of marine fisheries in China and Senegal. In: *Journal of Comparative Policy Analysis: Research and Practice*, pp. 9-25.
- Brans M, Ferraro G (2012) International agreements and the salience of domestic politics: Locus, Focus and Gradus. The case of fisheries policy reforms in China and Senegal. *Journal of Comparative Policy Analysis: Research and Practice*, 14, 9-25.
- Breitmeier H, Young OR, Züm M (2006) Analyzing international environmental regimes - from case study to database. The MIT Press, Cambridge and London.

- Briand G, Heckelei T, Matulich SC, Mittelhammer RC (2004) Managing fishing power: the case of Alaska red king crab (*Paralithodes camtschaticus*). *Canadian Journal of Fisheries and Aquatic Sciences*, 61, 43-53.
- Briggs JC, Bowen BW (2012) A realignment of marine biogeographic provinces with particular reference to fish distributions. *Journal of Biogeography*, 39, 12-30.
- Browman HI, Stergiou KI (2005) Politics and socio-economics of ecosystem-based management of marine resources. *Molecular ecology progress series*, 300, 241-248.
- Brown V, Gutknecht J, Harden L, *et al.* (2010) Understanding and engaging values in policy relevant science. *Bulletin of the British Ecological Society*, 41, 48-56.
- Buanes A, Jentoft S (2009) Building bridges: Institutional perspectives on interdisciplinarity. *Futures*, 41, 446-454.
- Buck SJ (1998) *The Global commons-an introduction*. Earthscan, London.
- Caddy JF, Cochrane KL (2001) A review of fisheries management past and present and some future perspectives for the third millennium. *Ocean & Coastal Management*, 44, 653-682.
- Cadrin SX (2010) Interdisciplinary analysis of yellowtail flounder stock structure off New England. *Reviews in Fisheries Science*, 18, 281-299.
- Cadrin S, Kerr LA, Mariani S (2013) *Stock identification methods, 2nd edition- Applications in fisheries science*. Academic Press.
- Campo D, Garcia-Vazquez E (2010) Evolutionary history of the four-spotted megrim (*Lepidorhombus boscii*) and speciation time within the genus based on mitochondrial genes analysis. *Journal of Sea Research*, 64, 360-368.
- Cantatore P, Roberti M, Pesole G, *et al.* (1994) Evolutionary analysis of cytochrome b sequences in some perciformes: Evidence for a slower rate of evolution than in mammals. *Journal of Molecular Evolution*, 39, 589-597.
- Capella-Gutiérrez S, Silla-Martinez JM, Gabaldón T (2009) trimAl: a tool for automated alignment trimming in large-scale phylogenetic analyses. *Bioinformatics*, 25, 1972-1973.
- Cardinale M, Svedäng H (2004) Modelling recruitment and abundance of Atlantic cod, *Gadus morhua*, in the eastern Skagerrak-Kattegat (North Sea): evidence of severe depletion due to a prolonged period of high fishing pressure. *Fisheries Research*, 69, 263-282.
- Cardinale M, Linder M, Bartolino V, Maiorano L, Casini M (2009) Conservation value of historical data: reconstructing stock dynamics of turbot during the last century in the Kattegat-Skagerrak. *Marine Ecology Progress Series*, 386, 197-206.
- Cardinale M, Hagberg J, Svedäng H, *et al.* (2010) Fishing through time: population dynamics of plaice (*Pleuronectes platessa*) in the Kattegat-Skagerrak over a century. *Population Ecology*, 52, 251-262.
- Cardinale M, Bartolino V, Llope M, *et al.* (2011) Historical spatial baselines in conservation and management of marine resources. *Fish and Fisheries*, 12, 289-298.
- Cardinale M, Dörner H, Abella A, *et al.* (2013) Rebuilding EU fish stocks and fisheries, a process under way? *Marine Policy*, 39, 43-52.
- Cash DW, Clark WC, Alcock F, *et al.* (2003) Knowledge systems for sustainable development. *Proceedings of the National Academy of Sciences*, 100, 8086-8091.
- Castilla JC, Defeo O (2005) Paradigm shifts needed for world fisheries. *Science*, 309, 1324-1325.
- Chanet B (2003) Interrelationships of Scophthalmid fishes (Pleuronectiformes : Scophthalmidae). *Cybiurn*, 27, 275-286.
- Charles AT (2001) *Sustainable fishery systems*. Blackwell Science, Oxford.
- Charrier G, Chenel T, Durand JD, *et al.* (2006) Discrepancies in phylogeographical patterns of two European anglerfishes (*Lophius budegassa* and *Lophius piscatorius*). *Molecular Phylogenetics and Evolution*, 38, 742-754.
- Charrier G, Coombs SH, McQuinn IH, Laroche J (2007) Genetic structure of whiting (*Merlangius merlangus*) in the northeast Atlantic and adjacent waters. *Marine Ecology-Progress Series*, 330, 201-211.
- Chen J, Rossiter SJ, Flanders JR, *et al.* (2010) Contrasting genetic structure in two co-distributed species of old world fruit bat. *PLoS ONE*, 5, e13903.
- Cheung WWL, Lam VWY, Sarmiento JL, *et al.* (2009) Projecting global marine biodiversity impacts under climate change scenarios. *Fish and Fisheries*, 10, 235-251.
- Chevolot M, Ellis JR, Rijnsdorp AD, Stam WT, Olsen JL (2008) Temporal changes in allele frequencies but stable genetic diversity over the past 40 years in the Irish Sea population of thornback ray (*Raja clavata*). *Heredity*, 101, 120-126.
- Choucri N, North RC (1993) Growth, development and environmental sustainability: profile and paradox. In: *Global Accord - Environmental Challenges and International Responses* (ed. Choucri N.), pp. 67-132. The MIT Press, Cambridge (Massachusetts) and London.
- Churchill R, Owen D (2010) *The EC common fisheries policy*. Oxford University Press.

- Clement M, Posada D, Crandall KA (2000) TCS: a computer program to estimate gene genealogies. *Molecular Ecology*, 9, 1657-1659.
- Coll  ter M, Gascuel D, Ecoutin J-M, Tito de Morais L (2012) Modelling trophic flows in ecosystems to assess the efficiency of marine protected area (MPA), a case study on the coast of S  n  gal. *Ecological Modelling*, 232, 1-13.
- COM 275 f (2006) Towards a future Maritime Policy for the oceans and seas. (ed. Communities E), pp. 58. Office for Official Publications of the European Communities, Luxembourg.
- COM 575 f (2007) An Integrated Maritime Policy for the European Union and action plan [SEC (2007) 1278].
- COM 163 f (2009) GREEN PAPER reform of the common fisheries policy. (ed. Commission E), pp. 28.
- COM 425 f (2011) Proposal for a regulation of the European Parliament and of the Council on the Common Fisheries Policy. (ed. Commission E), pp. 85.
- COM 804 f (2011) Regulation of the European Parliament and of the Council on the European Maritime and Fisheries Fund (repealing Council Regulation (EC) No 1198/2006 and Council Regulation (EC) No 861/2006 and Council Regulation No XXX/2011 on integrated maritime policy (ed. Commission E), pp. 158, Brussels.
- COM 278 f (2012) Communication from the Commission to the Council concerning a consultation on fishing opportunities for 2013. (ed. Commission E), pp. 17, Brussel.
- Conover DO, Clarke LM, Munch SB, Wagner GN (2006) Spatial and temporal scales of adaptive divergence in marine fishes and the implications for conservation. *Journal of Fish Biology*, 69, 21-47.
- Coop G, Witonsky D, Di Rienzo A, Pritchard JK (2010) Using environmental correlations to identify loci underlying local adaptation. *Genetics*, 185, 1411-1423.
- Cordier M, P  rez Ag  ndez JA, O'Connor M, Rochette S, Hecq W (2011) Quantification of interdependencies between economic systems and ecosystem services: An input-output model applied to the Seine estuary. *Ecological Economics*, 70, 1660-1671.
- Cordue PL (2007) A note on non-random error structure in trawl survey abundance indices. *ICES Journal of Marine Science: Journal du Conseil*, 64, 1333-1337.
- Cornuet J-M, Santos F, Beaumont MA, *et al.* (2008) Inferring population history with DIY ABC: a user-friendly approach to approximate Bayesian computation. *Bioinformatics*, 24, 2713-2719.
- Cornuet J-M, Ravigne V, Estoup A (2010) Inference on population history and model checking using DNA sequence and microsatellite data with the software DIYABC (v1.0). *BMC Bioinformatics*, 11, 401.
- Coscia I, Vogiatzi E, Kotoulas G, Tsigenopoulos CS, Mariani S (2012) Exploring neutral and adaptive processes in expanding populations of gilthead sea bream (*Sparus aurata* L.), in the North-East Atlantic. *Heredity*, 108, 537-546.
- Coscia I, McDevitt AD, King JJ, *et al.* (2013) A species-to-be? The genetic status and colonization history of the critically endangered Killarney shad. *Molecular Phylogenetics and Evolution*, 69, 1190-1195.
- Costello C, Ovando D, Hilborn R, *et al.* (2012) Status and solutions for the world's unassessed fisheries. *Science*, 338, 517-520.
- Coughlan J, McCarthy E, McGregor D, *et al.* (1996) Four polymorphic microsatellites in turbot (*Scophthalmus maximus*). *Animal Genetics*, 27, 441-444.
- Coughlan JP, Imsland AK, Galvin PT, *et al.* (1998) Microsatellite DNA variation in wild populations and farmed strains of turbot from Ireland and Norway: a preliminary study. *Journal of Fish Biology*, 52, 916-922.
- Council (2013) Basic regulation on the CFP - Final Compromise Text (14.6.2013). pp. 93.
- Cowen RK, Paris CB, Srinivasan A (2006) Scaling of connectivity in marine populations. *Science*, 311, 522-527.
- Cowen RK, Sponaugle S (2009) Larval dispersal and marine population connectivity. *Annual Review of Marine Science*, 1, 443-466.
- Crowder L, Norse E (2008) Essential ecological insights for marine ecosystem-based management and marine spatial planning. *Marine Policy*, 32, 772-778.
- Crowder LB, Hazen EL, Avissar N, *et al.* (2008) The Impacts of Fisheries on Marine Ecosystems and the Transition to Ecosystem-Based Management. *Annual Review of Ecology, Evolution, and Systematics*, 39, 259-278.
- Cushing DH (1990) Hydrographic containment of a spawning group of plaice in the southern bight of the North Sea. *Marine Ecology Progress Series*, 58, 287-297.
- Cuveliers EL, Volckaert FAM, Rijnsdorp AD, Larmuseau MHD, Maes GE (2011) Temporal genetic stability and high effective population size despite fisheries-induced life-history trait evolution in the North Sea sole. *Molecular Ecology*, 20, 3555-3568.
- Cuveliers E, Larmuseau M, Hellemans B, *et al.* (2012) Multi-marker estimate of genetic connectivity of sole (*Solea solea*) in the North-East Atlantic Ocean. *Marine Biology*, 159, 1239-1253.
- D'Onghia G, Giove A, Maiorano P, *et al.* (2012) Exploring relationships between demersal resources and environmental factors in the Ionian Sea (Central Mediterranean). *Journal of Marine Biology*, 2012, 12.

- Daan N, Bromley PJ, Hislop JRG, Nielsen NA (1990) Ecology of North Sea fish. *Netherlands Journal of Sea Research*, 26, 343-386.
- Danancher D, Garcia-Vazquez E (2009) Population differentiation in megrim (*Lepidorhombus whiffiagonis*) and four spotted megrim (*Lepidorhombus boscii*) across Atlantic and Mediterranean waters and implications for wild stock management. *Marine Biology*, 156, 1869-1880.
- Danancher D, Garcia-Vazquez E (2011) Genetic population structure in flatfishes and potential impact of aquaculture and stock enhancement on wild populations in Europe. *Reviews in Fish Biology and Fisheries*, 21, 441-462.
- Dankel DJ, Aps R, Padda G, *et al.* (2012) Advice under uncertainty in the marine system. *ICES Journal of Marine Science: Journal du Conseil*, 69, 3-7.
- Dann TH, Habicht C, Baker TT, Seeb JE (2013) Exploiting genetic diversity to balance conservation and harvest of migratory salmon. *Canadian Journal of Fisheries and Aquatic Sciences*, 70, 785-793.
- Daw T, Gray T (2005) Fisheries science and sustainability in international policy: a study of failure in the European Union's common fisheries policy. *Marine Policy*, 29, 189-197.
- Dawson MN, Louie KD, Barlow M, Jacobs DK, Swift CC (2002) Comparative phylogeography of sympatric sister species, *Clevendia iolas* and *Eucyclogobius newberryi* (Teleostei, Gobiidae), across the California Transition Zone. *Molecular Ecology*, 11, 1065-1075.
- De Santo EM (2010) 'Whose science?' Precaution and power-play in European marine environmental decision-making. *Marine Policy*, 34, 411-420.
- Debes PV, Zachos FE, Hanel R (2008) Mitochondrial phylogeography of the European sprat (*Sprattus sprattus* L., Clupeidae) reveals isolated climatically vulnerable populations in the Mediterranean Sea and range expansion in the northeast Atlantic. *Molecular Ecology*, 17, 3873-3888.
- DeFaveri J, Jonsson PR, Merilä J (2013) Heterogeneous genomic differentiation in marine threespine sticklebacks: adaptation along an environmental gradient. *Evolution*, 67, 2530-2546.
- Degnol P, Gislason H, Hanna S, *et al.* (2006) Painting the floor with a hammer: Technical fixes in fisheries management. *Marine Policy*, 30, 534-543.
- Delavenne J (2012) Conservation of marine habitats under multiple human uses. Methods, objectives and constraints to optimize a Marine Protected Areas network in the eastern English Channel., l'Université du Littoral Côte d'Opale.
- Delbare D, De Clerck R (1999) Stock discrimination in relation to the assessment of the brill fishery-study in support of the common fisheries policy. Final Report EC-study Contract DG XIV 96-001. pp.36.
- Dénél C (1981) Les poissons plats (Téléostéens-Pleuronectiformes) en Baie de Douarnenez: Reproduction, croissance et migration des Bothidae, Scophthalmidae, Pleuronectidae et Soleidae. In: PhD Thesis, pp. 1-476. Université de Bretagne Occidentale, Brest, Université de Bretagne Occidentale, Brest.
- Devauchelle N, Alexandre JC, Le Corre N, Letty Y (1988) Spawning of turbot (*Scophthalmus maximus*) in captivity. *Aquaculture*, 69, 159-184.
- DeWoody JA, Avise JC (2000) Microsatellite variation in marine, freshwater and anadromous fishes compared with other animals. *Journal of Fish Biology*, 56, 461-473.
- DG MARE (2012) Roadmap: Proposal for a regulation of the European parliament and of the Council introducing a discard ban in the Skagerrak. *Politics*, pp. 4.
- Dichmont CM, Ovenden JR, Berry O, Welch DJ, Buckworth RC (2012) Scoping current and future genetic tools, their limitations and their applications for wild fisheries management. pp. 129.
- Dinmore TA, Duplisea DE, Rackham BD, Maxwell DL, Jennings S (2003) Impact of a large-scale area closure on patterns of fishing disturbance and the consequences for benthic communities. *ICES Journal of Marine Science: Journal du Conseil*, 60, 371-380.
- Directive 2008/56/EC of 17 June 2008 establishing a framework for community action in the field of marine environmental policy (Marine Strategy Framework Directive). pp. 22.
- Dormann CF, McPherson JM, Araújo MB, *et al.* (2007) Methods to account for spatial autocorrelation in the analysis of species distributional data: a review. *Ecography*, 30, 609-628.
- Dray S, Legendre P, Blanchet FG (2007) Forward selection with permutation. R package version 0.0-9. [http://r-forge.r-project.org/R/group\\_id=195](http://r-forge.r-project.org/R/group_id=195).
- Dray S, Pélissier R, Couteron P, *et al.* (2012) Community ecology in the age of multivariate multiscale spatial analysis. *Ecological Monographs*, 82, 257-275.
- Drummond AJ, Rambaut A, Shapiro B, Pybus OG (2005) Bayesian coalescent inference of past population dynamics from molecular sequences. *Molecular Biology and Evolution*, 22, 1185-1192.
- Dulvy NK, Jennings S, Goodwin NB, Grant A, Reynolds JD (2005) Comparison of threat and exploitation status in North-East Atlantic marine populations. *Journal of Applied Ecology*, 42, 883-891.

- Dunn MR, Pawson MG (2002) The stock structure and migrations of plaice populations on the west coast of England and Wales. *Journal of Fish Biology*, 61, 360-393.
- Earl D, vonHoldt B (2012) STRUCTURE HARVESTER: a website and program for visualizing STRUCTURE output and implementing the Evanno method. *Conservation Genetics Resources*, 4, 359-361.
- EC (2011) Reform of the Common Fisheries Policy. EC, pp. 11.
- El Mousadik A, Petit RJ (1996) High level of genetic differentiation for allelic richness among populations of the argan tree (*Argania spinosa* (L.) Skeels) endemic to Morocco. *Theoretical and Applied Genetics*, 92, 832-839.
- Elshire RJ, Glaubitz JC, Sun Q, et al. (2011) A robust, simple genotyping-by-sequencing (GBS) approach for high diversity species. *PLoS ONE*, 6, e19379.
- Enberg K, Jørgensen C, Dunlop ES, Heino M, Dieckmann U (2009) Implications of fisheries-induced evolution for stock rebuilding and recovery. *Evolutionary Applications*, 2, 394-414.
- Engelhard GH, Pinnegar JK, Kell LT, Rijnsdorp AD (2011) Nine decades of North Sea sole and plaice distribution. *ICES Journal of Marine Science: Journal du Conseil*, 68, 1090-1104.
- Espiñeira M, González-Lavin N, Vieites JM, Santaclara FJ (2008) Development of a method for the genetic identification of flatfish species on the basis of mitochondrial DNA sequences. *Journal of agricultural and food chemistry*, 56, 8954-8961.
- Estoup A, Gharbi K, SanCristobal M, et al. (1998) Parentage assignment using microsatellites in turbot (*Scophthalmus maximus*) and rainbow trout (*Oncorhynchus mykiss*) hatchery populations. *Canadian Journal of Fisheries and Aquatic Sciences*, 55, 715-725.
- Etzkowitz H, Leydesdorff L (2000) The dynamics of innovation: from National Systems and "Mode 2" to a Triple Helix of university-industry-government relations. *Research Policy*, 29, 109-123.
- European Commission (2005) Commission decision of 26 August 2005 establishing a Scientific, Technical and Economic Committee for Fisheries (2005/629/EC), pp. 5. Official Journal of the European Union, Brussels.
- European Commission (2009) The common fisheries policy. A user's guide., pp. 36. Luxembourg office for official publications of the European Communities, Belgium.
- European Commission (2011) 36th Plenary meeting report of the scientific, technical and economic committee for fisheries (PLEN-11-01). Joint Research Centre, pp. 80.
- European Commission (2012) The European Union explained- How the European Union works, pp. 44.
- European Commission (2013) Roadmap: Proposal for a regulation amending the technical measures and control regulations to implement the landing obligation. AP. 2013/MARE/108. DG MARE-unit 2, pp. 8.
- European Communities (2002) Council Regulation (EC) No 2371/2002 of December 2002 on the conservation and sustainable exploitation of fisheries resources under the Common Fisheries Policy, pp. 22. Official Journal of the European Communities.
- European Communities (2008a) Commission Regulation (EC) No 665/2008 of 14 July 2008. Laying down detailed rules for the application of Council Regulation (EC) No 199/2008 concerning the establishment of a Community framework for the collection, management and use of data in the fisheries sector and support for scientific advice regarding the Common Fisheries Policy, pp. 3. Official Journal of the European Communities.
- European Communities (2008b) Council Regulation (EC) No 199/2008 of 25 February 2008 concerning the establishment of a Community framework for the collection, management and use of data in the fisheries sector and support for scientific advice regarding the Common Fisheries Policy, pp. 12. Official Journal of the European Communities.
- European Communities (2008c) Council Regulation (EC) No 1342/2008 of 18 December 2008 establishing a long-term plan for cod stocks and the fisheries exploiting those stocks and repealing Regulation (EC) No 423/2004, pp. 14. Official Journal of the European Communities.
- European Council (2013) Basic regulation on the CFP - Final Compromise Text (14.6.2013), pp. 93.
- European Marine Board (2013) Navigating the Future IV. Position Paper 20 of the European Marine Board, pp. 207.
- European Parliament's Committee on Fisheries (2007) Rights based management in fisheries. European Parliament, pp. 84.
- European Union (2008) Consolidated version of the Treaty on the functioning of the European Union. Official Journal of the European Union 9.5.2008, pp. 153.
- European Union (2012) Consolidated version of the Treaty on the functioning of the European Union (TFEU). Official Journal of the European Union C326/47.
- Evanno G, Regnaut S, Goudet J (2005) Detecting the number of clusters of individuals using the software STRUCTURE: a simulation study. *Molecular Ecology*, 14, 2611-2620.
- Evans TG, Hofmann GE (2012) Defining the limits of physiological plasticity: how gene expression can assess and predict the consequences of ocean change. *Philosophical Transactions of the Royal Society B: Biological Sciences*, 367, 1733-1745.



- Excoffier L, Lischer HEL (2010) Arlequin suite ver 3.5: a new series of programs to perform population genetics analyses under Linux and Windows. *Molecular Ecology Resources*, 10, 564-567.
- Falkner G, Hartlapp M, Leiber S, Treib O (2004) Non-compliance with EU directives in the member states: Opposition through the backdoor? *West European Politics*, 27, 452-473.
- FAO (1997) Fisheries Management. FAO, pp. 121.
- FAO (2002) A fishery manager's guidebook. Management measures and their application. FAO, pp. 231.
- FAO (2012) The state of world fisheries and aquaculture. FAO Fisheries and Aquaculture Department, pp. 230.
- Feelings J, Bartolino V, Madsen N, Catchpole T (2012) Fishery discards: factors affecting their variability within a demersal trawl fishery. *PLoS ONE*, 7, e36409.
- Félix PM, Vinagre C, Cabral HN (2011) Life-history traits of flatfish in the Northeast Atlantic and Mediterranean Sea. *Journal of Applied Ichthyology*, 27, 100-111.
- Ferraro G (2010) Domestic implementation of international regimes in developing countries- the case of marine fisheries in China, KU Leuven, pp. 286.
- Flitner M (1998) Biodiversity: Of local commons and global commodities. In: *Privatizing Nature - Political Struggles for the Global Commons* (ed. Goldman M), pp. 144-166. Pluto Press, London.
- Floor JR, van Koppen CSA, Lindeboom HJ (2013) A review of science-policy interactions in the Dutch Wadden Sea - The cockle fishery and gas exploitation controversies. *Journal of Sea Research*, 82, 165-175.
- Florin AB, Hoglund J (2007) Absence of population structure of turbot (*Psetta maxima*) in the Baltic Sea. *Molecular Ecology*, 16, 115-126.
- Florin AB, Franzen F (2010) Spawning site fidelity in Baltic Sea turbot (*Psetta maxima*). *Fisheries Research*, 102, 207-213.
- Foll M, Gaggiotti O (2008) A genome-scan method to identify selected Loci appropriate for both dominant and codominant markers: A Bayesian perspective. *Genetics*, 180, 977-993.
- Fonselius S, Valderrama J (2003) One hundred years of hydrographic measurements in the Baltic Sea. *Journal of Sea Research*, 49, 229-241.
- Fox, O'Brien, Dickey C, Nash (2000) Patterns in the spawning of cod (*Gadus morhua* L.), sole (*Solea solea* L.) and plaice (*Pleuronectes platessa* L.) in the Irish Sea as determined by generalized additive modelling. *Fisheries Oceanography*, 9, 33-49.
- Francis RC, Hixon MA, Clarke ME, Murawski SA, Ralston S (2007) Ten commandments for ecosystem-based fisheries scientists. *Fisheries*, 32, 217-233.
- Francisco SM, Faria C, Lengkeek W, *et al.* (2011) Phylogeography of the shanny *Lipophrys pholis* (Pisces: Blenniidae) in the NE Atlantic records signs of major expansion event older than the last glaciation. *Journal of Experimental Marine Biology and Ecology*, 403, 14-20.
- Fu YX (1997) Statistical tests of neutrality of mutations against population growth, hitchhiking and background selection. *Genetics*, 147, 915-925
- Fulton EA, Smith ADM, Smith DC, van Putten IE (2011) Human behaviour: the key source of uncertainty in fisheries management. *Fish and Fisheries*, 12, 1-17.
- Funk WC, McKay JK, Hohenlohe PA, Allendorf FW (2012) Harnessing genomics for delineating conservation units. *Trends in Ecology & Evolution*, 27, 489-496.
- Funtowicz SO, Ravetz JR (1993) Science for the post-normal age. *Futures*, 25, 739-755.
- Funtowicz SO, Martinez-Alier J, Munda G, Ravetz JR (1999) Information tools for environmental policy under conditions of complexity. Office for Official Publications of the European Communities, Luxembourg.
- Gaggiotti OE, Bekkevold D, Jørgensen HBH, *et al.* (2009) Disentangling the effects of evolutionary, demographic and environmental factors influencing genetic structure of natural populations: Atlantic herring as case study. *Evolution*, 63, 2939-2951.
- Gaines SD, White C, Carr MH, Palumbi SR (2010) Designing marine reserve networks for both conservation and fisheries management. *Proceedings of the National Academy of Sciences*, 107, 18286-18293.
- Galarza JA, Carreras-Carbonell J, Macpherson E, *et al.* (2009a) The influence of oceanographic fronts and early-life-history traits on connectivity among littoral fish species. *Proceedings of the National Academy of Sciences*, 106, 1473-1478.
- Galarza JA, Turner GF, Macpherson E, Rico C (2009b) Patterns of genetic differentiation between two co-occurring demersal species: the red mullet (*Mullus barbatus*) and the striped red mullet (*Mullus surmuletus*). *Canadian Journal of Fisheries and Aquatic Sciences*, 66, 1478-1490.
- Galindo HM, Pfeiffer-Herbert AS, McManus LA, *et al.* (2010) Seascape genetics along a steep cline: using genetic patterns to test predictions of marine larval dispersal. *Molecular Ecology*, 19, 3692-3707.
- Galtier N, Nabholz B, GléMin S, Hurst GDD (2009) Mitochondrial DNA as a marker of molecular diversity: a reappraisal. *Molecular Ecology*, 18, 4541-4550.

- Garcia SM, Zerbi A, Aliaume C, Do Chi T, Lasserre G (2003) The ecosystem approach to fisheries. Issues, terminology, principles, institutional foundations, implementation and outlook. FAO, pp. 71.
- Garroway CJ, Bowman J, Wilson PJ (2011) Using a genetic network to parameterize a landscape resistance surface for fishers, Martes pennanti. *Molecular Ecology*, 20, 3978-3988.
- Gaument F, Boeuf G, Severe A, Leroux A, Mayergonstan N (1995) Effects of salinity on the ionic balance and growth of juvenile turbot. *Journal of Fish Biology*, 47, 865-876.
- Gavilanez MM, Stevens RD (2012) Role of environmental, historical and spatial processes in the structure of Neotropical primate communities: contrasting taxonomic and phylogenetic perspectives. *Global Ecology and Biogeography*, 22, 607-619.
- Gavilanez MM, Stevens RD (2013) Role of environmental, historical and spatial processes in the structure of Neotropical primate communities: contrasting taxonomic and phylogenetic perspectives. *Global Ecology and Biogeography*, 22, 607-619.
- Gell FR, Roberts CM (2003) Benefits beyond boundaries: the fishery effects of marine reserves. *Trends in Ecology and Evolution*, 18, 448-455.
- Gelman A, Rubin DB (1992) Inference from iterative simulation using multiple sequences. *Statistical Science*, 7, 457-472.
- Gibbons M, Limoges C, Nowotny H, *et al.* (1994) The new production of knowledge: the dynamics of science and research in contemporary societies. Sage, London, UK.
- Gibson RN (1997) Behaviour and the distribution of flatfishes. *Journal of Sea Research*, 37, 241-256.
- Gibson RN (2005) Flatfishes: biology and exploitation, pp. 416. Blackwell Science Ltd, Oxford.
- Gilbert B, Bennett JR (2010) Partitioning variation in ecological communities: do the numbers add up? *Journal of Applied Ecology*, 47, 1071-1082.
- Gillanders BM, Able KW, Brown JA, Eggleston DB, Sheridan PF (2003) Evidence of connectivity between juvenile and adult habitats for mobile marine fauna: an important component of nurseries. *Marine Ecology Progress Series*, 247, 281-295.
- Giragosov VE, Khanaychenko AN, Kirin MP, Gutsal DK (2012) Record of *Scophthalmus rhombus* (Pleuronectiformes: Scophthalmidae) near the Crimea. *Journal of Ichthyology*, 52, 135-140.
- Gislason H, Daan N, Rice JC, Pope JG (2010) Size, growth, temperature and the natural mortality of marine fish. *Fish and Fisheries*, 11, 149-158.
- Gjerde KM (2006) High seas fisheries management under the convention on the law of the sea. 'Oxford University Press'.
- Glez-Peña D, Gómez-Blanco D, Reboiro-Jato M, Fdez-Riverola F, Posada D (2010) ALTER: program-oriented conversion of DNA and protein alignments. *Nucleic Acids Research*, 38, 14-18.
- Goudet J (1995) FSTAT (Version 1.2): A computer program to calculate F-statistics. *Journal of Heredity*, 86, 485-486.
- Grafton RQ, Hilborn R, Ridgeway L, *et al.* (2008) Positioning fisheries in a changing world. *Marine Policy*, 32, 630-634.
- Grant W, Bowen B (1998) Shallow population histories in deep evolutionary lineages of marine fishes: insights from sardines and anchovies and lessons for conservation. *Journal of Heredity*, 89, 415-426.
- Grisel RA (2012) Gaming the system: Bio-economics, game theory & fisheries management. In: *The Selected Works of Richard A Grisel*, pp. 24.
- Groth C, Lardelli M (2002) The structure and function of vertebrate Fibroblast Growth Factor Receptor 1. *International Journal of Developmental Biology*, 46, 393-400.
- Guo SW, Thompson EA (1992) Performing the exact test of hardy-weinberg proportion for multiple alleles. *Biometrics*, 48, 361-372.
- Gutierrez NL, Hilborn R, Defeo O (2011) Leadership, social capital and incentives promote successful fisheries. *Nature*, 470, 386-389.
- Hachero-Cruzado I, García-López Á, Herrera M, *et al.* (2007) Reproductive performance and seasonal plasma sex steroid and metabolite levels in a captive wild broodstock of brill *Scophthalmus rhombus* L. *Aquaculture Research*, 38, 1161-1174.
- Halpern BS, Warner RR (2002) Marine reserves have rapid and lasting effects. *Ecology Letters*, 5, 361-366.
- Halpern BS, Walbridge S, Selkoe KA, *et al.* (2008) A global map of human impact on marine ecosystems. *Science*, 319, 948-952.
- Hanna S (2003) Transition in the American fishing commons: Management problems and institutional design challenges. In: *The Commons in the new Millennium* (eds. Dolšák N, Ostrom E), pp. 67-76. The MIT Press, Cambridge (MA) and London.
- Hansen MM, Olivieri ISAB, Waller DM, Nielsen ERE, Group TGW (2012) Monitoring adaptive genetic responses to environmental change. *Molecular Ecology*, 21, 1311-1329.

- Hardin G (1968) The tragedy of the commons. *Science*, 162, 1243-1248.
- Hare MP, Nunney L, Schwartz MK, *et al.* (2011) Understanding and estimating effective population size for practical application in marine species management. *Conservation Biology*, 25, 438-449.
- Hauser L, Carvalho GR (2008) Paradigm shifts in marine fisheries genetics: ugly hypotheses slain by beautiful facts. *Fish and Fisheries*, 9, 333-362.
- Hauser L, Seeb JE (2008) Advances in molecular technology and their impact on fisheries genetics. *Fish and Fisheries*, 9, 473-486.
- Hedgecock D, Pudovkin AI (2011) Sweepstakes reproductive success in highly fecund marine fish and shellfish: A review and commentary. *Bulletin of Marine Science*, 87, 971-1002.
- Heino M, Dieckmann U (2009) Fisheries-induced evolution. In: eLS. John Wiley & Sons, Ltd.
- Heino M, Baulier Lc, Boukal DS, *et al.* (2013) Can fisheries-induced evolution shift reference points for fisheries management? *ICES Journal of Marine Science: Journal du Conseil*, 70, 707-721.
- Hellberg ME, Burton RS, Neigel JE, Palumbi SR (2002) Genetic assessment of connectivity among marine populations. *Bulletin of Marine Science*, 70, 273-290.
- Hellberg ME (2009) Gene flow and isolation among populations of marine animals. *Annual Review of Ecology, Evolution, and Systematics*, 40, 291-310.
- Hemmer-Hansen J, Nielsen EE, Frydenberg J, Loeschcke V (2007a) Adaptive divergence in a high gene flow environment: Hsc70 variation in the European flounder (*Platichthys flesus* L.). *Heredity*, 99, 592-600.
- Hemmer-Hansen J, Nielsen EE, Gronkjaer P, Loeschcke V (2007b) Evolutionary mechanisms shaping the genetic population structure of marine fishes; lessons from the European flounder (*Platichthys flesus* L.). *Molecular Ecology*, 16, 3104-3118.
- Hendry AP, Farrugia TJ, Kinnison MT (2008) Human influences on rates of phenotypic change in wild animal populations. *Molecular Ecology*, 17, 20-29.
- Héritier A (2001) Differential Europe: The European union impact on national policymaking. In: *Differential Europe - The European Union Impact on National Policymaking* (ed. Héritier A, Kerwer D, Knill C, Lehmkuhl D, Teutsch M, Douillet A.C.), pp. 342. Rowman & Littlefield Publishers, Inc., Lanham - Boulder - New York - Oxford.
- Hewitt G (2000) The genetic legacy of the Quaternary ice ages. *Nature*, 405, 907-913.
- Hewitt G (2004) Genetic consequences of climatic oscillations in the Quaternary. *Philosophical Transactions of the Royal Society of London Series B-Biological Sciences*, 359, 183-195.
- Heymans JJ, Mackinson S, Sumaila UR, Dyck A, Little A (2011) The impact of subsidies on the ecological sustainability and future profits from North Sea fisheries. *PLoS ONE*, 6, e20239.
- Hiddink JG, Hutton T, Jennings S, Kaiser MJ (2006) Predicting the effects of area closures and fishing effort restrictions on the production, biomass, and species richness of benthic invertebrate communities. *ICES Journal of Marine Science: Journal du Conseil*, 63, 822-830.
- Hilborn R, Walters CJ (1992) *Quantitative fisheries stock assessment: Choice, dynamics and uncertainty*. Chapman and Hall, New York.
- Hilborn R, Branch TA, Ernst B, *et al.* (2003a) State of the world's fisheries. *Annual Review of Environment and Resources*, 28, 359-399.
- Hilborn R, Quinn TP, Schindler DE, Rogers DE (2003b) Biocomplexity and fisheries sustainability. *Proceedings of the National Academy of Sciences*, 100, 6564-6568.
- Hilborn R, Stokes K, Maguire J-J, *et al.* (2004) When can marine reserves improve fisheries management? *Ocean & Coastal Management*, 47, 197-205.
- Hilborn R (2007) Defining success in fisheries and conflicts in objectives. *Marine Policy*, 31, 153-158.
- Hilborn R (2011) Future directions in ecosystem based fisheries management: A personal perspective. *Fisheries Research*, 108, 235-239.
- Hill M, Hupe P (2002) *Implementing Public Policy*. SAGE Publications Ltd, London.
- Ho SYW, Phillips MJ, Cooper A, Drummond AJ (2005) Time dependency of molecular rate estimates and systematic overestimation of recent divergence times. *Molecular Biology and Evolution*, 22, 1561-1568.
- Hoarau G, Holla S, Lescasse R, Stam WT, Olsen JL (2002) Heteroplasmy and evidence for recombination in the mitochondrial control region of the flatfish *Platichthys flesus*. *Molecular Biology and Evolution*, 19, 2261-2264.
- Hoarau G, Boon E, Jongma DN, *et al.* (2005) Low effective population size and evidence for inbreeding in an overexploited flatfish, plaice (*Pleuronectes platessa* L.). *Proceedings of the Royal Society B-Biological Sciences*, 272, 497-503.
- Holm PN, K.N. (2004) The TAC machine, appendix B, Working document, pp. 40-51.
- Holmes J, Lock J (2010) Generating the evidence for marine fisheries policy and management. *Marine Policy*, 34, 29-35.

- Hoppe R (1999) Policy analysis, science and politics: from 'speaking truth to power' to 'making sense together'. *Science and Public Policy*, 26, 201-210.
- Howlett M, Ramesh M (1998) Policy subsystem configurations and policy change: Operationalizing the postpositivist analysis of the politics of the policy process. *Policy Studies Journal*, 26, 466-481.
- Howlett M, Eliadis P, Hill M (2005) *Designing government: from instruments to governance*. McGill-Queen's University Press.
- Howlett M, Ramesh M, Perl A (2009) *Studying public policy: Policy cycles & public subsystems*. Oxford University Press.
- Hubisz MJ, Falush D, Stephens M, Pritchard JK (2009) Inferring weak population structure with the assistance of sample group information. *Molecular Ecology Resources*, 9, 1322-1332.
- Hudson ME (2008) Sequencing breakthroughs for genomic ecology and evolutionary biology. *Molecular Ecology Resources*, 8, 3-17.
- Huelsenbeck JP, Ronquist F (2001) MRBAYES: Bayesian inference of phylogenetic trees. *Bioinformatics*, 17, 754-755.
- Hufnagel M, Peck MA, Nash RDM, Pohlmann T, Rijnsdorp AD (2012) Changes in potential North Sea spawning grounds of plaice (*Pleuronectes platessa* L.) based on early life stage connectivity to nursery habitats. *Journal of Sea Research*, 1-14.
- Hughes JB, Daily GC, Ehrlich PR (1997) Population Diversity: Its Extent and Extinction. *Science*, 278, 689-692.
- Hunter E, Metcalfe JD, Reynolds JD (2003) Migration route and spawning area fidelity by North Sea plaice. *Proceedings of the Royal Society of London. Series B: Biological Sciences*, 270, 2097-2103.
- Hunter E, Metcalfe JD, Arnold GP, Reynolds JD (2004) Impacts of migratory behaviour on population structure in North Sea plaice. *Journal of Animal Ecology*, 73, 377-385.
- Huret M, Sourisseau M, Petitgas P, et al. (2013) A multi-decadal hindcast of a physical-biogeochemical model and derived oceanographic indices in the Bay of Biscay. *Journal of Marine Systems*, 109-110, Supplement, S77-S94.
- Hurley IA, Mueller RL, Dunn KA, et al. (2007) A new time-scale for ray-finned fish evolution. *Proceedings of the Royal Society B: Biological Sciences*, 274, 489-498.
- Hutchings JA, Reynolds JD (2004) Marine fish population collapses: Consequences for recovery and extinction risk. *Bioscience*, 54, 13.
- Hutchinson WF, Carvalho GR, Rogers SI (2001) Marked genetic structuring in localized spawning populations of cod *Gadus morhua* in the North Sea and adjoining waters, as revealed by microsatellites. *Marine Ecology Progress Series*, 223, 251-260.
- Hutchinson WF, Oosterhout Cv, Rogers SI, Carvalho GR (2003) Temporal analysis of archived samples indicates marked genetic changes in declining North Sea cod (*Gadus morhua*). *Proceedings of the Royal Society of London. Series B: Biological Sciences*, 270, 2125-2132.
- ICES (2008) Report of the Working Group on Fishery Systems (WGFS). pp. 49.
- ICES (2010) Report of the Working Group on Assessment of New MoU Species (WGNEW). ICES, pp. 603.
- ICES (2011a) Report of the Data Deficiency Coordination Meeting with the RACs (WKDDRAC). pp. 17.
- ICES (2011b) Report on the Second Data Deficiency Coordination Meeting with the RACs (WKDDRAC2). ICES, pp. 47.
- ICES (2012a) ICES implementation of advice for data-limited stocks in 2012 in its 2012 advice. pp. 42.
- ICES (2012b) Report of the Inter-Benchmark Protocol on new species (turbot and sea bass; IBPNew 2012). ICES, pp. 239.
- ICES (2012c) Report of the Working Group on Assessment of New MoU species (WGNEW). ICES CM/ACOM:20, pp. 258.
- ICES (2012d) Report of the workshop to finalize the ICES data-limited stocks (DLS) methodologies documentation in an operational form for the 2013 advice season and to make recommendations on target categories for data-limited stocks (WKLIFE II). pp. 46.
- ICES (2012e) Report of the working Group on the application of genetics in fisheries and mariculture (WGAGFM). ICES, pp. 61.
- ICES (2013) Report of the study group on practical implementation of discard sampling plans (SGPIDS). ICES CM 2013/ACOM:56, pp. 143.
- Imslund AK, Sunde LM, Folkvord A, Stefansson SO (1996) The interaction of temperature and fish size on growth of juvenile turbot. *Journal of Fish Biology*, 49, 926-940.
- Imslund AK, Foss A, Naevdal G, Stefansson SO (2001a) Selection or adaptation: Differences in growth performance of juvenile turbot (*Scophthalmus maximus* Rafinesque) from two close-by localities off Norway. *Sarsia*, 86, 43-51.
- Imslund AK, Foss A, Stefansson SO (2001b) Variation in food intake, food conversion efficiency and growth of juvenile turbot from different geographic strains. *Journal of Fish Biology*, 59, 449-454.

- Imsland AK, Scanu G, Naevald G (2003) New variants of the haemoglobins of turbot (*Scophthalmus maximus*): possible use in population genetics studies and aquaculture. *Sarsia*, 88, 55-64.
- Ivanova NV, Zemplak TS, Hanner RH, Hebert PDN (2007) Universal primer cocktails for fish DNA barcoding. *Molecular Ecology Notes*, 7, 544-548.
- Iyengar A, Piyapattanakorn S, Heipel DA, *et al.* (2000) A suite of highly polymorphic microsatellite markers in turbot (*Scophthalmus maximus* L.) with potential for use across several flatfish species. *Molecular Ecology*, 9, 368-371.
- Jager Z (1999) Selective tidal stream transport of flounder larvae (*Platichthys flesus* L.) in the Dollard (Ems Estuary). *Estuarine, Coastal and Shelf Science*, 49, 347-362.
- Jakobsdóttir KB, Pardoe H, Magnússon Á, *et al.* (2011) Historical changes in genotypic frequencies at the Pantophysin locus in Atlantic cod (*Gadus morhua*) in Icelandic waters: evidence of fisheries-induced selection? *Evolutionary Applications*, 4, 562-573.
- Jennings S, Kaiser MJ (1998) The effects of fishing on marine ecosystems. In: *Advances in Marine Biology* (eds. J.H.S. Blaxter AJS, P.A. Tyler), pp. 201-352. Academic Press.
- Jennings S, Rice J (2011) Towards an ecosystem approach to fisheries in Europe: a perspective on existing progress and future directions. *Fish and Fisheries*, 12, 125-137.
- Jentoft S, Chuenpagdee R (2009) Fisheries and coastal governance as a wicked problem. *Marine Policy*, 33, 553-560.
- Johannesson K, André C (2006) Life on the margin: genetic isolation and diversity loss in a peripheral marine ecosystem, the Baltic Sea. *Molecular Ecology*, 15, 2013-2029.
- Johannesson K, Smolarz K, Grahn M, André C (2011) The future of Baltic Sea populations: Local extinction or evolutionary rescue? *Ambio*, 40, 179-190.
- Johns GC, Avise JC (1998) A comparative summary of genetic distances in the vertebrates from the mitochondrial cytochrome b gene. *Molecular Biology and Evolution*, 15, 1481-1490.
- Johnston IA, Bower NI, Macqueen DJ (2011) Growth and the regulation of myotomal muscle mass in teleost fish. *Journal of Experimental Biology*, 214, 1617-1628.
- Jombart T, Pontier D, Dufour AB (2009) Genetic markers in the playground of multivariate analysis. *Heredity*, 102, 330-341.
- Jombart T, Devillard S, Balloux F (2010) Discriminant analysis of principal components: a new method for the analysis of genetically structured populations. *BMC Genetics*, 11, 1-15.
- Jones A (1970) Some aspects of the biology of the turbot (*Scophthalmus maximus* L.) with special reference to feeding and growth in the juvenile stage, University of East Anglia.
- Jones A (1972) Studies on egg development and larval rearing of turbot (*Scophthalmus maximus* L.) and brill (*Scophthalmus rhombus* L.) in laboratory. *Journal of the Marine Biological Association of the United Kingdom*, 52, 965-986.
- Jones A (1974) Sexual maturity, fecundity and growth of the turbot *Scophthalmus maximus* L. *J.Mar.Biol.Assoc.U.K.*, 54, 109-125.
- Jones AG, Small CM, Paczolt KA, Ratterman NL (2010) A practical guide to methods of parentage analysis. *Molecular Ecology Resources*, 10, 6-30.
- Jones GP, Planes S, Thorrold SR (2005) Coral reef fish larvae settle close to home. *Current Biology*, 15, 1314-1318.
- Joost S, Bonin A, Bruford MW, *et al.* (2007) A spatial analysis method (SAM) to detect candidate loci for selection: towards a landscape genomics approach to adaptation. *Molecular Ecology*, 16, 3955-3969.
- Jorde PE, Ryman N (1995) Temporal allele frequency change and estimation of effective size in populations with overlapping generations. *Genetics*, 139, 1077-1090.
- Jørgensen C, Enberg K, Dunlop ES, *et al.* (2007) Ecology: Managing evolving fish stocks. *Science*, 318, 1247-1248.
- Jørgensen BH, Hansen MM, Bekkevold D, Ruzzante DE, Loeschcke V (2005) Marine landscapes and population genetic structure of herring (*Clupea harengus* L.) in the Baltic Sea. *Molecular Ecology*, 14, 3219-3234.
- Joyner CC (1998) *Governing the frozen commons - The antarctic regime and environmental protection*. University of South Carolina Press.
- Kales S, Parks-Dely J, Schulte P, Dixon B (2006) Beta-2-microglobulin gene expression is maintained in rainbow trout and Atlantic salmon kept at low temperatures. *Fish & Shellfish Immunology*, 21, 241-247.
- Karas P, Klingsheim V (1997) Effects of temperature and salinity on embryonic development of turbot (*Scophthalmus maximus* L.) from the North Sea, and comparisons with Baltic populations. *Helgolander Meeresuntersuchungen*, 51, 241-247.
- Kelly CJ, Codling EA (2006) Cheap and dirty fisheries science and management in the North Atlantic. *Fisheries Research*, 79, 233-238.
- Kenchington E (2003) The effects of fishing on species and genetic diversity. In: *Responsible fisheries in the marine ecosystem* (eds. Sinclair M, Valdimarson G), pp. 235-253. CAB international, Wallingford, Oxon, UK.

- Kenchington E, Heino M, Nielsen EE (2003) Managing marine genetic diversity: time for action? ICES Journal of Marine Science: Journal du Conseil, 60, 1172-1176.
- Kenny AJ, Skjoldal HR, Engelhard GH, Kershaw PJ, Reid JB (2009) An integrated approach for assessing the relative significance of human pressures and environmental forcing on the status of Large Marine Ecosystems. Progress in Oceanography, 81, 132-148.
- Kerby TK, Cheung WWL, van Oosterhout C, Engelhard GH (2013) Entering uncharted waters: Long-term dynamics of two data limited fish species, turbot and brill, in the North Sea. Journal of Sea Research, 84, 87-95.
- Kettle AJ, Morales-Muniz A, Rosello-Izquierdo E, Heinrich D, Vollestad LA (2011) Refugia of marine fish in the northeast Atlantic during the last glacial maximum: concordant assessment from archaeozoology and palaeotemperature reconstructions. Climate of the Past, 7, 181-201.
- Knutsen H, Jorde PE, André C, Stenseth NC (2003) Fine-scaled geographical population structuring in a highly mobile marine species: the Atlantic cod. Molecular Ecology, 12, 385-394.
- Knutsen H, Olsen EM, Jorde PE, *et al.* (2011) Are low but statistically significant levels of genetic differentiation in marine fishes 'biologically meaningful'? A case study of coastal Atlantic cod. Molecular Ecology, 20, 768-783.
- Kocher TD, Stepien CA (1997) Molecular systematics of fishes Academic Press, San Diego, California.
- Koressaar T, Remm M (2007) Enhancements and modifications of primer design program Primer3. Bioinformatics, 23, 1289-1291.
- Köster WF, Schnack D, Möllmann C (2003) Scientific knowledge of biological processes potentially useful in fish stock predictions. Scientia Marina, 67, 30.
- Kraak SBM, Buisman FC, Dickey-Collas M, *et al.* (2008) The effect of management choices on the sustainability and economic performance of a mixed fishery: a simulation study. ICES Journal of Marine Science: Journal du Conseil, 65, 697-712.
- Kraak SBM, Kelly CJ, Codling EA, Rogan E (2010) On scientists' discomfort in fisheries advisory science: the example of simulation-based fisheries management-strategy evaluations. Fish and Fisheries, 11, 119-132.
- Kraak SBM (2011) Exploring the 'public goods game' model to overcome the tragedy of the commons in fisheries management. Fish and Fisheries, 12, 18-33.
- Kraak SBM, Reid DG, Gerritsen HD, *et al.* (2012) 21st century fisheries management: a spatio-temporally explicit tariff-based approach combining multiple drivers and incentivizing responsible fishing. ICES Journal of Marine Science: Journal du Conseil.
- Kraak SBM, Bailey N, Cardinale M, *et al.* (2013) Lessons for fisheries management from the EU cod recovery plan. Marine Policy, 37, 200-213.
- Krichner A (2003) International marine environmental law - institutions, implementation and innovations. Kluwer Law International, The Hague-New York-London.
- Kristensen TN, Pedersen KS, Vermeulen CJ, Loeschke V (2010) Research on inbreeding in the omic era. Trends in ecology & evolution (Personal edition), 25, 44-52.
- Kuparinen A, Merilä J (2007) Detecting and managing fisheries-induced evolution. Trends in Ecology & Evolution, 22, 652-659.
- La Viña AGM, Gretchen H, and De Rose A.M. (2003) The outcomes of Johannesburg: Assessing the world summit on sustainable development. pp. 14.
- Lacroix G, Maes GE, Bolle LJ, Volckaert FAM (2012) Modelling dispersal dynamics of the early life stages of a marine flatfish (*Solea solea* L.). Journal of Sea Research, 13-25.
- Lage C, Kornfield I (2006) Reduced genetic diversity and effective population size in an endangered Atlantic salmon (*Salmo Salar*) population from Maine, USA. Conservation Genetics, 7, 91-104.
- Lambeck K, Purcell A (2005) Sea-level change in the Mediterranean Sea since the LGM: model predictions for tectonically stable areas. Quaternary Science Reviews, 24, 1969-1988.
- Lambeck R. J. 1997. Focal Species: A Multi-Species Umbrella for Nature Conservation. Conservation Biology 11, 849-856.
- Lamichhaney S, Barrio AM, Rafati N, *et al.* (2012) Population-scale sequencing reveals genetic differentiation due to local adaptation in Atlantic herring. Proceedings of the National Academy of Sciences, 109, 19345-19350.
- Lang D, Wiek A, Bergmann M, *et al.* (2012) Transdisciplinary research in sustainability science: practice, principles, and challenges. Sustainability Science, 7, 25-43.
- Larmuseau MHD, Raeymaekers JAM, Ruddick KG, Van Houdt JKJ, Volckaert FAM (2009) To see in different seas: spatial variation in the rhodopsin gene of the sand goby (*Pomatoschistus minutus*). Molecular Ecology, 18, 4227-4239.
- Larmuseau MHD, Vancampenhout KIM, Raeymaekers JAM, Van Houdt JKJ, Volckaert FAM (2010) Differential modes of selection on the rhodopsin gene in coastal Baltic and North Sea populations of the sand goby (*Pomatoschistus minutus*). Molecular Ecology, 19, 2256-2268.

- Larsson LC, Laikre L, Andre C, Dahlgren TG, Ryman N (2009) Temporally stable genetic structure of heavily exploited Atlantic herring (*Clupea harengus*) in Swedish waters. *Heredity*, 104, 40-51.
- Larsen PF, Nielsen EE, Williams TD, *et al.* (2007) Adaptive differences in gene expression in European flounder (*Platichthys flesus*). *Molecular Ecology*, 16, 4674-4683.
- Larsen PF, Nielsen EE, Meier K, *et al.* (2012) Differences in salinity tolerance and gene expression between two populations of Atlantic Cod (*Gadus morhua*) in response to salinity stress. *Biochemical Genetics*, 50, 454-466.
- Lasky JR, Des Marais DL, McKay JK, *et al.* (2012) Characterizing genomic variation of *Arabidopsis thaliana*: the roles of geography and climate. *Molecular Ecology*, 21, 5512-5529.
- Laugen AT, Engelhard GH, Whitlock R, *et al.* (2014) Evolutionary impact assessment: accounting for evolutionary consequences of fishing in an ecosystem approach to fisheries management. *Fish and Fisheries*, 15,65-96.
- Legendre P, Legendre L (2012) *Numerical ecology*, 3rd edn. Elsevier, Quebec.
- Lemey P, Salemi M, Vandamme A-M (2009) *The Phylogenetic Handbook*, 2nd edition. Cambridge University Press, Cambridge, UK.
- Lescrauwaet A-K (2013) Belgian fisheries: ten decades, seven seas, forty species: Historical time-series to reconstruct landings, catches, fleet and fishing areas from 1900, Ghent University (UGent), pp. 271.
- Librado P, Rozas J (2009) DnaSP v5: a software for comprehensive analysis of DNA polymorphism data. *Bioinformatics*, 25, 1451-1452.
- Limborg MT, Helyar SJ, de Bruyn M, *et al.* (2012) Environmental selection on transcriptome-derived SNPs in a high gene flow marine fish, the Atlantic herring (*Clupea harengus*). *Molecular Ecology*, 21, 3686-3703.
- Liu D-W, Tsai S-M, Lin B-F, Jiang Y-J, Wang W-P (2013) Fibroblast growth factor receptor 2c signaling is required for intestinal cell differentiation in Zebrafish. *PLoS ONE*, 8, e58310.
- Lo Brutto S, Arculeo M, Stewart Grant W (2011) Climate change and population genetic structure of marine species. *Chemistry and Ecology*, 27, 107-119.
- Lowe WH, Allendorf FW (2010) What can genetics tell us about population connectivity? *Molecular Ecology*, 19, 5320-5320.
- Luikart G, England PR, Tallmon D, Jordan S, Taberlet P (2003) The power and promise of population genomics: from genotyping to genome typing. *Nat Rev Genet*, 4, 981-994.
- Lundy CJ, Rico C, Hewitt GM (2000) Temporal and spatial genetic variation in spawning grounds of European hake (*Merluccius merluccius*) in the Bay of Biscay. *Molecular Ecology*, 9, 2067-2079.
- Mac Aoidh E, Martinsohn JT, Maes GE, Cariani A, Nielsen EE (2013) Exploring geovisualization symbology for landscape genetics. *Transactions in GIS*, 17, 267-281.
- Mace P (1997) *Developing and sustaining world fisheries resources: the state of science and management*, pp. 1-20.
- Mackinson S, Wilson DC, Galiay P, Deas B (2011) Engaging stakeholders in fisheries and marine research. *Marine Policy*, 35, 18-24.
- Maes F (2008) The international legal framework for marine spatial planning. *Marine Policy*, 32, 797-810.
- Maggs CA, Castilho R, Foltz D, *et al.* (2008) Evaluating signatures of glacial refugia for North Atlantic benthic marine taxa. *Ecology*, 89, S108-S122.
- Mäkinen HS, Cano JM, Merilä J (2008) Identifying footprints of directional and balancing selection in marine and freshwater three-spined stickleback (*Gasterosteus aculeatus*) populations. *Molecular Ecology*, 17, 3565-3582.
- Manel S, Joost S, Epperson BK, *et al.* (2010) Perspectives on the use of landscape genetics to detect genetic adaptive variation in the field. *Molecular Ecology*, 19, 3760-3772.
- Manel S, Poncet BN, Legendre P, Gugerli F, Holderegger R (2010) Common factors drive adaptive genetic variation at different spatial scales in *Arabidopsis thaliana*. *Molecular Ecology*, 19, 3824-3835.
- Martinsohn JT, Ogden R (2008) A forensic genetic approach to European fisheries enforcement. *Forensic Science International: Genetics Supplement Series*, 1, 610-611.
- Martinsohn JT (2011) Detering illegal activities in the fisheries sector. European Commission-Joint Research Centre, pp. 72.
- Maslow AH (1943) A theory of human motivation. *Psychological Review*, 50, 370-396.
- Matschiner M, Salzburger W (2009) TANDEM: integrating automated allele binning into genetics and genomics workflows. *Bioinformatics*, 25, 1982-1983.
- May PJ (2003) Policy design and implementation. In: *Handbook of Public Administration* (eds. Peters BG, Pierre J), pp. 223-233. SAGE Publications, London- Thousand Oaks - Delhi.
- McCairns RJS, Bernatchez L (2008) Landscape genetic analyses reveal cryptic population structure and putative selection gradients in a large-scale estuarine environment. *Molecular Ecology*, 17, 3901-3916.
- McEvoy LA (1984) Ovulatory rhythms and over-ripening of eggs in cultivated turbot (*Scophthalmus maximus* L.). *Journal of Fish Biology*, 24, 437-488.

- McGlauffin MT, Schindler DE, Seeb LW, *et al.* (2011) Spawning habitat and geography influence population structure and juvenile migration timing of Sockeye salmon in the Wood River Lakes, Alaska. *Transactions of the American Fisheries Society*, 140, 763-782.
- McNie EC (2007) Reconciling the supply of scientific information with user demands: an analysis of the problem and review of the literature. *Environmental Science & Policy*, 10, 17-38.
- Megrey BA, Link JS, Moksness E (2009) Comparative marine ecosystem structure and function: Descriptors and characteristics preface. *Progress in Oceanography*, 81, 1.
- Metcalf JD, Hunter E, Buckley AA (2006) The migratory behaviour of North Sea plaice: Currents, clocks and clues. *Marine and Freshwater Behaviour and Physiology*, 39, -25-36.
- Meynard CN, Mouillot D, Mouquet N, Douzery EJP (2012) A phylogenetic perspective on the evolution of mediterranean teleost fishes. *PLoS ONE*, 7, e36443.
- Michaels S (2009) Matching knowledge brokering strategies to environmental policy problems and settings. *Environmental Science & Policy*, 12, 994-1011.
- Mickwitz P (2003) A Framework for Evaluating Environmental Policy Instruments: Context and Key Concepts. *Evaluation*, 9, 415-436.
- Milano I, Babbucci M, Panitz F, *et al.* (2011) Novel tools for conservation genomics: Comparing two high-throughput approaches for SNP discovery in the transcriptome of the European hake. *PLoS ONE*, 6, e28008.
- Millán A, Gómez-Tato A, Fernández C, *et al.* (2010) Design and performance of a turbot (*Scophthalmus maximus*) oligo-microarray based on ESTs from immune tissues. *Marine Biotechnology*, 12, 13.
- Miller KM, Li S, Kaukinen KH, *et al.* (2011) Genomic signatures predict migration and spawning failure in wild Canadian salmon. *Science*, 331, 214-217.
- Miya M, Takeshima H, Endo H, *et al.* (2003) Major patterns of higher teleostean phylogenies: a new perspective based on 100 complete mitochondrial DNA sequences. *Molecular Phylogenetics and Evolution*, 26, 121-138.
- Molecular Ecology Resources Primer Development C, A'Hara SW, Amouroux P, *et al.* (2012) Permanent genetic resources added to molecular ecology resources database 1 August 2011-30 September 2011. *Molecular Ecology Resources*, 12, 185-189.
- Mollet F, Kraak S, Rijnsdorp A (2007) Fisheries-induced evolutionary changes in maturation reaction norms in North Sea sole (*Solea solea*). *Marine Ecology Progress Series*, 351, 189-199.
- Mollet FM (2010) Evolutionary effects of fishing and implications for sustainable management: a case study of North Sea plaice and sole, Wageningen University, pp. 202.
- Mollet FM, Engelhard GH, Vainikka A, *et al.* (2012) Spatial variation in growth, maturation schedules and reproductive investment of female sole (*Solea solea*) in the Northeast Atlantic. *Journal of Sea Research*, 109-121.
- Moritz C (1994) Application of mitochondrial DNA analysis in conservation-a critical review. *Molecular Ecology*, 3, 401-411.
- Moritz C, Potter S (2013) The importance of an evolutionary perspective in conservation policy planning. *Molecular Ecology*, 22, 5969-5971.
- Mosquera I, Côté IM, Jennings S, Reynolds JD (2000) Conservation benefits of marine reserves for fish populations. *Animal Conservation*, 3, 321-332.
- Mudie PJ, Rochon A, Aksu AE (2002) Pollen stratigraphy of Late Quaternary cores from Marmara Sea: land-sea correlation and paleoclimatic history. *Marine Geology*, 190, 203-231.
- Murawski SA, Brown R, Lai HL, Rago PJ, Hendrickson L (2010) Large-scale closed areas as a fishery-management tool in temperate marine systems: the Georges Bank experience. *Bulletin of Marine Science*, 66, 775-798.
- Myers RA, Worm B (2003) Rapid worldwide depletion of predatory fish communities. *Nature*, 423, 280-283.
- Narum SR, Buerkle CA, Davey JW, Miller MR, Hohenlohe PA (2013) Genotyping-by-sequencing in ecological and conservation genomics. *Molecular Ecology*, 22, 2841-2847.
- Nelson MP, Vucetich JA (2009) On advocacy by environmental scientists: What, whether, why and how. *Conservation Biology*, 23, 12.
- Nicholson E, Lindenmayer DB, Frank K, Possingham HP (2013) Testing the focal species approach to making conservation decisions for species persistence. *Diversity and Distributions*, 19, 530-540.
- Nielsen EE, Nielsen PH, Meldrup D, Hansen MM (2004) Genetic population structure of turbot (*Scophthalmus maximus* L.) supports the presence of multiple hybrid zones for marine fishes in the transition zone between the Baltic Sea and the North Sea. *Molecular Ecology*, 13, 585-595.
- Nielsen EE, Hansen MM, Ruzzante DE, Meldrup D, Gronkjaer P (2003) Evidence of a hybrid-zone in Atlantic cod (*Gadus morhua*) in the Baltic and the Danish Belt Sea revealed by individual admixture analysis. *Molecular Ecology*, 12, 1497-1508.



- Nielsen EE, Hansen MM, Meldrup D (2006) Evidence of microsatellite hitch-hiking selection in Atlantic cod (*Gadus morhua*): implications for inferring population structure in non-model organisms. *Molecular Ecology*, 15, 3219-3229.
- Nielsen E, Hemmer-Hansen J, Poulsen N, *et al.* (2009a) Genomic signatures of local directional selection in a high gene flow marine organism; the Atlantic cod (*Gadus morhua*). *BMC Evolutionary Biology*, 9, 1-11.
- Nielsen EE, Hemmer-Hansen J, Larsen P, Bekkevold D (2009b) Population genomics of marine fishes: identifying adaptive variation in space and time. *Molecular Ecology*, 18, 3128-3150.
- Nielsen E, Wright P, Hemmer-Hansen J, *et al.* (2009c) Microgeographical population structure of cod *Gadus morhua* in the North Sea and west of Scotland: the role of sampling loci and individuals. *Marine Ecology Progress Series*, 376, 213-225.
- Nielsen EE, Cariani A, Aoidh EM, *et al.* (2012) Gene-associated markers provide tools for tackling illegal fishing and false eco-certification. *Nat Commun*, 3, 851.
- Nielsen JG (1986) Scophthalmidae. In: *Fishes of the North-eastern Atlantic and the Mediterranean* (ed. P.J.P.Whitehead M-LB, J.-C.Hureau, J.Nielsen and E.Tortonese), pp. 1287-1293. United Nations Educational, Scientific and Cultural Organizations.
- Nissling A, Westin L, Hjerne O (2002) Reproductive success in relation to salinity for three flatfish species, dab (*Limanda limanda*), plaice (*Pleuronectes platessa*), and flounder (*Pleuronectes flesus*), in the brackish water Baltic Sea. *ICES Journal of Marine Science: Journal du Conseil*, 59, 93-108.
- Nissling A, Johansson U, Jacobsson M (2006) Effects of salinity and temperature conditions on the reproductive success of turbot (*Scophthalmus maximus*) in the Baltic Sea. *Fisheries Research*, 80, 230-238.
- Nissling A, Florin A-B, Thorsen A, Bergström U (2013) Egg production of turbot, *Scophthalmus maximus*, in the Baltic Sea. *Journal of Sea Research*, 84, 77-86.
- Nolf D (2013) The diversity of fish otoliths, past and present. Royal Belgian Institute of Natural Sciences, Brussels.
- Nosil P, Funk DJ, Ortiz-Barrientos D (2009) Divergent selection and heterogeneous genomic divergence. *Molecular Ecology*, 18, 375-402.
- Ogden R (2008) Fisheries forensics: the use of DNA tools for improving compliance, traceability and enforcement in the fishing industry. *Fish and Fisheries*, 9, 462-472.
- Oksanen J (2011) Multivariate Analysis of Ecological Communities in R: vegan tutorial. <http://cc.oulu.fi/~jarioksa/opetus/metodi/vegantutor.pdf>.
- Ongena E, Delbare D, De Clerck R (1998) Collection and modelling of biological data for turbot stock assessment in support of the Common Fisheries Policy. Project financed by the EC - DG XIV 95/039.
- Orsini L, Mergeay J, Vanoverbeke J, De Meester L (2012) The role of selection in driving landscape genomic structure of the waterflea (*Daphnia magna*). *Molecular Ecology*, 583-601.
- OSPAR Commission (2000) Quality Status Report 2000. OSPAR Commission, pp. 108 + vli.
- Österblom H, Sissenwine M, Symes D, *et al.* (2011) Incentives, social-ecological feedbacks and European fisheries. *Marine Policy*, 35, 568-574.
- Ostrom E, Gardner R, Walker J (1994) Rules, games & common-pool resources, pp. 392. The University of Michigan Press.
- Ostrom E (2009) A general framework for analyzing sustainability of social-ecological systems. *Science*, 325, 419-422.
- Otto L, Zimmerman JTF, Furnes GK, *et al.* (1990) Review of the physical oceanography of the North Sea. *Netherlands Journal of Sea Research*, 26, 161-238.
- Ouborg NJ, Pertoldi C, Loeschke V, Bijlsma R, Hedrick PW (2010) Conservation genetics in transition to conservation genomics. *Trends in Genetics*, 26, 177-187.
- Pala C (2013) Detective work uncovers under-reported overfishing. In: *Nature News*. Nature Publishing Group.
- Palsboll PJ, Bérubé M, Allendorf FW (2007) Identification of management units using population genetic data. *Trends in ecology & evolution* (Personal edition), 22, 11-16.
- Palumbi SR (1994) Genetic divergence, reproductive isolation, and marine speciation. *Annual Review of Ecology and Systematics*, 25, 547-572.
- Pardo BG, Machordom A, Foresti F, *et al.* (2005) Phylogenetic analysis of flatfish (Order Pleuronectiformes) based on mitochondrial 16s rDNA sequences. *Scientia Marina*, 69, 531-543.
- Pardoe H, Marteinsdóttir G (2009) Contrasting trends in two condition indices: bathymetric and spatial variation in autumn condition of Icelandic cod (*Gadus morhua*). *Journal of Fish Biology*, 75, 282-289.
- Park K-I, Choi K-S (2001) Spatial distribution of the protozoan parasite *Perkinsus* sp. found in the Manila clams (*Ruditapes philippinarum*) in Korea. *Aquaculture*, 203, 9-22.
- Patarnello T, Volckaert FAMJ, Castilho R (2007) Pillars of Hercules: is the Atlantic-Mediterranean transition a phylogeographical break? *Molecular Ecology*, 16, 4426-4444.

- Pauly D (1995) Anecdotes and the shifting baseline syndrome of fisheries. *Trends in Ecology & Evolution*, 10, 430.
- Pauly D, Christensen V, Guenette S, *et al.* (2002) Towards sustainability in world fisheries. *Nature*, 418, 689-695.
- Pauly D, Watson R, Alder J (2005) Global trends in world fisheries: impacts on marine ecosystems and food security. *Philosophical Transactions of the Royal Society B: Biological Sciences*, 360, 5-12.
- Pauly D, Belhabib D, Blomeyer R, *et al.* (2013) China's distant-water fisheries in the 21st century. *Fish and Fisheries*: doi: 10.1111/faf.12032
- Pavlidis M, Koumoundouros G, Steriotti A, *et al.* (2000) Evidence of temperature-dependent sex determination in the European sea bass (*Dicentrarchus labrax*). *Journal of Experimental Zoology*, 287, 225-232.
- Pérez-Casanova JC, Rise ML, Dixon B, *et al.* (2008) The immune and stress responses of Atlantic cod to long-term increases in water temperature. *Fish & Shellfish Immunology*, 24, 600-609.
- Person-Le-Ruyet J, Baudin-Laurencin F, Devauchelle N (1991) Culture of turbot (*Scophthalmus maximus*). In: CRC Handbook of Mariculture, pp. 21-41. CRC Press, Boston, MA, USA.
- Petersen AC, Cath A, Hage M, Kunseler E, van der Sluijs JP (2011) Post-normal science in practice at the Netherlands environmental assessment agency. *Science, Technology & Human Values*, 36, 362-388.
- Petter Johnsen J, Eliassen S (2011) Solving complex fisheries management problems: What the EU can learn from the Nordic experiences of reduction of discards. *Marine Policy*, 35, 130-139.
- PEW (2009) Regional Governance: making it work for fisheries and the environment., pp. 51.
- Phillipson J, Lowe P, Proctor A, Ruto E (2012) Stakeholder engagement and knowledge exchange in environmental research. *Journal of Environmental Management*, 95, 56-65.
- Pielke R (2007) *The honest broker: Making sense of science in policy and politics*. Cambridge University Press, Cambridge.
- Pikitch EK, Santora C, Babcock EA, *et al.* (2004) Ecosystem-based fishery management. *Science*, 305, 346-347.
- Pingree RD, Holligan PM, Mardell GT (1978) The effects of vertical stability on phytoplankton distributions in the summer on the northwest European Shelf. *Deep Sea Research*, 25, 1011-1028.
- Pinho C, Hey J (2010) Divergence with gene flow: Models and data. In: *Annual Review of Ecology, Evolution, and Systematics*, Vol 41 (eds. Futuyama DJ, Shafer HB, Simberloff D), pp. 215-230.
- Pinsky ML, Palumbi SR (2013) Meta-analysis reveals lower genetic diversity in overfished populations. *Molecular Ecology*, 29, 29-39.
- Pita A, Pérez M, Cerviño S, Presa P (2011) What can gene flow and recruitment dynamics tell us about connectivity between European hake stocks in the Eastern North Atlantic? *Continental Shelf Research*, 31, 376-387.
- Planes S, Lenfant P (2002) Temporal change in the genetic structure between and within cohorts of a marine fish (*Diplodus sargus*) induced by a large variance in individual reproductive success. *Molecular Ecology*, 11, 1515-1524.
- Poos JJ, Bogaards JA, Quirijns FJ, Gillis DM, Rijnsdorp AD (2010) Individual quotas, fishing effort allocation, and over-quota discarding in mixed fisheries. *ICES Journal of Marine Science: Journal du Conseil*, 67, 323-333.
- Poulsen NA, Hemmer-Hansen J, Loeschcke V, Carvalho GR, Nielsen EE (2011) Microgeographical population structure and adaptation in Atlantic cod (*Gadus morhua*): spatio-temporal insights from gene-associated DNA markers. *Marine Ecology-Progress Series*, 436, 231-243.
- Pritchard JK, Stephens M, Donnelly P (2000) Inference of population structure using multilocus genotype data. *Genetics*, 155, 945-959.
- Proctor MF, McLellan BN, Strobeck C, Barclay RMR (2004) Gender-specific dispersal distances of grizzly bears estimated by genetic analysis. *Canadian Journal of Zoology-Revue Canadienne De Zoologie*, 82, 1108-1118.
- Pujolar JM, Maes GE, Volckaert FAM (2006) Genetic patchiness among recruits in the European eel *Anguilla anguilla*. *Marine Ecology Progress Series*, 307, 209-217.
- Punt A, Hilborn RAY (1997) Fisheries stock assessment and decision analysis: the Bayesian approach. *Reviews in Fish Biology and Fisheries*, 7, 35-63.
- Rae BB, Devlin SDE (1972) The turbot, its fishery and biology in the Scottish area. *Marine Research, Department of Agriculture and Fisheries for Scotland*, pp. 1-27.
- Raeymaekers JAM, Huyse T, Maelfait H, Hellemans B, Volckaert FAM (2008) Community structure, population structure and topographical specialisation of *Gyrodactylus* (Monogenea) ectoparasites living on sympatric stickleback species. *Folia parasitologica*, 55, 187-196.
- Ralston S, O'Farrell MR (2008) Spatial variation in fishing intensity and its effect on yield. *Canadian Journal of Fisheries and Aquatic Sciences*, 65, 588-599.
- Raymond M, Rousset F (1995) Genepop (Version-1.2) - population-genetics software for exact tests and ecumenicism. *Journal of Heredity*, 86, 248-249.
- Reiss H, Hoarau G, Dickey-Collas M, Wolff WJ (2009) Genetic population structure of marine fish: mismatch between biological and fisheries management units. *Fish and Fisheries*, 10, 1-35.

- Rice J, Cooper JA (2003) Management of flatfish fisheries-what factors matter? *Journal of Sea Research*, 50, 17.
- Rice JC, Rochet M-J (2005) A framework for selecting a suite of indicators for fisheries management. *ICES Journal of Marine Science: Journal du Conseil*, 62, 516-527.
- Rice J, de Fátima Borges M, Grehan A, *et al.* (2010) Science dimensions of an Ecosystem Approach to Management of Biotic Ocean Resources (SEAMBOR). *Marine Board-ESF*, pp. 92.
- Rice J (2011) Managing fisheries well: delivering the promises of an ecosystem approach. *Fish and Fisheries*, 12, 209-231.
- Rice WR (1989) Analyzing tables of statistical tests. *Evolution*, 43, 223-225.
- Ricker WE (1975) Computation and interpretation of biological statistics of fish populations. *Bulletin of the Fisheries Research Board of Canada*, 191, 385.
- Riegman R, Malschaert H, Colijn F (1990) Primary production of phytoplankton at a frontal zone located at the northern slope of the Dogger Bank (North Sea). *Marine Biology*, 105, 329-336.
- Rijnsdorp AD (1991) Changes in fecundity of female North Sea plaice (*Pleuronectes platessa*) between three periods since 1900. *ICES Journal of Marine Science: Journal du Conseil*, 48, 253-280.
- Rijnsdorp AD, Van Beek FA, Flatman S, *et al.* (1992) Recruitment of sole stocks (*Solea solea*) in the Northeast Atlantic. *Netherlands Journal of Sea Research*, 29, 173-192.
- Rijnsdorp AD, Witthames PR (2005) Ecology of reproduction. In: *Flatfishes: Biology and Exploitation* (ed. Gibson RN), pp. 68-93. Blackwell Scientific Press, London.
- Riley J, Symonds D, Woolner L (1981) On the factors influencing the distribution of 0-group demersal fish in coastal waters. pp.223-228.
- Risse T, Cowles GM, Caporaso J (2001) Europeanization and domestic change: Introduction. In: *Transforming Europe - Europeanization and Domestic Change* (eds. Cowles GM, Caporaso J, Risse T), pp. 1-20. Cornell University Press, Ithaca, NY.
- Roberge, J.-M. and P. E. R. Angelstam. 2004. Usefulness of the Umbrella Species Concept as a Conservation Tool. *Conservation Biology* 18, 76-85.
- Roel BA, De Oliveira JAA, Beggs S (2009) A two-stage biomass model for Irish Sea herring allowing for additional variance in the recruitment index caused by mixing of stocks. *Ices Journal of Marine Science*, 66, 1808-1813.
- Rogers AR, Harpending H (1992) Population growth makes waves in the distribution of pairwise genetic differences. *Molecular Biology and Evolution*, 9, 552-569.
- Rogers SI, Clarke KR, Reynolds JD (1999) The taxonomic distinctness of coastal bottom-dwelling fish communities of the North-east Atlantic. *Journal of Animal Ecology*, 68,769-782.
- Ronquist F, Huelsenbeck JP (2003) MrBayes 3: Bayesian phylogenetic inference under mixed models. *Bioinformatics*, 19, 1572-1574.
- Rosenberg AA (2007) Fishing for certainty. *Nature*, 449, 989-989.
- Rotmans J, van Asselt MBA (1996) Integrated assessment: A growing child on its way to maturity. *Climate Change*, 34, 327-336.
- Roy D, Hurlbut TR, Ruzzante DE (2012) Biocomplexity in a demersal exploited fish, white hake (*Urophycis tenuis*): depth-related structure and inadequacy of current management approaches. *Canadian Journal of Fisheries and Aquatic Sciences*, 69, 415-429.
- Ruddle K (1996) Traditional marine resources management systems in the Asia-Pacific region: design principles and policy options. *FAO*, pp. 295-312.
- Saarinen K, Monar J (2012) CFP Reform: A fresh approach or a fishy reluctance to conservation?, *College of Europe*.
- Sailliant E, Fostier A, Haffray P, *et al.* (2002) Temperature effects and genotype-temperature interactions on sex determination in the European sea bass (*Dicentrarchus labrax*). *Journal of Experimental Zoology*, 292, 494-505.
- Salamon L (2002) *The tools of governance: a guide to the new governance*. Oxford University Press.
- Sánchez-Molano E, Cerna A, Toro MA, *et al.* (2011) Detection of growth-related QTL in turbot (*Scophthalmus maximus*). *Bmc Genomics*, 12, 473.
- Sá-Pinto A, Branco MS, Alexandrino PB, Fontaine MC, Baird SJE (2012) Barriers to gene flow in the marine environment: Insights from two common intertidal limpet species of the Atlantic and Mediterranean. *PLoS ONE*, 7, e50330.
- Sardà F, Coll M, Heymans JJ, Stergiou KI (2013) Overlooked impacts and challenges of the new European discard ban. *Fish and Fisheries*: doi: 10.1111/faf.12060.
- Scharpf FW (1997) *Games real actors play - actor-centered institutionalism in policy research*. Westview Press, Boulder (Colorado).
- Scheffer M, Carpenter S, Young Bd (2005) Cascading effects of overfishing marine systems. *Trends in ecology & evolution* (Personal edition), 20, 579-581.

- Schindler DE, Hilborn R, Chasco B, *et al.* (2010) Population diversity and the portfolio effect in an exploited species. *Nature*, 465, 609-612.
- Schmidt HA, Strimmer K, Vingron M, von Haeseler A (2002) TREE-PUZZLE: maximum likelihood phylogenetic analysis using quartets and parallel computing. *Bioinformatics*, 18, 502-504.
- Schrope M (2010) Fisheries: What's the catch? *Nature*, 465, 540-542.
- Schrum C, Siegismund F, John MS (2003) Decadal variations in circulation and stratification pattern of the North Sea. Are the 90's unusual? In: ICES Journal of Marine Science, Symposia Series, pp. 121-131.
- Schunter C, Carreras-Carbonell J, Macpherson E, *et al.* (2011) Matching genetics with oceanography: directional gene flow in a Mediterranean fish species. *Molecular Ecology*, 20, 5167-5181.
- Schwach V, Bailly D, Christensen AS, *et al.* (2007) Policy and knowledge in fisheries management: a policy brief. *ICES Journal of Marine Science: Journal du Conseil*, 64, 798-803.
- Schwartz M, McKelvey K (2009) Why sampling scheme matters: the effect of sampling scheme on landscape genetic results. *Conservation Genetics*, 10, 441-452.
- Selkoe KA, Gaines SD, Caselle JE, Warner RR (2006) Current shifts and kin aggregation explain genetic patchiness in fish recruits. *Ecology*, 87, 3082-3094.
- Selkoe KA, Henzler CM, Gaines SD (2008) Seascape genetics and the spatial ecology of marine populations. *Fish and Fisheries*, 9, 363-377.
- Selkoe KA, Watson JR, White C, *et al.* (2010) Taking the chaos out of genetic patchiness: seascape genetics reveals ecological and oceanographic drivers of genetic patterns in three temperate reef species. *Molecular Ecology*, 19, 3708-3726.
- Selkoe KA, Toonen RJ (2011) Marine connectivity: a new look at pelagic larval duration and genetic metrics of dispersal. *Marine Ecology Progress Series*, 436, 291-305.
- Sevilla RG, Diez A, Noren M, *et al.* (2007) Primers and polymerase chain reaction conditions for DNA barcoding teleost fish based on the mitochondrial cytochrome b and nuclear rhodopsin genes. *Molecular Ecology Notes*, 7, 730-734.
- Sharma S, Legendre P, Boisclair D, Gauthier S (2012) Effects of spatial scale and choice of statistical model (linear versus tree-based) on determining species-habitat relationships. *Canadian Journal of Fisheries and Aquatic Sciences*, 69, 2095-2111.
- Silvestro D, Michalak I (2012) raxmlGUI: a graphical front-end for RAxML. *Organisms Diversity & Evolution*, 12, 335-337.
- Sivasundar A, Palumbi S (2010) Life history, ecology and the biogeography of strong genetic breaks among 15 species of Pacific rockfish, *Sebastes*. *Marine Biology*, 157, 1433-1452.
- Skagen & Hauge Sa (2002) Recent development of methods for analytical fish stock assessment within ICES, pp. 215.
- Slatkin M, Hudson RR (1991) Pairwise comparisons of mitochondrial DNA sequences in stable and exponentially growing populations. *Genetics*, 129, 555-562.
- Smit W (2001) Dutch demersal North Sea fisheries: initial allocation of flatfish ITQs. In: Case studies on the allocation of transferable quota rights in fisheries (ed. Shotton R), pp. 411. FAO Fisheries Technical Paper.
- Smith ADM, Sainsbury KJ, Stevens RA (1999) Implementing effective fisheries-management systems - management strategy evaluation and the Australian partnership approach. *ICES Journal of Marine Science: Journal du Conseil*, 56, 967-979.
- Smith PE, Horne JK, Schneider DC (2001) Spatial dynamics of anchovy, sardine, and hake pre-recruit stages in the California Current. *ICES Journal of Marine Science: Journal du Conseil*, 58, 1063-1071.
- Sparholt H, Bertelsen M, Lassen H (2007) A meta-analysis of the status of ICES fish stocks during the past half century. *ICES Journal of Marine Science: Journal du Conseil*, 64, 707-713.
- Stamatakis A (2006) RAxML-VI-HPC: maximum likelihood-based phylogenetic analyses with thousands of taxa and mixed models. *Bioinformatics*, 22, 2688-2690.
- Stankus S (2003) The peculiarities of turbot (*Psetta maxima*) biology and their role in the ecosystem of the Baltic Sea coastal zone of Lithuania. *Acta Zoologica Lituonica*, 13, 217-238.
- Star B, Nederbragt AJ, Jentoft S, *et al.* (2011) The genome sequence of Atlantic cod reveals a unique immune system. *Nature*, 477, 207-210.
- STECF (2012a) Different principles for defining selectivity under the future TM regulations (STECF-12-20). pp.64.
- STECF (2012b) Review of proposed DCF 2014-2020 PART 1 (STECF-12-07). pp.70.
- STECF (2013) Summary of the 2013 annual economic report on the EU fishing fleet (STECF-13-18). pp.32.
- Storz JF, Bhat HR, Kunz TH (2001) Genetic consequences of polygyny and social structure in an Indian fruit bat (*Cynopterus sphinx* l.). Inbreeding, outbreeding and population subdivision. *Evolution*, 55, 1215-1223.

- Storz JF (2005) Invited Review: Using genome scans of DNA polymorphism to infer adaptive population divergence. *Molecular Ecology*, 14, 671-688.
- Stottrup JG, Sparrevohn CR, Modin J, Lehmann K (2002) The use of releases of reared fish to enhance natural populations - A case study on turbot (*Psetta maxima*) (Linné, 1758). *Fisheries Research*, 59, 161-180.
- Stouten (2010) Learning from a microworld in fisheries management: the Belgian fisheries system., Ghent University.
- Strimmer K, von Haeseler A (1997) Likelihood-mapping: A simple method to visualize phylogenetic content of a sequence? alignment. *Proceedings of the National Academy of Sciences*, 94, 6815-6819.
- Suuronen P, Sardà F (2007) The role of technical measures in European fisheries management and how to make them work better. *ICES Journal of Marine Science: Journal du Conseil*, 64, 751-756.
- Suzuki N, Nishida M, Yoseda K, *et al.* (2004) Phylogeographic relationships within the Mediterranean turbot inferred by mitochondrial DNA haplotype variation. *Journal of Fish Biology*, 65, 580-585.
- Swart JAA, Van Andel J (2008) Rethinking the interface between ecology and society. The case of the cockle controversy in the Dutch Wadden Sea. *Journal of Applied Ecology*, 45, 82-90.
- Symes D, Hoefnagel E (2010) Fisheries policy, research and the social sciences in Europe: Challenges for the 21st century. *Marine Policy*, 34, 268-275.
- Tajima F (1989) Statistical method for testing the neutral mutation hypothesis by DNA polymorphism. *Genetics*, 123, 585-595.
- Tamura K, Peterson D, Peterson N, *et al.* (2011) MEGA5: Molecular evolutionary genetics analysis using maximum likelihood, evolutionary distance and maximum parsimony methods. *Molecular Biology and Evolution*, 2731-2739.
- Teacher AGF, André C, Jonsson PR, Merilä J (2013) Oceanographic connectivity and environmental correlates of genetic structuring in Atlantic herring in the Baltic Sea. *Evolutionary Applications*, 6, 549-567.
- Teal LR, van Hal R, van Kooten T, Ruardij P, Rijnsdorp AD (2012) Bio-energetics underpins the spatial response of North Sea plaice (*Pleuronectes platessa*) and sole (*Solea solea*) to climate change. *Global Change Biology*, 18, 3291-3305.
- Therkildsen NO, Nielsen EE, Swain DP, Pedersen JS (2010) Large effective population size and temporal genetic stability in Atlantic cod (*Gadus morhua*) in the southern Gulf of St. Lawrence. *Canadian Journal of Fisheries and Aquatic Sciences*, 67, 1585-1595.
- Tilman D (1996) Biodiversity: Population Versus Ecosystem Stability. *Ecology*, 77, 350-363.
- Tonsor SJ (2012) Population genomics and the causes of local differentiation. *Molecular Ecology*, 21, 5393-5395.
- Toth AL, Varala K, Newman TC, *et al.* (2007) Wasp gene expression supports an evolutionary link between maternal behavior and eusociality. *Science*, 318, 441-444.
- Tremblay-Boyer L, Gascuel D, Watson R, Christensen V, Pauly D (2011) Modelling the effects of fishing on the biomass of the world's oceans from 1950 to 2006. *Marine Ecology Progress Series*, 442, 169-185.
- Turrell WR (2004) The policy basis of the "Ecosystem approach" to fisheries management. pp.32.
- Ulrich C, Reeves SA, Vermard Y, Holmes SJ, Vanhee W (2011) Reconciling single-species TACs in the North Sea demersal fisheries using the Fcube mixed-fisheries advice framework. *ICES Journal of Marine Science: Journal du Conseil*, 2-13.
- Ulrich C, Boje J, Cardinale M, *et al.* (2013) Variability and connectivity of plaice populations from the Eastern North Sea to the Western Baltic Sea, and implications for assessment and management. *Journal of Sea Research*, 40-48.
- UNEP (2002) A step towards a sustainable future. pp.64.
- United Nations (2002) Report on the world summit on sustainable development (A/CONF.199/20). In: World Summit on Sustainable Development, pp. 173. United Nations, Johannesburg, South Africa.
- van Damme CJG (2013) Don't put all your eggs in one basket! Reproductive strategies and fecundity regulation in temperate marine teleosts, Wageningen University, pp. 183.
- Van Damme J, Brans M, Fobé E (2011) Balancing expertise, societal input and political control in the production of policy advice. A comparative study of education councils in Europe. *Halduskultuur - Administrative Culture*, 12, 126-145.
- van der Hammen T, Poos JJ, van Overzee HJM, *et al.* (2013) Population ecology of turbot and brill: What can we learn from two rare flatfish species? *Journal of Sea Research*, 84, 96-108.
- Van der Land MA (1991) Distribution of flatfish eggs in the 1989 egg surveys in the southeastern North Sea, and mortality of plaice and sole eggs. *Netherlands Journal of Sea Research*, 27, 277-286.
- van der Sluijs JP, Arthur CP, Janssen PHM, Risbey JS, Ravetz JR (2008) Exploring the quality of evidence for complex and contested policy decisions. *Environmental Research Letters*, 3, 10.

- Van der Veer HW, Berghahn R, Miller JM, Rijnsdorp AD (2000) Recruitment in flatfish, with special emphasis on North Atlantic species: Progress made by the Flatfish Symposia. *Ices Journal of Marine Science*, 57, 202-215.
- Van Der Windt HJ, Swart JAA (2008) Ecological corridors, connecting science and politics: the case of the Green River in the Netherlands. *Journal of Applied Ecology*, 45, 124-132.
- Van Hoof L (2013) Design or pragmatic evolution: applying ITQs in EU fisheries management. *ICES Journal of Marine Science: Journal du Conseil*, 70, 462-470.
- van Oosterhout C, Hutchinson WF, Wills DPM, Shipley P (2004) MICRO-CHECKER: software for identifying and correcting genotyping errors in microsatellite data. *Molecular Ecology Notes*, 4, 535-538.
- van Walraven L, Mollet FM, van Damme CJG, Rijnsdorp AD (2010) Fisheries-induced evolution in growth, maturation and reproductive investment of the sexually dimorphic North Sea plaice (*Pleuronectes platessa* L.). *Journal of Sea Research*, 64, 85-93.
- Vandamme SG, Maes GE, Raeymaekers JAM, et al. (2013) Regional environmental pressure influences population differentiation in turbot (*Scophthalmus maximus*). *Molecular Ecology*: doi: 10.1111/mec.12628.
- Vasemägi A (2006) The adaptive hypothesis of clinal variation revisited: Single-locus clines as a result of spatially restricted gene flow. *Genetics*, 173, 2411-2414.
- Vilas R, Bouza C, Vera M, Millan A, Martinez P (2010) Variation in anonymous and EST-microsatellites suggests adaptive population divergence in turbot. *Marine Ecology-Progress Series*, 420, 231-239.
- Vogler J (2000) *The global commons - environmental and technological governance*, 2 edn. John Wiley & Sons Ltd, Chichester.
- Volckaert FAM (2012) (Flat)fish stocks in an ecosystem and evolutionary perspective. *Journal of Sea Research*, 19-32.
- Voronina EP (2010) On morphology and taxonomy of scophthalmids. *Journal of Ichthyology*, 50, 695-703.
- Walters CJ, Martell SJD (2004) *Fisheries ecology & management*. Princeton University Press.
- Walton MJ (1997) Population structure of harbour porpoises *Phocoena phocoena* in the seas around the UK and adjacent waters. *Proceedings of the Royal Society B-Biological Sciences*, 264, 89-94.
- Waples RS (1989) A generalized approach for estimating effective population size from temporal changes in allele frequency. *Genetics*, 121, 379-391.
- Waples R (1998) Separating the wheat from the chaff: patterns of genetic differentiation in high gene flow species. *Journal of Heredity*, 89, 438-450.
- Waples RS (2006) A bias correction for estimates of effective population size based on linkage disequilibrium at unlinked gene loci. *Conservation Genetics*, 7, 167-184
- Waples RS, Gaggiotti O (2006) What is a population? An empirical evaluation of some genetic methods for identifying the number of gene pools and their degree of connectivity. *Molecular Ecology*, 15, 1419-1439.
- Waples RS, Punt AE, Cope JM (2008) Integrating genetic data into management of marine resources: how can we do it better? *Fish and Fisheries*, 9, 423-449.
- Waples R, Naish K (2009) Genetic and evolutionary considerations in fishery management: research needs for the future. In: *The Future of Fisheries Science in North America* (eds. Beamish R, Rothschild B), pp. 427-451. Springer Netherlands.
- Ward RD, Woodwark M, Skibinski DOF (1994) A comparison of genetic diversity levels in marine, fresh-water and anadromous fishes. *Journal of Fish Biology*, 44, 213-232.
- Ward RD (2000) Genetics in fisheries management. *Hydrobiologia*, 420, 191-201.
- Was A, Gosling E, Hoarau G (2010) Microsatellite analysis of plaice (*Pleuronectes platessa*) in the NE Atlantic: weak genetic structuring in a milieu of high gene flow. *Marine Biology*, 157, 447-462.
- Watson RT (2005) Turning science into policy: challenges and experiences from the science-policy interface. *Philosophical Transactions of the Royal Society London B Biological Science*, 28, 471-477.
- Weir BS, Cockerham CC (1984) Estimating F-statistics for the analysis of population-structure. *Evolution*, 38, 1358-1370.
- Wennevik V, Jørstad KE, Dahle G, Færevolden SE (2008) Mixed stock analysis and the power of different classes of molecular markers in discriminating coastal and oceanic Atlantic cod (*Gadus morhua* L.) on the Lofoten spawning grounds, Northern Norway Challenges to Marine Ecosystems. (eds. Davenport J, Burnell GM, Cross T, et al.), pp. 7-25, Springer Netherlands.
- White C, Selkoe KA, Watson J, et al. (2010a) Ocean currents help explain population genetic structure. *Proceedings of the Royal Society B-Biological Sciences*, 277, 1685-1694.
- White JW, Botsford LW, Moffitt EA, Fischer DT (2010b) Decision analysis for designing marine protected areas for multiple species with uncertain fishery status. *Ecological Applications*, 20, 1523-1541.
- Wicker T, Schlagenhauf E, Graner A, et al. (2006) 454 sequencing put to the test using the complex genome of barley. *Bmc Genomics*, 7, 275.

- Wilczek AM, Roe JL, Knapp MC, *et al.* (2009) Effects of genetic perturbation on seasonal life history plasticity. *Science*, 323, 930-934.
- Wilson AB, Veraguth IE (2010) The impact of Pleistocene glaciation across the range of a widespread European coastal species. *Molecular Ecology*, 19, 4535-4553.
- Wilson D (2009) The paradoxes of transparency science and the ecosystem approach to fisheries management in Europe. Amsterdam University Press.
- Wimpenny RS (1953) *The plaice*. Edward Arnold & Co, London.
- World Bank (2009) *The sunken billions: The economic justification for fisheries reform*. The International Bank for Reconstruction and Development / The World Bank, p. 130.
- Worm B, Barbier EB, Beaumont N, *et al.* (2006) Impacts of biodiversity loss on ocean ecosystem services. *Science*, 314, 787-790.
- Worm B, Hilborn R, Baum JK, *et al.* (2009) Rebuilding global fisheries. *Science*, 325, 578-585.
- Xia X (2013) DAMBE5: A comprehensive software package for data analysis in molecular biology and evolution. *Molecular Biology and Evolution*, 30, 1720-1728.
- Yamashita Y, Tanaka M, Miller JM (2001) Ecophysiology of juvenile flatfish in nursery grounds. *Journal of Sea Research*, 45, 205-218.
- Yeaman S, Otto SP (2011) Establishment and maintenance of adaptive genetic divergence under migration, selection and drift. *Evolution*, 65, 2123-2129.
- Young OR (1989) Science and social institutions: lessons for international resource regimes. In: *International Resource Management: the role of science and politics* (eds. Andressen S, Ostreng W), pp. 7-24. Belhaven Press, London.
- Young OR (1997) Global governance: toward a theory of decentralized world order. In: *Global Governance* (ed. Young), pp. 273-300. The MIT Press, Cambridge and London.
- Zink RM (1996) Comparative phylogeography in North American birds. *Evolution*, 50, 308-317.

