

Hybrid thermo-chemical district networks – Principles, technology and economic feasibility

Philipp Geyer^{a, d, *}, Martin Buchholz^{b, d}, Reiner Buchholz^{c, d}, Mathieu Provost^b

^a Architectural Engineering Division, KU Leuven, Leuven, Belgium

^b Institut für Architektur, TU Berlin, Berlin, Germany

^c Institut für Energietechnik, TU Berlin, Berlin, Germany

^d Watergy GmbH, Berlin, Germany

* Corresponding author. Email: p.geyer@kuleuven.be, Tel.: +32 16 32 69 59

Abstract

Low-temperature residual heat and heat potentials of renewables below 70°C often stay unused as either the distance between source and demand is too large or the heat does not occur at demand times. Hybrid thermo-chemical networks have a high potential to improve this situation, to transport thermal energy potential over long distances and to bridge short to medium time differences between demand and supply. The storage and transport potential of thermo-chemical substances has been identified and examined comprehensively. However, none of the studies addressed the replacement of water by thermo-chemical fluids (TCF) in district networks. Therefore this paper elaborates the use of TCF in such networks. First, it elaborates technological application cases showing the theoretical potential to reduce primary energy consumption up to 85%. Second, it presents technological components that have been developed for thermo-chemical systems.

Keywords Open Thermo-chemical Sorption Technology; District Networks for Heating, Cooling and Drying; Residual Heat Usage; Solar Thermal Energy; Systems Engineering.

1 Introduction

A growing demand for secure sustainable energy supply with low resource consumption and low emissions requires the exploitation of previously unused sources of residual heat and residual renewables, especially at low levels of temperatures. Whereas low energy-demand of buildings allows the use of heating systems working with low supply temperatures, the problems associated with transport of low-temperature heat persist. Heat losses during transport are limiting the usage of low-temperature heat to near distance heat networks with a radius of only a few hundred meters. This restricts the use of low temperature heat to specific cases, in which heat source and heat consumers are located close together and schedules of

available heat and demand match. Under these conditions, in most cases, the large potential of residual heat remains unused.

The aim of the ongoing research presented in this paper is to examine technology and business cases for district energy system based on thermo-chemical fluids (TCF). This new technology will contribute to the optimal use of energy resources, particularly low-grade residual heat and thermal renewables. By making these energy sources available, which are not exploitable by conventional district heating technology, thermo-chemical energy networks contribute to sustainable energy systems. Rather than on focusing on thermo-chemical processes that are known from fundamental research the paper focusses on the integration of the technology in the context of the built environment and the given waste heat sources.

This novel type of district energy network uses a liquid desiccant as thermo-chemical fluid (TCF) for the purpose of energy potential transport. Low-grade heat is used for TCF regeneration, a process in that water is evaporated out of the TCF, providing a concentrate. This concentrate can be used as an energy potential carrier for transport and storage. The benefits for a sustainable energy system that will be substantiated in the paper are:

- Exploitation of unused low-grade residual heat,
- Loss-free long-distance transport and medium-term storage and
- Higher economic value by extended services.

The novelty of the paper is that it presents a scenario for the use of thermo-chemical is district networks. Whereas the potential of thermo-chemical substances in energy storage and transport has been recognized, thermo-chemical networks have not been examined in terms of their technological and economic application potential up to now. Most research, which is compiled in the next section, focuses on the storage aspect and only adds the remark that also transport of the storage is possible. Furthermore, transport of residual heat has been realized only at a small prototypical scale with PCM fluids or solid thermo-chemical storage on a container-and-truck basis. None of the studies tackles the modelling, analysis and realization of a multi-functional pipe-based network similar to water-based district heating and cooling networks based on a TCF. The paper starts to explore potential by developing and modelling a multi-functional application scenario, examining the energetic advantage with respect to reduction of primary energy demand and the technological and economic feasibility.

Section 2 provides a survey of existing technology approaches to thermo-chemical technology as it is relevant for district energy networks. Section 3 introduces the principles of the thermo-chemical network technology. Section 4 applies a systems engineering and modelling approach to develop technological application cases and Section 5 carries out fundamental engineering of operation. Section 6 first tackles the realization with respect to developed network components.

2 Background

Residual heat and renewables have high volume especially at low and very low temperatures (Figure 1)a. A study [1] identifies an industry volume of around 20 TWh per year in Norway from that 64% are below 140°C and 47% are below 60°C. Pehnt et al. [2] state that economic

use of current thermal technology for residual heat recovery can come up for 6 to 12 % of the energy demand in German industry depending on the temperature level. Among such technologies, Walsh and Thornley [3] determine a favourable payback period of between 3 and 6 years for organic Rankine cycle (ORC) and condensing boiler technology. However, the currently tapped potentials of residual heat recovery are mainly based on local reuse within the industry and on the utilization based on thermal district networks. For instance, Law et al. [4] review technologies for local reuse of low-grade heat in food industry. For thermal district networks bridging longer distances, the temperature level is often too low and the energy losses and costs are too high to allow transport to further distant consumers, such as residential buildings that form a large portion of the thermal energy demand.

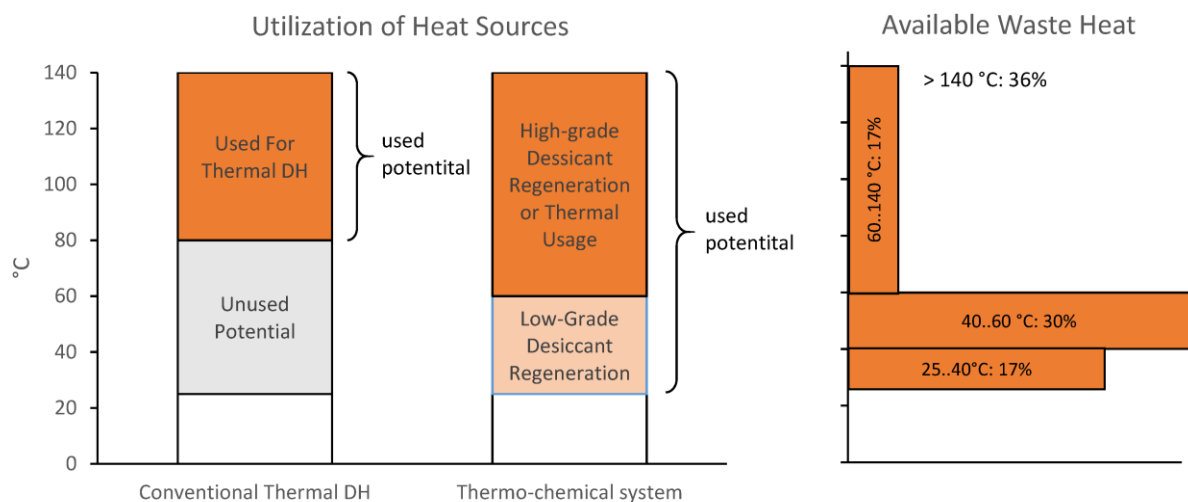

Figure 1: Estimated low-grade residual heat volume based on data from [1] and its aimed exploitation by thermo-chemical technology.

Due to these reasons, different studies examine the use of absorption processes and other thermo-chemical processes for the transport of residual heat. In a study of different transport processes for heat energy over long distances, Ma et al. [5] highlight adsorption and absorption besides phase-change materials as main mechanisms.

On the basis of ammonia, Kang et al. [6] describe and analyse a spatially distributed absorption heat pump process focussing on cooling with desorption temperature higher than 100°C. Lin et al. [7] lay out an ammonia-based transport system scenario based on experiments. Their economic analysis results in a payback period within 4 years. Kiani et al. 8, 9 and Ammar et al. [10] develop, examine and optimize this technology for residual heat transport. Ammar et al. recommend distances up to 30 to 40 km and determines for heating and cooling based on an ammonia-water system a coefficient of performance (COP) of approximately 0.5 (running closed absorption heat pumps). However, the ammonia-based network is not compatible with district technology as it uses a highly hazardous fluid and requires a closed refrigeration process.

Fluids for thermal energy storage using absorption or reversible chemical reactions driven by low-grade heat are of interest for thermo-chemical networks. However, most of the literature, deals with thermo-chemical storage materials focussing on local thermo-chemical storage

application. Reviews N'Tsoukpoe et al. [11], Yan et al. [12] and Kalaiselvam and Parameshwaran [13] well reflect the current state-of-the-art of thermo-chemical storage with some additional research worth noting [14, 15, 16, 17, 18]. Furthermore, there exists coupling of thermo-chemical storage with district heating systems for buffering [19]. Open sorption systems based on magnesium chloride $MgCl_2$, which is a cheap well-suited TCF, by [20, 21, 22, 23, 24]; examples of other salt solutions are also present [25, 26]. Transport is only marginally mentioned and specific long-distance transport related aspects, such as toxicity, play a subordinate role. Furthermore, N'Tsoukpoe et al. [27] examine possible salt hydrates for low-temperature heat storage from micro CHPs. Basciotti and Pol [28] propose and theoretically examine the coupling of a thermo-chemical storage to a district heating network for cooling purposes. However, also these studies do not examine a thermo-chemical district network but focus on the local storage aspect.

Container-based transport is taken into account and realized in a prototypical way. Mazet et al. [29] and Storch and Hauer [30] examine solid desiccants and PCMs for transport. Container solutions based on liquid PCM have been examined in detail and implemented as a prototype [31, 32, 33, 34, 35]. However, these solutions are not designed for pipe applications.

The use of the TCF for dehumidification, cooling and latent heat recovery from waste air is state of the art. These technologies perfectly suit to thermo-chemical networks. Dehumidification systems are well known since the early century and still applied [36, 37]. The main advantage is related to cooling applications, in which air does not need to be cooled down to the dew point, which make these technologies much more energy efficient. Furthermore, in many climatic situations dehumidification is a precaution for evaporative cooling [37]. Latent heat recovery systems work similar, while the heat is transferred from the exhaust air to the incoming air. A further technology for this purpose are membrane heat exchangers that allow to pass water fractions of the TCF from the incoming side to the outgoing side of an air to air heat exchanger.

From previous research of the authors' group, cases to use the technology for space heating by humid-air solar collectors have been examined [38]. Furthermore, a method of systems modelling for designing such complex systems at building level and at urban level was developed [39, 40].

3 Principles of thermo-chemical networks

By using TCF with high energy density in the state of TCF-concentrate, reuse or recycling of specific low-temperature amounts of residual heat becomes possible in the regeneration process. In a thermo-chemical network, the hygroscopic property of the TCF, mainly provided as salt solutions, is used to improve energy efficiency within industrial drying and air conditioning units. Furthermore, urban roof and facade greenhouses can serve as local renewable energy sources and providing large amounts of warm and humid air gained from solar radiation. The TCF converts humidity into usable sensible heat within attached buildings for heating purposes.

In the case of a network with several regeneration units, the exploration of disperse, local heat sources requires a qualitative and quantitative evaluation of heat potentials in terms of origin as well as spatial and temporal occurrence. As an example, within the Project “High Tech – Low Ex, Energy Efficiency Adlershof” [21] an energetic analysis of the project area showed a technically usable residual heat potential of several MW, which comes primarily from ventilation and air conditioning, and in the temperature range of 35-40° C. The low temperature level and the temporal fluctuations of the heat flux are interfering a recovery within conventional energy converters. For the purpose of source and demand management, the computer-aided technique of automated network identification can be used [41, 42].

Supply and demand peaks can be balanced via thermo-chemical storages. This allows to bridge time gaps between supply and demand. Storage and transport without thermal losses is a specific advantage of the whole approach. The energy density of a concentrated $MgCl_2$ solution—a common TCF, is about three to six times higher than the value of district heating systems. Taking together the advantages of energy density, thermo-chemical stability and buffering capacity of energetic potential within storages, much larger distances within a thermo-chemical network (compared to heat networks) can still be financially viable.

TCF based on hygroscopic salt solutions (particularly those based on $CaCl_2$, $MgCl_2$ and $LiCl_2$ salts) can be used for different drying processes and applications for the recovery of latent heat (see Figure 2).

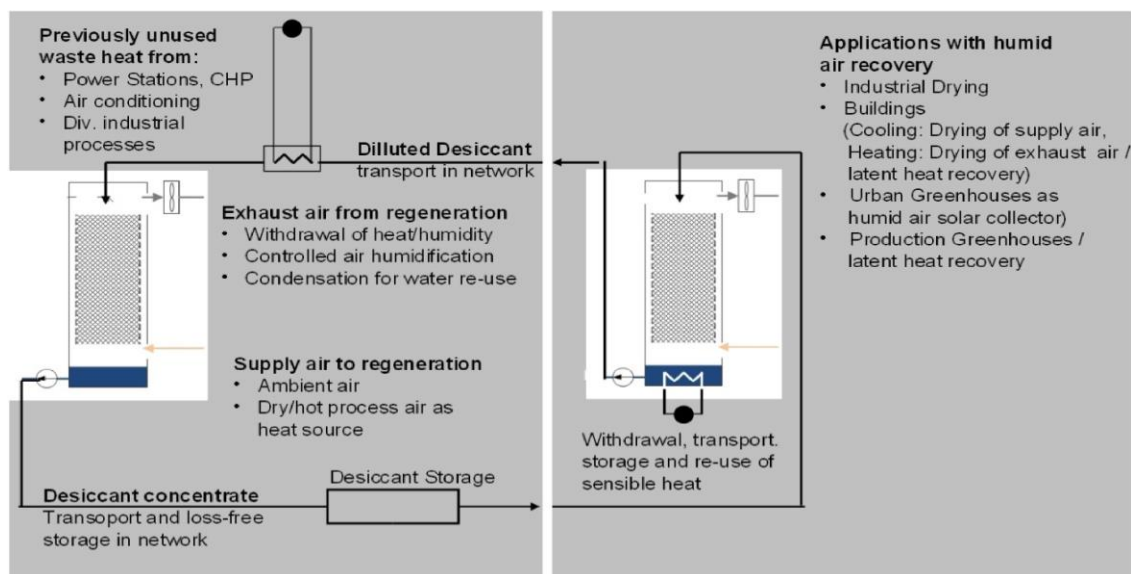

Figure 2: Use of residual heat sources for TCF regeneration (left) and activation of thermo-chemical energy through absorption of water vapor within different applications (right), connected by a network including a thermo-chemical storage.

The concentration of the TCF is described by its mass ratio. By an uptake of moisture, the brine is diluted and the concentration decreases. The ability to absorb water (hygroscopic property) decreases with increasing water content. From a certain degree of dilution, the brine has to be regenerated, which is the concentration of the salt content, by evaporating (desorbing) water out of the solution. This process needs sufficiently cheap thermal energy, e.g. from a residual heat source. Under supply of this heat, water is "desorbed" from the solution and can be removed in vapour phase by an air stream.

The temperature required for regeneration depends on the kind of salt used, on the required concentration and on the relative humidity of the passing air (which is again dependent to the air temperature). The relative humidity of the air is determined by the climatic conditions of the environment, but can be lowered by heating the air. Exhaust heat from industrial processes, from cooling towers of power plants or exhaust heat from refrigeration systems can be used for this purpose. Also heat from district heat networks low temperature return direction or at least temporarily unused excess heat from CHP units can be used. In winter, the regeneration of the salt solution can be performed even at very low-temperature heat (10-20° C), as the relative humidity of the cold outdoor air is correspondingly low. In this way, heat from near-surface soil or aquifer thermal storages can be qualified to serve such a network. The phase change from water vapour to liquid water taking place during absorption releases thermal energy (about 680 kWh per m³ water). This energy potential is stored in the solution concentrate's water uptake capability. The increased energy density and the elimination of thermal losses are the keys to bridge larger distances and to activate remote heat sources. Besides the distance between heat source and user, a thermo-chemical network solves problems concerning losses in time shifts between heat supply and heat utilization. Moreover, temperature levels of residual heat source and utilization may differ, which allows a broader range of applications. Further advantages are relating to the low cost of the salt solutions (especially in case of MgCl₂) and the hygiene properties of liquid desiccants that is in direct contact with process air.

4 Technological application cases

This section provides the fundamental systems engineering for the thermo-chemical network technology and defines potential application case that form the basis for the development of the technology. The systems engineering uses the systems modelling language (SysML, [43]) to start from requirements and use cases and to develop the outline for the four key features: (1) residual heat use for regeneration, (2) drying, (3) heating and (4) cooling.

4.1 Requirements and processes

The first step to lay out a hybrid thermo-chemical network technology is the determination of use cases and requirements. The chief characteristic use case of the system, as shown in Figure 3, consists in the reuse of low-grade residual heat. It is aimed to reuse residual heat that is currently unused, as they occur at CHP stations (30...120 °C), in data centres (30...50 °C) and, after other higher temperature uses, in large power stations or industrial production (30...80 °C) as well as renewable energy sources (20...50 °C) replacing or supplementing both dry and wet heat rejection. This leads to the requirement of a low temperature range and a wide media range. Furthermore, the schedule of available residual heat and demand do not match exactly, which requires medium-term storage between hours and days. Finally, a central requirement is the long-distance transport up to 50 km.

However, the reuse of low-grade residual heat and the district energy system needs at the same time to consider the demand side services. There are two major use cases: (1) air drying, which includes drying for air conditioning as well as industrial drying applications at higher

temperature levels, (2) heating and cooling, which all operate at lower temperature levels in building applications as well as within a larger temperature range, especially in industrial applications.

Figure 4 shows typical processes taking place in a thermo-chemical network. The processes start from the left with the sources of low-temperature heat (residual heat or renewables). This heat is first transformed to thermo-chemical potential; second, sensible heat is transferred to a transport medium, which can be the TCF itself, but can also be water in a parallel conventional district heating network. In these ways, heat energy is transferred to the network. With the warm concentrated TCF, three different processes are possible at the user's side: first, drying of air by absorption; second, heating by an absorption-driven heat transport; third, cooling by supply air dehumidification and indirect evaporative cooling, generated in the exhaust air. Whereas drying and cooling mainly relies on the hygroscopic potential of the TCF, heating uses both, the latent and the sensible heat potential from the secondary sensible transport. The use of sensible heat is possible as long as the heat source is not located too far away from the consumer. However, the main advantage is the latent loss-free transport with higher capacities and thus smaller pipes.

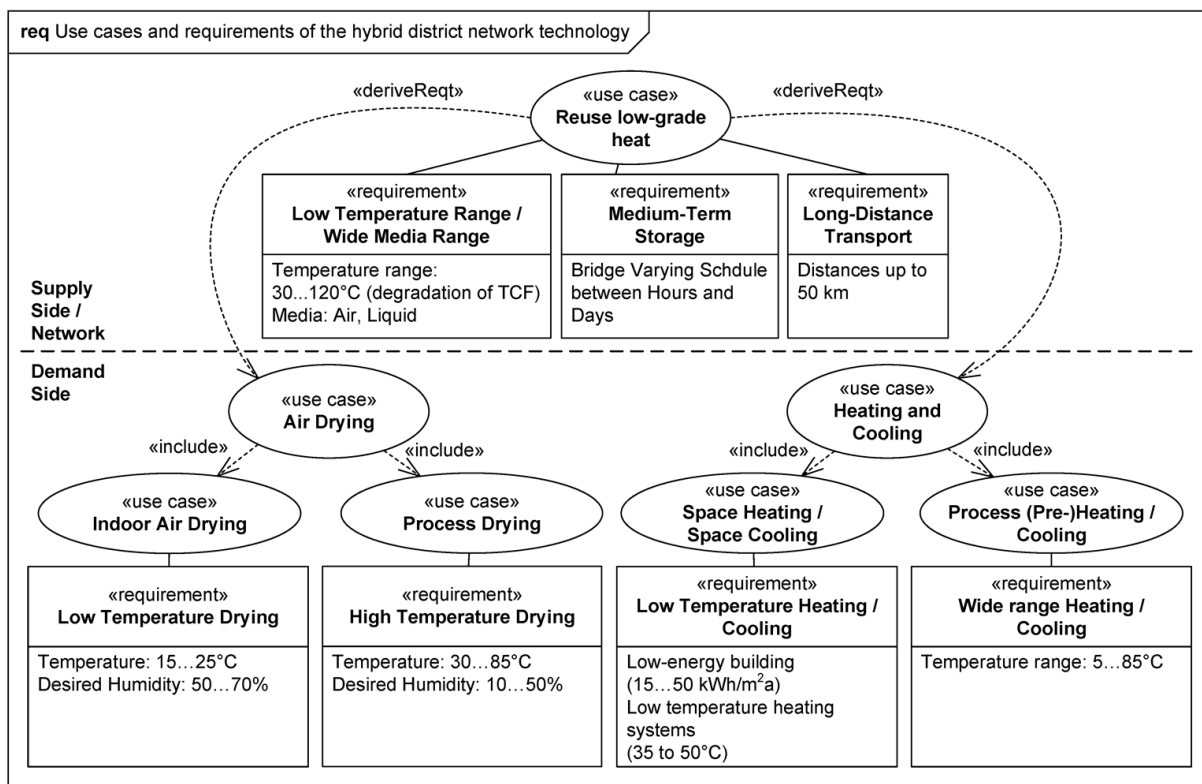

Figure 3: Requirements and use cases for a hybrid network.

The main function of the hybrid network is the control of different concentrations and temperatures of the fluid. This includes short-term and medium-term storage of thermo-chemical potential between days and weeks, which is an important requirement as residual heat is not available at the same time as it is demanded. For this purpose, the network requires a smart management to match the demand and the sources in time and location.

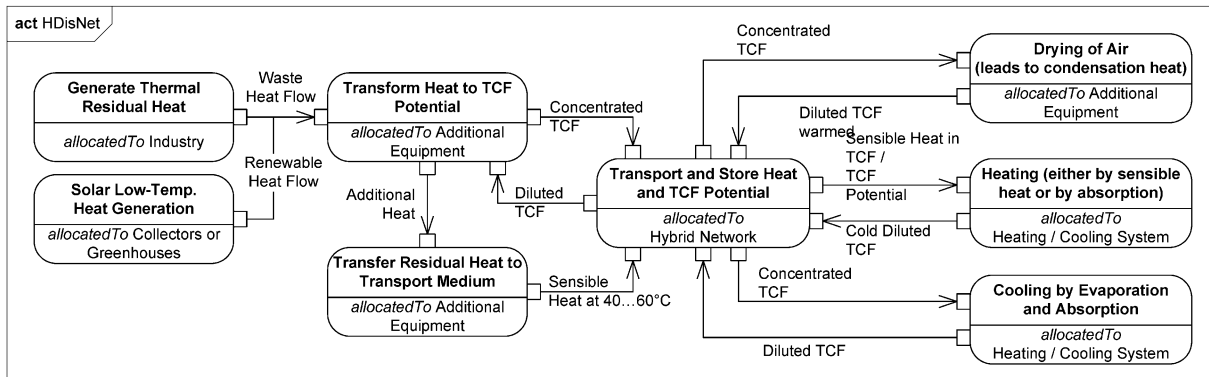

Figure 4: Processes in the hybrid thermo-chemical network.

4.2 System structure

Based on this process pattern, a generic layout of the structure is provided. Figure 5 shows a structure, in which the network transports thermo-chemical potential and sensible heat from a heat source at the left to consumers at the right. The figure is divided in three partitions, the source-side technology, the hybrid network and the demand-side technology. At the source side, the main required additional equipment is a combined desorber and heat exchanger. For this component, two different types are planned: One that extracts residual heat from a warm liquid, e.g. from cooling circuits, and one that works with hot air, e.g. exhaust air from server rooms. For the desorption process both types need to bring the TCF into contact with air. However, the source of heat is different: whereas the hot dry air can directly desorb the TCF, in case of the warm fluid, the transfer of the heat to the TCF takes place by an integrated heat exchanger to desorb the TCF by cold air from the environment in periods when the air is dry enough. As a result in both cases, warm concentrated TCF is fed in the hybrid network. The systems are also differing depending on the quality of the heat source. In case of required energy rejection (like in a cooling tower), warm/humid exhaust air from the regeneration process is just rejected to the environment, while an air to air heat exchanger can also increase the intensity of heat recovery.

The network allows for transporting the TCF to the consumers. For the three different processes described above slightly different equipment is required. The simplest equipment is required for drying. This process just requires an absorber that makes contact between the air to be dried and the TCF so that the TCF can remove the humidity from the air. For providing heat for space heating and industrial processes at low to medium level, two different operation modes are possible. First, for using sensible heat, a heat exchanger only takes out the heat from the network. A second mode uses concentrated TCF to operate an open absorption process that either lifts low-temperature heat from the thermal network or from other local heat sources. The condensation heat in the absorber is used for space heating. Greenhouses or humid-air solar collectors can be used as well as local heat sources to produce humid air that transports heat energy from the environment into the building. The third process supported by the network is cooling. For this purpose, an absorber dehumidifies the air so that evaporation cold can be delivered. For space cooling, this cold is generated in the exhaust air stream and transported by a heat exchanger to the supply air so that the evaporation humidity is going outside and only the cold is transferred to the building's spaces.

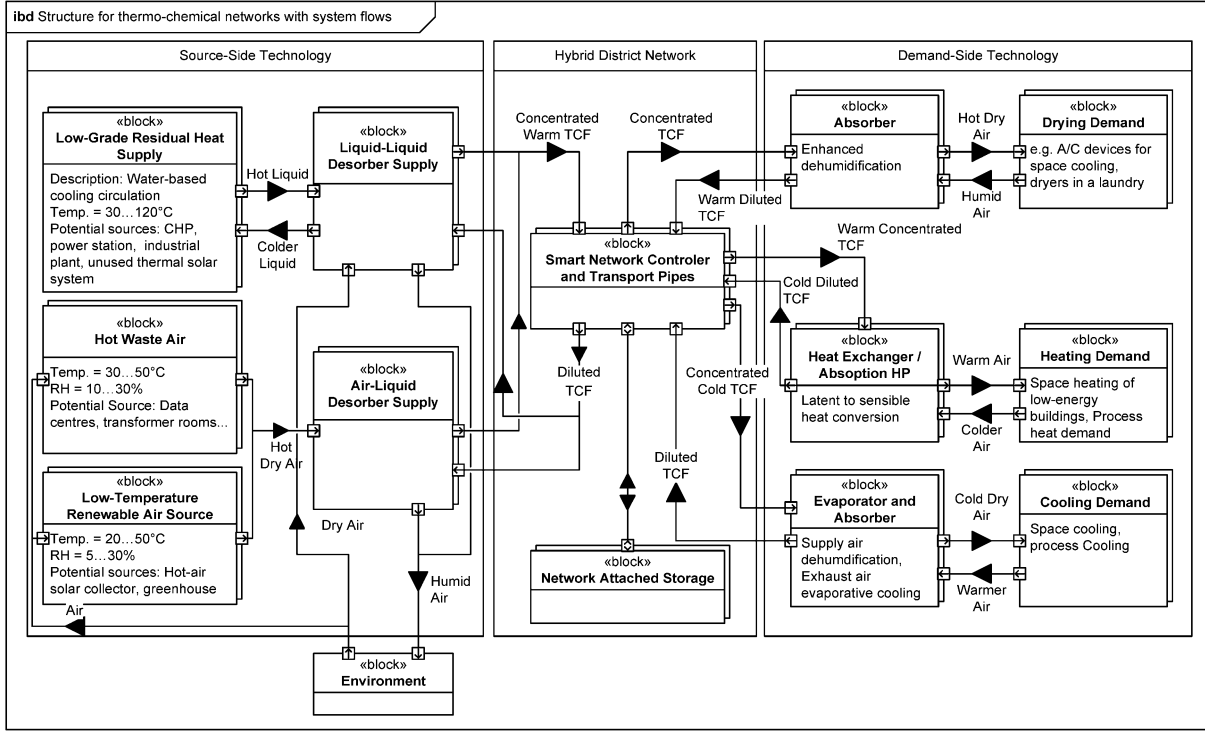

Figure 5: Components of the hybrid thermo-chemical network.

5 Operation examples

To illustrate the operation of the hybrid network, this section presents four application cases corresponding to the key features. These cases describe a simple operation mode of the network to illustrate the potential of the technology. The first case realizes the use case “Capture Low-Temperature Heat” and describes the exploitation of a residual heat source from an industry's cooling circuit. The second case uses the captured thermo-chemical potential for a drying process in an industrial laundry to significantly improve its efficiency. The third case applies the technology for space heating and the fourth case for cooling. The TCF in all cases is $MgCl_2$.

5.1 Exploiting low-temperature residual heat for TCF recovery

The residual heat utilization example, shown at the top of Figure 7, starts from industrial residual heat at $65\text{ }^\circ\text{C}$ with a power of 250 kW . Hot water from a cooling circuit of an industrial system flows through a combined heat exchanger and desorber. This device transfers the heat from the closed cooling circuit to the TCF in a drip chamber that at the same time allows for contact between TCF and air. For instance, a fleece-coated pipe could be used within this device that is charged in counter flow. The main purpose is to desorb the TCF to prepare a concentrated solution. The major part of the residual heat power $P_{residual}$ minus sensible transfer P_{sens} and losses P_{loss} serves to evaporate water from the TCF

$$P_{latent} = P_{residual} - P_{sens} - P_{loss} . \quad (1)$$

A sensible heat transfer P_{sens} of approx. 12 kW warms up the TCF, which is shown later. Losses P_{loss} of 40 kW in the air exchange are expected. Thus, P_{latent} amounts to 198 kW , which means that finally 79% of the residual heat are captured as thermo-chemical potential,

which equal a COP of 0.79. This number corresponds very well with experimental data shown later in Section 6.1.2.

This regeneration process, which takes place in a desorber, such as shown in Figure 2 left, concentrates the TCF MgCl_2 from 17% to 31% according to the equilibrium relative humidity shown in Figure 6. This is possible as the relative humidity of the incoming air is reduced to 5% relative humidity at the inlet by the residual heat of 60°C. The outgoing air from the desorption process at approximately 30°C and 84% goes to a sensible heat recovery (pre-heating the supply air) and then to the outside. This heat recovery feeds the desorption process with air of 25°C and a humidity of 31%.

This change in temperature and humidity equals to a constant desorbed water mass of 6.3 g per kg air. This is calculated based on the relative humidity and saturation mass x_{sat} dependent on the temperature θ in °C according to [44] as following:

$$x_{sat} = 288.68 \left(1.098 + \frac{\theta}{100} \right)^{8.02} \frac{6.42}{1000}. \quad (2)$$

Furthermore, the water flow in the cooling circuit $m'_{cooling\ circuit}$ is defined by

$$m'_{cooling\ circuit} = \frac{P_{residual}}{c_{water}}, \quad (3)$$

with the heat capacity of water c_{water} of 4.2 kJ/kgK. The result is a mass flow of 1.98 kg/s. For the TCF, the mass flow m'_{des} depends on the evaporation process determined by the enthalpy of the water-vapor transition specific for the chosen TCF and the operation conditions $h_{des, water-vapor}$:

$$m'_{des} = \frac{P_{latent}}{h_{des, water-vapor}}. \quad (4)$$

In case of diluted MgCl_2 with concentration 17% being concentrated to 31%, $h_{des, water-vapor}$ is 1040kJ/kg. The result for the power transfer is a TCF mass flow of diluted TCF $m'_{des, dil}$ of 0.19 kg/s. The temperature T_{ret} of this diluted return flow, which is in average assumed to be 30°C, combined with the heat capacity of the TCF c_{des} of 2.1 kJ/kgK determines the required sensible power P_{sens} to warm up the TCF

$$P_{sens} = m'_{des} c_{des} (T_{waste} - T_{ret}). \quad (5)$$

For a residual heat temperature $T_{residual}$ of 60°C, the sensible heat transfer P_{sens} amounts to 12 kW.

The difference between the water flow of 1.98 kg/s and the TCF flow of 0.19 kg/s at maximum in this use case shows a major advantage of the technology: pipe diameter and pump power can be reduced drastically. This leads to less construction effort, less costs and less auxiliary energy consumption.

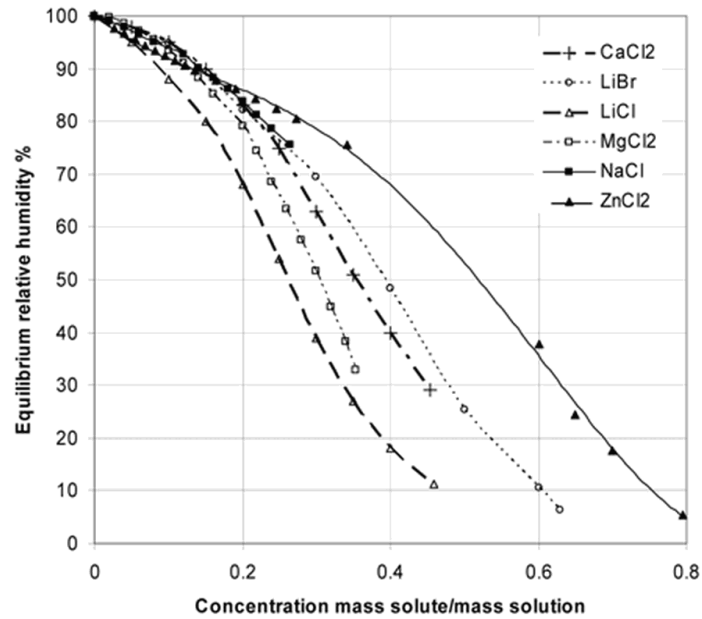

Figure 6: Equilibrium relative humidities (ERH) according to Davies and Knowles [45].

5.2 Drying application

The second case, shown in the diagram at the bottom of Figure 7, describes a possibility of using the thermo-chemical potential for industrial drying. The upper part of the diagram describes the novel technology; the lower part shows a conventional gas-fired process. The novel process takes concentrated TCF from the network. In a drip chamber, this TCF absorbs the humidity, e.g., from the waste air of industrial laundry driers. This process starts at 49°C and 83% humidity and ends at 60°C and 45% humidity with an absorption mass of water $\Delta x = 4.78$ g/kg according to Equation 2. This absorption releases heat:

$$\Delta T = \frac{\Delta x \cdot m'_{air} \cdot h_{water-vapor}}{c_{des} m'_{des} + c_{air} m'_{air}} \quad (6)$$

The temperature lift caused by absorption is 11°C for the described conditions if the mass flows are coordinated well. However, the main benefit from the process is the large decrease of relative humidity in the air. The process runs in air recirculation.

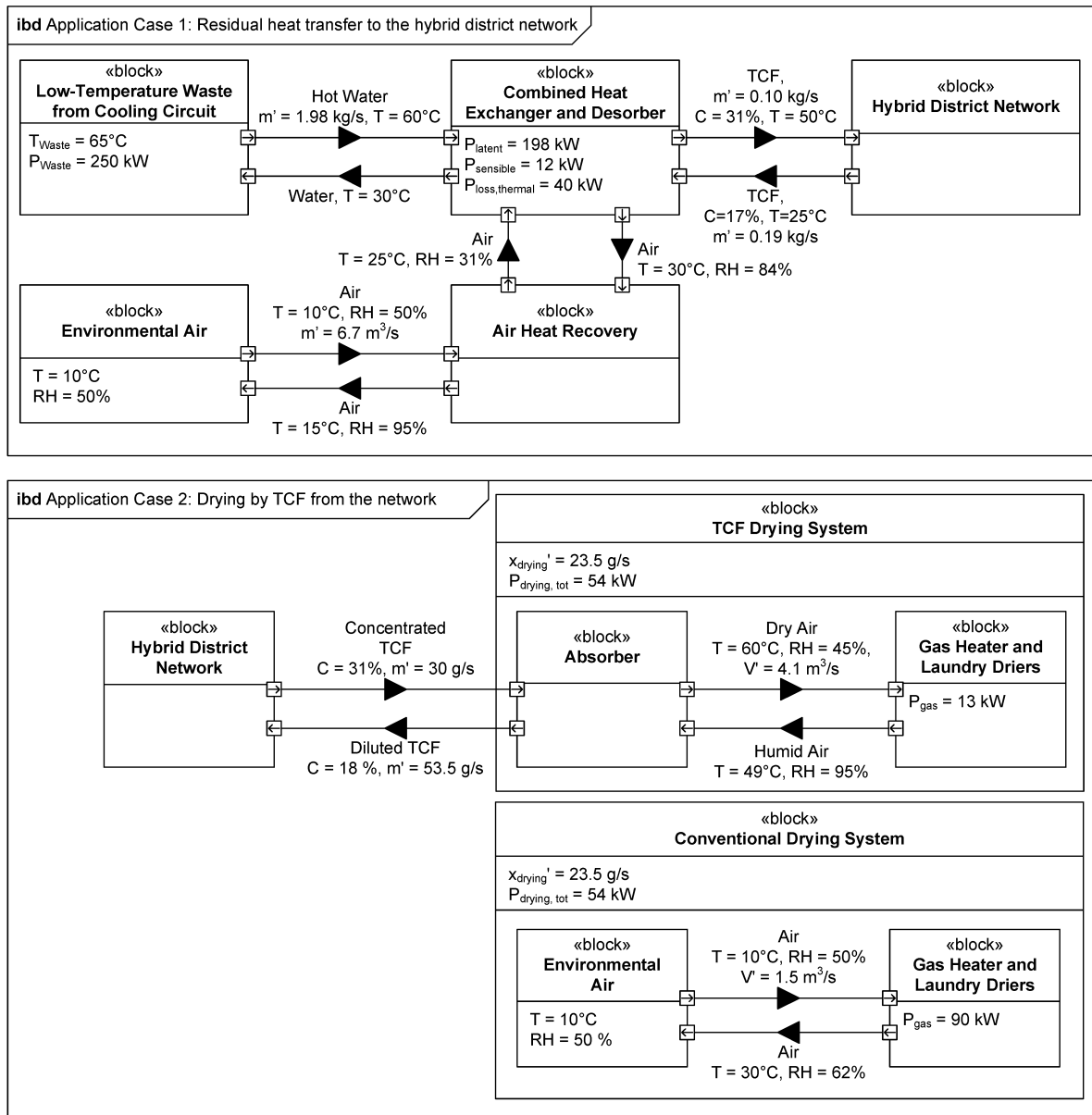

Figure 7, Top: Operation example for capturing residual heat from an industrial process; Bottom: Use of thermo-chemical potential for industrial laundry drying in contrast to the conventional process.

Both systems, the conventional one and the thermo-chemical one have been configured for a drying performance of 54kW. In the thermo-chemical system, this requires a mass flow of air m'_{air} of $4.1\text{ m}^3/s$ for absorption process described before according to Equation 2. The volume flow of the TCF depends on the humidity to be absorbed x_{drying} and the ability of the TCF to absorb water, which is described in Figure 6. The drying performance of 54 kW requires an absorption rate x_{drying}' of 23.5 g/s. Dependent on the relative humidity under the described conditions, the TCF is diluted from 31% to 18% according to Figure 6. This means 1 g concentrated TCF takes up 0.78 g water; thus, in ingoing flow of the TCF of 30 g/s is required leading to an outgoing flow of 53.5 g/s.

Using the thermo-chemical system, the conventional gas heaters only need to warm-up the system and the TCF and to compensate for thermal losses; this auxiliary power P_{gas} of estimated to amount to 13 kW. A conventional system only using gas and outdoor air for drying, which is usual applied because of the need of oxygen for the gas burners, consumes a

gas power P_{gas} of 90 kW to achieve the same drying performance at a lower air mass flow of 1.5 m³/s air.

The thermo-chemical residual heat process and the gas-driven conventional process use nearly the same total power of 85 kW (13 kW gas power plus 54 kW “TCF power” at a capturing rate of 79% of residual heat) respectively 90 kW (gas power). However, there is a huge difference in the quality of energy. The thermo-chemical process mainly runs with a residual heat source of 65°C whereas the conventional process only uses primary energy in the form of gas. Considering this difference in energy quality, the primary energy consumption for the drying process, which is the gas consumption, is reduced by more than 85% to 0.15 kWh instead of 1.06 kWh gas to extract one kilogram of water.

5.3 Heating application

The chief application of district energy networks is space heating. The proposed technology provides this service by lifting thermal energy from lower temperature reservoirs by absorption processes for air heating of indoor spaces at 30 °C. Figure 8 shows a schematic example using the proposed technology for heating. The technology particularly focuses on low-energy buildings that require a limited heating energy supply due to the high quality of their building envelope. In this case, magnesium chloride will also serve as a TCF. Sources of low-temperature heat from local RES are ground heat, conventional solar collectors, humid-air solar collectors or (urban roof/façade) greenhouses and residual heat from air exchange (coming from untapped building internal sources). Together with the energy potential from TCF, these are the main energy sources. Therefore, the system does not consume any primary energy, if the auxiliary electricity (for pumping/ventilation) is generated by RES (e.g. photovoltaics).

The example case in Figure 8 describes a small detached building in an area of low heat demand. Such areas usually cannot be supplied by district energy technology due to the poor economics associated with an insufficient density of users and heat demand. The process gets its heat energy from a low-temperature heat source that mainly evaporates water around 20 °C. The absorber forces condensation of the humidity, which releases the heat energy and lifts the temperature to about 30 °C at 35 % RH, which equals a RH of about 65% at 20 °C. This process provides 10.8 kW sensible heating power to the building and leads to ideal conditions for an air heating for low-energy buildings. To increase the efficiency, the example uses a heat exchanger that supplies the heat source with pre-warmed air. The low volume flow of under 50 g/s TCF going through the absorber allows a network based on thin pipes. These pipes do need insulation as no thermal losses occur.

An additional service of the network is an energy efficient and hygienic humidity control of the supply air by the TCF providing conditions that remain in the comfort zone. This has a specific advantage, particularly as buildings with very low energy consumption are lacking sufficient humidity control due to the advanced heat recovery and air exchange system.

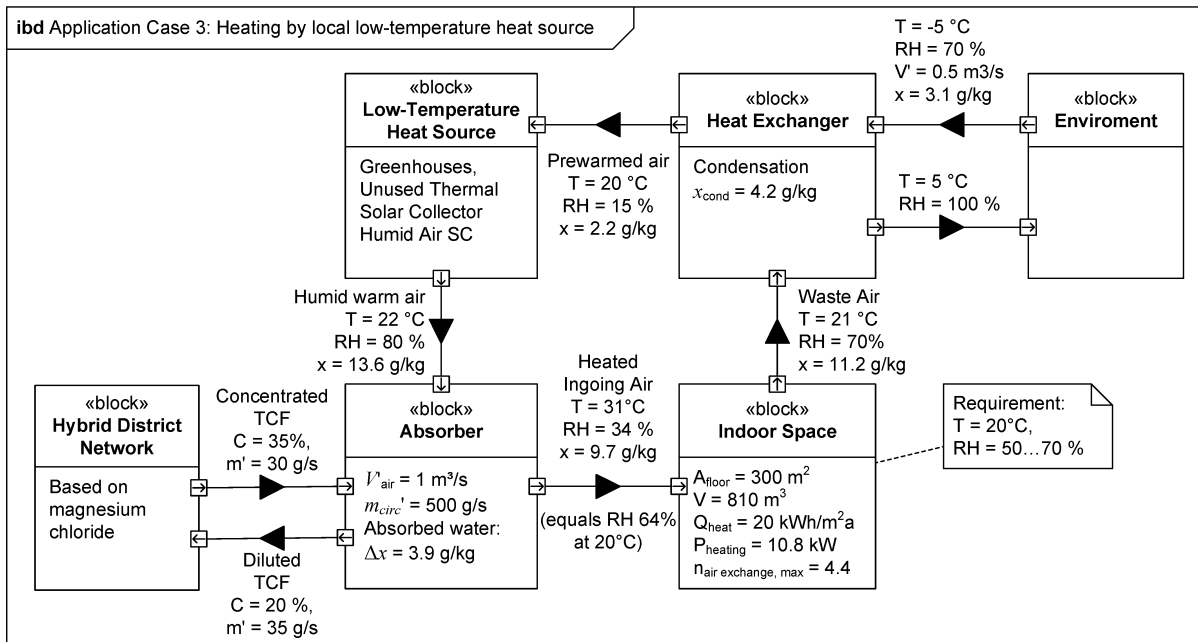

Figure 8: Principle of thermo-chemical technology for space heating.

5.4 Cooling application

For future energy supply networks in the built environment, cooling is an increasingly essential service. Cooling networks are becoming internationally well established, particularly in hot/humid areas. However, there are similar problems as in case of district heating networks that can be solved by thermo-chemical networks.

Two cases of cooling are established that are supplied by a thermo-chemical network: (1) dehumidification combined with cold transfer to the ingoing air and (2) additional evaporative cooling as cold source.

In the first case, a cold source is already available. The thermo-chemical system serves for the dehumidification of ingoing air and for the transfer of cold. Dehumidification is an essential process of cooling that usually causes significant energy consumption in conventional compression cooling as the air is cooled down to the dew point and mechanical energy forces the phase change from vapour to water. Depending on outside ambient temperature and humidity, the dehumidification part of cooling can range up to 80% of the energy demand in the entire cooling process. In the exemplary system in Figure 9, the Absorber uses a TCF to provide these functions as cold TCF cools down the air and at the same time absorbs humidity, so that air enters the building at ideal conditions for human comfort of 20°C and 32% RH, which equals 28% RH at 22°C . Given a temperature of the outgoing air of 25°C , a sensible cooling power of 7.5 kW is provided in case of the volume flow of $2 \text{ m}^3/\text{s}$. For this purpose, a medium concentrated stream of TCF at $C = 15\%$ and a mass flow of $m' = 65 \text{ g/s}$ is required. The first cooling case can utilise cold from ground heat exchangers or provided by a heat pump. In the second case, a water evaporation provides cooling. For this purpose, water is evaporated in the exhaust air leading to a temperature of 17°C at 94% RH. A heat

exchanger transfers only the cold to the TCF, which finally allows heat removal from the ingoing air.

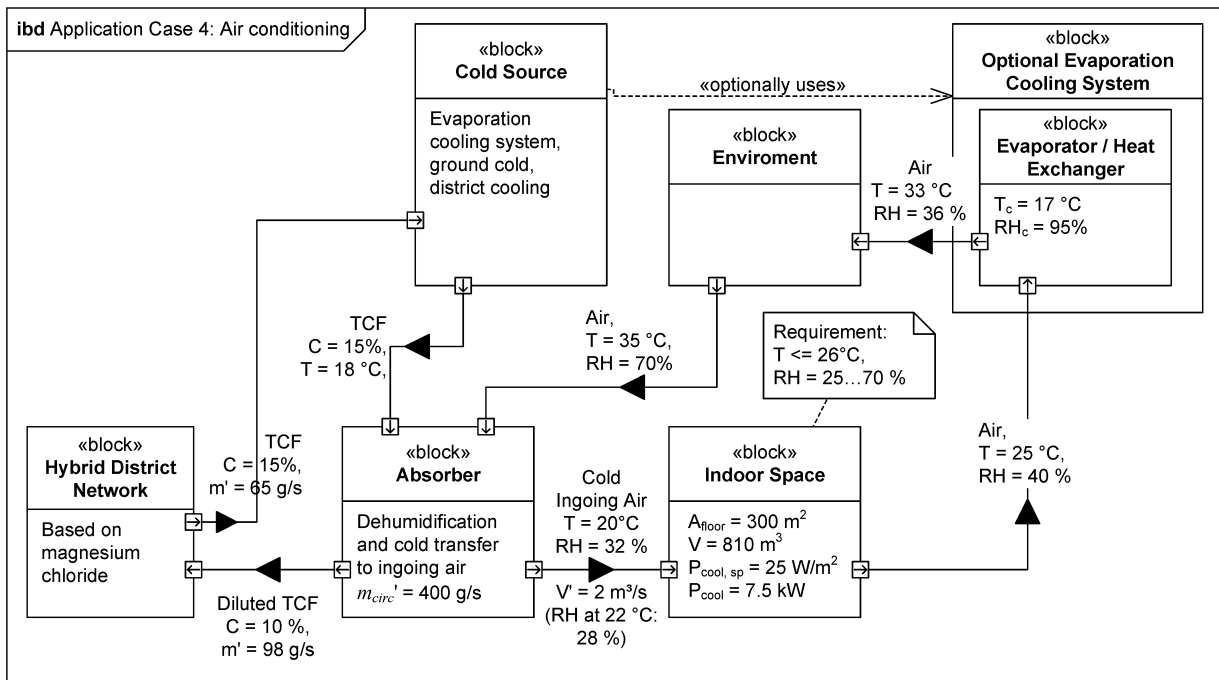

Figure 9: Principle of thermo-chemical technology for space cooling.

6 Realization of hybrid district energy networks

6.1 Ongoing component research

6.1.1 Building Prototype at Technische Universität Berlin (Heating and Cooling)

An experimental building prototype includes a Watery absorber system (Figures 10 and 11). The system consist of two elements: (1) a supply air device, providing air heating and humidification in heating mode and air cooling and de-humidification in cooling mode as well as (2) an exhaust air device, providing latent/sensible heat uptake/recovery during heating mode and exhaust air evaporative cooling during summer mode. The building prototype is attached to a greenhouse as humid solar air collector to test the absorber (Figure 12).

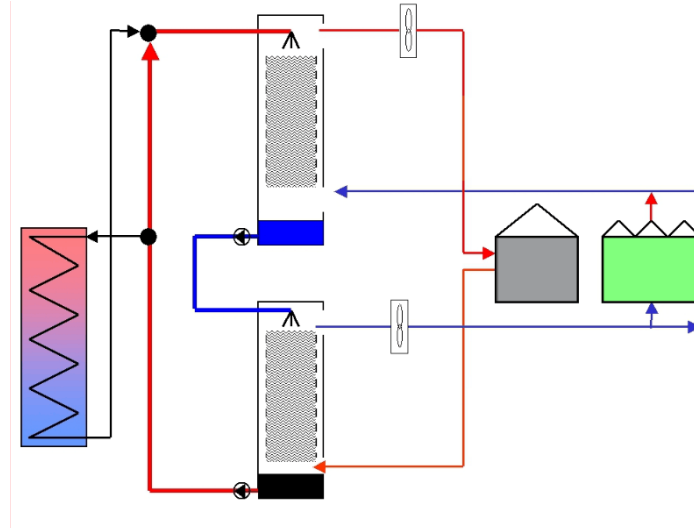

Figure 10: Scheme of the building prototype at Technische Universität Berlin.

During **heating mode**, heat from exhaust air and from a surrounding facade/roof greenhouse can be transferred through air into the building for direct heating purposes. Furthermore, heat can be withdrawn through the TCF into a thermal storage for heat accumulation during periods of high occupancy or peak energy usage in the building or during from the greenhouse during periods of sunshine. While humidity take-up from the building can balance with humidity supply, the TCF needs regeneration under the mode of high performance humidity uptake like the existing greenhouse (that can also be replaced by other dominant humidity sources like in kitchen, sport facilities, swimming pools etc.). The prototype provides a thermal solar collector and an electric device as model low energy source for desiccant regeneration, as it is not connected to a real desiccant network.



Figure 11: Watergy absorber prototype.

In **cooling mode**, heat from supply air is forwarded to the thermal storage that also serves as a reservoir of cool accumulated during night operation. Water absorbed from air humidity is stored in the desiccant. Heat needed for desiccant regeneration is taken from the daytime operation, but the thermal mass in the storage in most cases has to be further heated for sufficient regeneration. In this case, again the desiccant network connection is simulated by the solar thermal device or by the electric heater. It is easier to imagine a standalone application without network for the cooling mode, as usually sufficient low temperature heat can be provided from the direct neighbourhood. Anyway, a connection to a solar thermal collector, e.g. placed on a neighboured roof providing heat for regeneration could be more easily established by a small scale desiccant network rather than a thermal connection.

Further experimental device at TU Berlin is a laboratory version of the Watergy absorber including a heat pump that may be used as an additional element to provide a full heat supply of the building and sufficient cool supply for any hot/humid environment. Due to the high salt content, the return flow of the TCF can be cooled down by the heat pump to around -25° during periods of high heat demand without freezing. In this way, heat from a high storage temperature range can be exploited, even at lowest supply temperatures. The return flow can be heated up again within pipes of the network in the ground, which then also serve for energy uptake from the environment.



Figure 12: Greenhouse attached to a building for testing the Watergy absorber.

6.1.2 Prototype for drying at Botanical Garden Berlin

The prototype shown in Figure 14 is used as an experimental device and demonstrator for all kinds of air/material drying. In the specific case, humid air from a tropical greenhouse (Figure 13) is de-humidified. The latent heat is re-transferred to sensible heat. In this way, dry air with increased temperature is returned to the greenhouse. The alternative technology would be air exchange with heat recovery from exhaust to supply air through a heat exchanger. This technology would always provide a lower temperature compared to the greenhouse temperature, while the desiccant system provides a higher temperature and directly supports the heating system. The experiments of this prototype relate to optimum configuration of air/desiccant volume flow in the absorption and desorption process. The low-temperature heat source of the prototype is simulated by an electric heater. As next step in a scale-up, this heat source is planned to be replaced by the return flow of a closely located district heating network (operating at around 40°C in average) and may show that a regenerator supplying a small neighbourhood desiccant network can already improve a large district heating network by allowing for a higher temperature difference or similar temperature difference at total lower temperatures.

A regeneration experiment proves this scenario. The TCF has been warmed up by an auxiliary heat source and the humidity transfer from TCF to air has been measured. The warming-up process took place via a heat transfer fluid with temperatures T_{HTF} from 29.8 to 40.6 °C, which simulated the residual heat source. Outdoor air between 2.5 and 14.8 °C and humidity between 3.6 and 5.4 g water per kg air as well as heat between 26.1 and 40.6 °C supply the process. The results shown in Figure 15 demonstrate that approximately 60 to 70% of the heat serves the evaporation process (COP of 0.6 to 0.7). We expect the COP to increase to approximately 80% with further optimization and scale-up of the desorber.



Figure 13: Greenhouse of the Botanical Garden Berlin that requires air drying and latent heat recovery.



Figure 14: Prototypical device for air drying recirculation in the greenhouse of the Botanical Garden Berlin.

Date	T _{in} in °C	x _{in} in g/kg	T _{HTF} in °C	COP
19.02.2016	7.0	3.6	26.1	0.570
17.02.2016	5.8	4.2	38.0	0.576
31.03.2016	11.5	5.4	22.5	0.577
15.01.2016	2.5	4.3	40.6	0.583
09.03.2016	9.3	4.5	30.0	0.590
31.03.2016	10.4	5.2	32.2	0.621
10.02.2016	8.8	4.5	38.7	0.621
05.02.2016	6.8	4.8	38.9	0.622
03.02.2016	9.2	3.8	40.6	0.693
08.04.2016	14.8	5.2	29.8	0.741

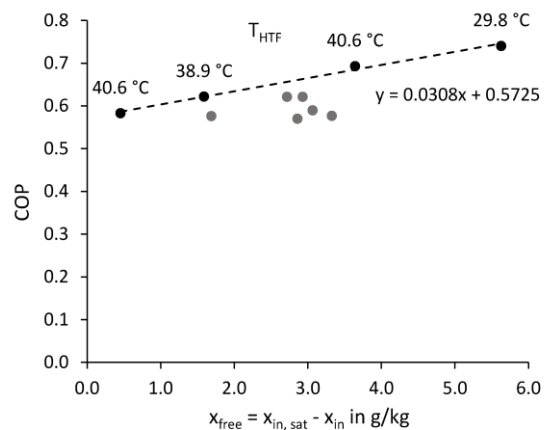

Figure 15: Measurements of the regeneration process at the prototype Botanical Garden Berlin.

6.1.3 Adlershof as first prototype of desiccant network

A project Energy Network Berlin Adlershof, funded by the German Federal Ministry for Economic Affairs and Energy, currently in planning phase, will include a first small scale

thermo-chemical network, consisting of a regenerator using excess heat from an industrial process and providing desiccant concentrate for a neighbored industrial laundry dryer as well as for a building latent heat recovery process.

7 Future research and application

The network approach described in this paper is up to now mainly a theoretical projection from laboratory work and local prototypes described in Section 6. However, there is future research to tackle the realisation of a thermo-chemical district network. In June 2016, the EU H2020 collaborative research project “H-DisNet - Intelligent Hybrid Thermo-Chemical District Networks” will start. The project will include laboratory work to develop and optimize the thermo-chemical components for network application, demonstration at three location in the EU to illustrate the application of the technology as well as modelling, simulation and the examination of case studies.

In terms of application, two different cases are of major interest and will be examined in the research project in detail for their technological and economic feasibility. The first case is the application in symbiosis with existing thermal district heating networks. The main advantage in this case is the possible reduction of return flow temperatures in a first step and the reduction of all fluid temperature levels in a second step. By this measure, heat losses in networks will be reduced significantly. The best prerequisite for an economical installation of the new technology is that underground shafts exists in that pipes for the new technology can be integrated.

The second application case is the construction of new pure thermo-chemical networks in areas with low heat demands density. The conventional district heating technology cannot serve these areas well due to economic reasons and the predominance of heat losses in such a situation. Small plastic pipes and low to no temperature thermo-chemical networks provide a large benefit in this situation since they reduce thermal losses, which are one main factor for low-density networks, and installation costs, which are the second main factor, dramatically.

8 Conclusions

The use of mixed thermo-chemical networks is very promising for the future improvement of residual heat or renewables at low-temperature. This allows to increase energy efficiency and to reduce primary energy consumption and greenhouse gas emissions. Further benefits are the reduction of water usage or even closed water loops. The exemplary drying process showed a reduction of 85% of the primary energy consumption. Cooling and heating perform in a similar way. Therefore, thermo-chemical networks tap a high potential to reduce primary energy consumption.

The benefits of thermo-chemical technology compared to conventional thermal technology can be summarised as:

1. **Extension of services:** The thermo-chemical network technology provides a broader range of services compared to a conventional water-based district heating network. Scenarios for space heating and cooling as well as drying have been shown. Such a multi-service network increases the effectiveness of investments for the network infrastructure and thus improves the feasibility of district networks even in areas of low-density demand.
2. **Long-distance transport:** The reduction of losses allows the transport over long distances between supply and demand. It has been shown that economic considerations allow distances of 50 km and more. This is one key advantage for residual heat utilization.
3. **Loss-free storage:** The ability to store the potential loss-free and thus to shift the usage in time, which is provided by the thermo-chemical technology, is furthermore vital. Due to economic reasons the short-term and medium-term time shift between within days and weeks is most interesting. This is a second key advantage for residual heat utilization.
4. **Reduced construction and operation costs:** The thermo-chemical technology only working with the latent heat potential uses smaller pipes made of plastic without insulation. This causes less material and construction costs. Furthermore, reduced pumping power can be expected due to the higher energy density and less fluid transport probably levelling out the little higher viscosity of TCF compared to water.

These abilities of hybrid networks are the key to access residual heat sources as they often occur in industrial areas located distant to typical consumers such as residential areas and have a time shift during the day. This can also include unused thermal energy from renewable sources, such as solar thermal or geothermal systems, whose temperature level is too low for direct usage or whose potential is not utilized for periods during days or weeks. Therefore, hybrid thermo-chemical district networks provide a technology to significantly increase the efficiency of energy usage for non-renewable as well as renewable sources.

Acknowledgements

The presented research results are based on the preparation for the project H-DisNet funded by a VES grant by KU Leuven, on the project WE4CC funded by EU EIT Climate KIC and on the project Energienetz Berlin-Adlershof funded by the German Federal Ministry for Economic Affairs and Energy in the programme EnEff:Stadt.

References

- [1] Enova (2009): Utnyttelse av spillvarme fra norsk industri - en potensialstudie, <http://www2.enova.no/minas27/publicationdetails.aspx?publicationID=423>, accessed Feb 2015.
- [2] Pehnt M, Bödeker J, Arens M, Idrissova F (2011): Industrial Residual heat – tapping into a neglected efficiency potential, eceee 2001 Summer Study. Energy efficiency first: The foundation of a low-carbon society.
- [3] Walsh C, Thornley P (2013): A comparison of two low grade heat recovery options, Applied Thermal Engineering 53(2), pp. 210-216, <http://dx.doi.org/10.1016/j.applthermaleng.2012.04.035>.

- [4] Law R, Harvey A, Reay D (2013): Opportunities for low-grade heat recovery in the UK food processing industry, *Applied Thermal Engineering* 53(2), pp. 188-196, <http://dx.doi.org/10.1016/j.applthermaleng.2012.03.024>.
- [5] Ma Q, Luo L, Wang RZ, Sauce G (2009): A review on transportation of heat energy over long distance: Exploratory development, *Renewable and Sustainable Energy Reviews* 13(6–7), pp. 1532-1540, <http://dx.doi.org/10.1016/j.rser.2008.10.004>.
- [6] Kang Y, Akisawa A, Sambe Y, Kashiwagi T (2000): Absorption heat pump systems for solution transportation at ambient temperature — STA cycle, *Energy* 25(4), pp. 355-370, [http://dx.doi.org/10.1016/S0360-5442\(99\)00070-5](http://dx.doi.org/10.1016/S0360-5442(99)00070-5).
- [7] Lin P, Wang RZ, Xia ZZ, Ma Q (2011): Ammonia–water absorption cycle: a prospective way to transport low-grade heat energy over long distance, *International Journal of Low-Carbon Technologies* 6(2), pp. 125-133.
- [8] Kiani B, Hamamoto Y, Akisawa A, Kashiwagi T (2004): CO₂ mitigating effects by residual heat utilization from industry sector to metropolitan areas, *Energy* 29(12–15), pp. 2061-2075, <http://dx.doi.org/10.1016/j.energy.2004.03.012>.
- [9] Kiani B, Akisawa A, Kashiwagi T (2008): Thermodynamic analysis of load-leveling hyper energy converting and utilization system, *Energy* 33(3), pp. 400-409, <http://dx.doi.org/10.1016/j.energy.2007.10.005>.
- [10] Ammar Y, Chen Y, Joyce S, Wang Y (2013): Evaluation of low grade heat transport in the process industry using absorption processes, *Applied Thermal Engineering* 53(2), pp. 217-225, <http://dx.doi.org/10.1016/j.applthermaleng.2012.04.056>.
- [11] N'Tsoukpoe KE, Liu H, Le Pierrès N, Luo L (2009): A review on long-term sorption solar energy storage, *Renewable and Sustainable Energy Reviews* 13(9), pp. 2385-2396, <http://dx.doi.org/10.1016/j.rser.2009.05.008>.
- [12] Yan T, Wang RZ, Li TX, Wang LW (2015): A review of promising candidate reactions for chemical heat storage, *Renewable and Sustainable Energy Reviews* 43(), pp. 13-31, <http://dx.doi.org/10.1016/j.rser.2014.11.015>.
- [13] Kalaiselvam S, Parameshwaran R (2014): Chapter 6 - Thermochemical Energy Storage, in: *Thermal Energy Storage Technologies for Sustainability*, Academic Press, pp. 127-144, <http://dx.doi.org/10.1016/B978-0-12-417291-3.00006-2>.
- [14] Jänchen J, Ackermann D, Stach H, Brösicke W (2004): Studies of the water adsorption on Zeolites and modified mesoporous materials for seasonal storage of solar heat, *Solar Energy* 76(1–3), pp. 339-344, <http://dx.doi.org/10.1016/j.solener.2003.07.036>.
- [15] Dicaire D, Tezel FH (2011): Regeneration and efficiency characterization of hybrid adsorbent for thermal energy storage of excess and solar heat, *Renewable Energy* 36(3), pp. 986-992, <http://dx.doi.org/10.1016/j.renene.2010.08.031>.
- [16] Hauer A (2007): Evaluation of adsorbent materials for heat pump and thermal energy storage applications in open systems, *Springer US* 13(3-4), pp. 399-405-, <http://dx.doi.org/10.1007/s10450-007-9054-0>.
- [17] Hauer A (2007): Sorption Theory for Thermal Energy Storage, in: *Thermal Energy Storage for Sustainable Energy Consumption: Fundamentals, Case Studies and Design*, Springer Netherlands, pp. 393-408, http://dx.doi.org/10.1007/978-1-4020-5290-3_24.
- [18] Hauer A (2007): Adsorption Systems for TES—Design and Demonstration Projects, in: *Thermal Energy Storage for Sustainable Energy Consumption: Fundamentals, Case Studies and Design*, Springer Netherlands, pp. 409-427, http://dx.doi.org/10.1007/978-1-4020-5290-3_25.
- [19] Hauer A, Fischer S, Heinemann U, Schreiner M, Schoelkopf W (1999): Thermochemical energy storage and heat transformation of district heat for balancing of, *Bayerisches Zentrum fuer Angewandte Energieforschung e.V., Wuerzburg (Germany)*.
- [20] Buchholz M, Buchholz R, Geyer P, Schmidt M (2009): Watery – ein Feuchtluft-Solarkollektorsystem mit saisonaler Energiespeicherung zur Gebäudeheizung, *Bauhaus Solar*, 11.-12.11.2009.
- [21] Buchholz M, Buchholz R, Hanßke A, Paitazoglou C, Ziegler F (2012): Nutzung von Sole als Energieträger und Speichermedium in einem urbanen Entwicklungsgebiet, *3rd International Conference, Low Temperature and Waste Heat Use in Energy Supply Systems*.

- [22] Vanhoudt et al. D (2014): E-HUB - D3.2 Report on a combination of thermal storage techniques and components, www.e-hub.org/pdf/D3.2_Thermal_storage_techniques_components.pdf, accessed Apr 2016.
- [23] Zondag H, Kikkert B, Smeding S, Boer Rd (2013): Prototype thermochemical heat storage with open reactor system, *Applied Energy* 109(), pp. 360-365, <http://dx.doi.org/10.1016/j.apenergy.2013.01.082>.
- [24] Posern K, Kaps Ch (2010): Calorimetric studies of thermochemical heat storage materials based on mixtures of MgSO₄ and MgCl₂, *Thermochimica Acta* 502(1-2), pp. 73-76, <http://dx.doi.org/10.1016/j.tca.2010.02.009>.
- [25] Michel B, Mazet N, Neveu P (2014): Experimental investigation of an innovative thermochemical process operating with a hydrate salt and moist air for thermal storage of solar energy: Global performance, *Applied Energy* 129(), pp. 177-186, <http://dx.doi.org/10.1016/j.apenergy.2014.04.073>.
- [26] Hauer A, Lävemann EL (2007): Open Absorption Systems for Air Conditioning and Thermal Energy Storage, in: *Thermal Energy Storage for Sustainable Energy Consumption: Fundamentals, Case Studies and Design*, Springer Netherlands, pp. 429-444, http://dx.doi.org/10.1007/978-1-4020-5290-3_26.
- [27] N'Tsoukpoe KE, Schmidt T, Rammelberg HU, Watts BA (2014): A systematic multi-step screening of numerous salt hydrates for low temperature thermochemical energy storage, *Applied Energy* 124(), pp. 1-16, <http://dx.doi.org/10.1016/j.apenergy.2014.02.053>.
- [28] Basciotti D, Pol O (2012): A Theoretical Study Of The Impact Of Using Small Scale Thermo Chemical Storage Units In District Heating Networks, IEA SHC Task 42 - Compact Thermal Energy Storage - Systems, https://www.apc.upvg.uni-kassel.biomass.iea-shc.org/data/sites/1/publications/Task42-Theoretical_Study_of_the_Impact_of_Using_Small_Scale_Thermo_Chemical_Storage_Units_in_District_Heating_Networks.pdf.
- [29] Mazet N, Luo L, Stitou D, Berthiaud J (2010): Feasibility of long-distance transport of thermal energy using solid sorption processes, *International Journal of Energy Research* 34(8), pp. 673-687, <http://dx.doi.org/10.1002/er.1578>.
- [30] Storch, G., Hauer, A.: Cost-effectiveness of a heat energy distribution system based on mobile storage units: two case studies. In: *Proceedings of the ECOSTOCK conference*, Stockton, 2006.
- [31] Wang W, Hu Y, Yan J, Nyström J (2010): Combined heat and power plant integrated with mobilized thermal energy storage (M-TES) system, *SP Higher Education Press* 4(4), pp. 469-474, <http://dx.doi.org/10.1007/s11708-010-0123-9>.
- [32] Guo S, Li H, Zhao J, Li X (2013): Numerical simulation study on optimizing charging process of the direct contact mobilized thermal energy storage, *Applied Energy* 112(), pp. 1416-1423, <http://dx.doi.org/10.1016/j.apenergy.2013.01.020>.
- [33] Wang W, Li H, Guo S, He S (2015): Numerical simulation study on discharging process of the direct-contact phase change energy storage system, *Applied Energy* 150(), pp. 61-68, <http://dx.doi.org/10.1016/j.apenergy.2015.03.108>.
- [34] Guo S, Zhao J, Wang W, Yan J (2016): Numerical study of the improvement of an indirect contact mobilized thermal energy storage container, *Applied Energy* 161(), pp. 476-486, <http://dx.doi.org/10.1016/j.apenergy.2015.10.032>.
- [35] Nomura T, Okinaka N, Akiyama T (2010): Residual heat transportation system, using phase change material (PCM) from steelworks to chemical plant, *Resources, Conservation and Recycling* 54(11), pp. 1000-1006, <http://dx.doi.org/10.1016/j.resconrec.2010.02.007>.
- [36] Bichowsky FR, Kelley GA(1935): Concentrated solutions in air-conditioning, *Industrial & Engineering Chemistry* 27(8), 879-882.
- [37] Biel B, Röben J (1997): Sorptive Entfeuchtung und Temperaturabsenkung bei der Klimatisierung, Final Report on the BMBF Project 0329151J.
- [38] Buchholz M, Buchholz R, Geyer P, Schmidt M (2010): Watergy - ein Feuchtluft-Solarkollektorsystem mit integriertem Solekreislauf zur Gebäudeheizung, 20. Symposium thermische Solarenergie.
- [39] Geyer P, Nemeth I, Lang W, Wulfhorst G, Roland P (2012): Systems modelling considering qualities and quantities for strategies of sustainable development of a liveable urban district in Nuremberg, *Proceedings of the eg-ice Workshop 2012*, TU München.

- [40] Geyer P (2012): Systems modelling for sustainable building design, *Advanced Engineering Informatics* 26(4), pp. 656-668, <http://dx.doi.org/10.1016/j.aei.2012.04.005>.
- [41] Geyer P, Ritter F (2015): Identifying Thermal Microgrids on the Basis of Spatialized Fuzzy Logic and Metamodelling, *eg-ice Workshop 2015*, Eindhoven.
- [42] Schlüter A, Geyer P, Cisar S (2016): Analysis of Geo-referenced Building Data for the Identification and Evaluation of Thermal Microgrids, *Proceedings of the IEEE, Special Issue Microgrids and Energy Efficient Buildings*, in print.
- [43] Object Management Group (2012): *Systems Modeling Language, Specifications Version 1.3*, <http://www.omg.org/spec/SysML/1.3/>, accessed Apr 2013.
- [44] Willems WM, Schild K, Dinter S, Stricker D (2007): *Formeln und Tabellen Bauphysik*, Vieweg, Wiesbaden.
- [45] Davies PA, Knowles PR (2006): Seawater bitterns as a source of liquid desiccant for use in solar-cooled greenhouses *Desalination* 196, 266-279.
- [46] Frederiksen S, Werner S (2013): *District heating and cooling*, Studentlitteratur, Lund.