

# Peer-to-Peer Control of Microgrids

Hamada Almasalma\*, Jonas Engels\*, Geert Deconinck  
ESAT-ELECTA, KU Leuven, Kasteelpark Arenberg 10, 3001 Leuven, Belgium  
EnergyVille, Thor Park 8300, 3600 Genk, Belgium  
hamada.almasalma@kuleuven.be, jonas.engels@kuleuven.be

\*Equally contributing authors

**Abstract**—In this paper, the motivation to develop microgrids as an effective solution for the control of distribution networks with high level penetration of Distributed Energy Resources (DERs) is discussed. As many different control methods for microgrids can be found in literature, this paper proposes a classification from highly centralized to distributed peer-to-peer control architectures. A peer-to-peer control paradigm is proposed as a way to control the distribution network with a high penetration of distributed energy resources. Different control algorithms suited for the proposed peer-to-peer control strategy are discussed.

**Index Terms**—Microgrid Control, Distributed Energy Resources, Peer-to-Peer Control, Distributed Coordination and Control.

## I. INTRODUCTION

Growing concerns about energy sustainability, security of supply and an increasing penetration of renewable energy and other distributed energy resources (DERs), such as storage systems and electrical vehicles, are impacting the operation and the architecture of the electricity system. While currently placing a burden on the distribution grid, it is generally agreed that DERs could also be used for active grid control, thereby contributing to a stable and secure grid. To accomplish this, new control systems have to be designed that are able to fully harness the potential of the installed DERs [1]. This active monitoring and control of the distribution grid is commonly referred to as an essential part of the *smart grid*, which is regarded to be key in the future integration of electricity consumers, generators and those that do both (prosumers).

Current distribution networks are not designed to accommodate a large amount of DERs. A large penetration of DERs may create problems to maintain the quality of supply to all customers connected to the distribution network. Besides, the intermittent nature of DERs can create issues with the second-by-second balance of demand and supply. However, by coordinating the DERs, these issues could be resolved without the need for additional investments in grid infrastructure [2].

In the literature [3], the idea of a microgrid is an often mentioned alternative to controlling the whole distribution grid with a large amount of DERs. The main idea is that, when there are many DERs in a wide network, it can be

very complex and difficult to control. Thus, a potential way to manage this complexity is by breaking down the entire grid into a smaller microgrids, containing only a limited amount of DERs. This paper elaborates this idea and proposes an operational control paradigm for the future distribution grid, based on the concept of microgrids.

When considering such a microgrid and the coordination of multiple microgrids, different control methods can be found in literature [4]. This paper proposes a taxonomy of these control methods, from fully centralized to completely decentralized. A highly decentralized control method, the peer-to-peer control architecture, is further elaborated in this paper, as it is a promising way for future control of the distribution grid. Since the DERs are typically highly distributed, operated by many different owners and with different objectives, it is desirable that the microgrid control system operates in a highly distributed way as well. Besides, a robust control system is needed that does not depend on a single point of failure, as most of the more centralized control methods do.

The rest of the paper is organized as follows: section II introduces the most prominent issues with regard to the integration of DERs in the electrical grid, together with an elaboration of the microgrid concept that would be able to overcome these issues. Section III proposes a categorization for the different architectures of microgrid control. Section IV then proposes a new control paradigm for the distribution grid, based on the microgrid concept and the previously identified peer-to-peer architecture. Finally, the paper is concluded in section V.

## II. ISSUES WITH THE INTEGRATION OF DERs IN THE ELECTRICAL GRID

This section summarizes the most prominent issues with regard to the integration of DERs in the current electrical grid. Both voltage issues and frequency or stability issues are discussed. Other type of issues, such as harmonics, security issues and power fluctuations are not discussed here. The microgrid concept is presented as a possible solution that is able to overcome these issues.

### A. Voltage Issues

A large penetration of DERs may create problems to maintain the voltage quality of all customers connected to the same part of the distribution network. Up till now, voltage

This work is partially supported by H2020-LCE-2014-3 Peer to Peer Smart Energy Distribution Networks (P2PSmartTest) project (European Commission).

quality in the distribution grid is achieved based on the layout of grid infrastructure that is capable of operating within limits even in worst case scenarios, with the assumption of unidirectional power flows. The planning of the infrastructure is quite straightforward: minimum and maximum load conditions are considered and minimum and maximum voltages in the grid are examined. The network is dimensioned in such a way that the minimum voltage is near the lower limit of the allowed voltage range and the maximum voltage is near the upper limit of the allowed voltage range. When connecting significant amounts of distributed generation to the network, the assumption of unidirectional power flows is not always valid any more and the voltage profile of the network can be quite different than in the case without any generation. With maximum load conditions, distributed generation increases the voltage level in the network and, hence, enhance the voltage quality in the grid. However, when the load on the network is at a minimum, the generated power of the distributed generation can reverse the power flows in the grid, what could lead to a rise of the voltage profile beyond its allowed limits.

Therefore, the hosting capacity for renewable generation of many traditional distribution networks is limited by the voltage variations that occur between maximum and minimum load conditions. The traditional solution to this problem is to reinforce the local distribution grid by installing more cables. However, generally this is quite expensive, as new infrastructure has to be installed in residential neighborhoods. Another approach is by using the already installed infrastructure in a more optimal way, by coordination of the local generation, on-load tap changers or other equipment used to control voltage in distribution networks. This is the purpose of the smart grid [5].

### B. Frequency and Stability Issues

The consumption and generation in the electricity system has to be balanced on a second-by-second basis. Traditionally, this balance is maintained by flexible generation units that are standby and are able to regulate their generated amount of electricity as required. However, the intermittent and unpredictable nature of new renewable energy sources creates issues with this traditional approach, as these new sources are usually not dispatchable.

Any deviation from the demand and supply balance results in a deviation of the system frequency from its nominal value, while large frequency deviations will affect the system stability. Therefore, the system operators maintain frequency within strict limits by using ancillary services for balancing of the grid, that are able to respond within various time frames [6]. Up till now these balancing services are exclusively organized by the transmission system operator (TSO). However, with the high penetration of DERs, maintaining the supply and demand balance and thus the system frequency within limits becomes more challenging. Spinning reserves or energy storage can address this problem but with a considerable cost. Therefore, power system operators are increasingly seeking new reserves for frequency response from demand flexibility, instead of

supply. As most of the demand is connected to the distribution grid, this means that the distribution system operators (DSOs) will be involved in this process.

### C. Towards a New Control Paradigm for the Distribution Grid

One of the key solutions to overcome the above mentioned challenges of integrating DERs in the distribution grid is the design of a smart grid, containing control systems for the coordination of these DERs, thereby ensuring a reliable, secure and economical operation of the distribution network at all times.

Controlling the distribution network to be able to utilize the emerging diversity of DERs at significant levels of penetration, means that the control system has to be able to manage a wide and dynamic set of resources. Controlling such a complex network is not a trivial task. A potential way to manage this complexity is by breaking the entire grid down into smaller microgrids, containing only a limited amount of DERs. These microgrids should be able to control their local resources as optimal as possible, while being connected to the rest of the grid through a point of common coupling (PCC) [7].

These microgrids can be coordinated on a higher level into a system of multi-microgrids. The main idea is to design the control of the microgrid in such a way that the microgrid is perceived by the main grid as a single element responding to appropriate control signals. There are different possible architectures of operating such a microgrid, for which this paper proposes a classification ranging from fully centralized methods to fully distributed in section III.

A conventional way of controlling such a microgrid, is by a hierarchy of three control levels, each operating on a different timescale and with a different priority: primary, secondary and tertiary [8], [9]. Primary control is focused on keeping the grid stable in all circumstances, thus it needs the largest priority and should act on the smallest time scale. A robust control method is needed, so that in case e.g. the communication network fails, the primary control is still able to maintain stability of the microgrid. Therefore, as little communication as possible is desired. As primary control is often implemented as some kind of proportional controller, a steady state error remains, that shall have to be eliminated with the use of a secondary control method. Secondary control is activated on a slower time scale, e.g. every 15 minutes, and with a lower priority than primary control. Finally, tertiary control is implemented as the slowest level of control, with as purpose the economically optimal operation of the microgrid. Both secondary and tertiary controls usually require at least some kind of communication, as knowledge about the state of the entire system is needed.

These three control levels can be implemented through various organizational architectures of the microgrid. In the following section, this paper proposes a classification for these different architectures.

## III. ARCHITECTURES OF MICROGRID CONTROL

The control of the DERs in a single microgrid can be organised according to many different control architectures.

They can range from fully centralized control where all decisions are made by a single central controller, to completely decentralized controls where all decisions are made by the local DERs. The required communication architecture changes accordingly. In most practical cases, a hybrid architecture exists, where e.g. primary control is implemented locally, and secondary control centrally.

This paper identifies five different approaches, shown in figure 1: (a) centralized control, (b) hierarchical control, (c) distributed control, (d) fully decentralized P2P control and (e) local control.

*A. Centralized Control Architecture*

In an fully centralized design shown in figure 1(a), all available measurements of the considered microgrid are gathered in a central controller that determines the control actions for all units. Reference [10] presents an implementation of a centralized controller based on Wide Area Monitoring and Control system (WAMC) that can be used to implement a centralized secondary and tertiary control. In [11] WAMC has been used to implement a centralized secondary voltage controller.

When looking at a single microgrid, the centralized controller is often referred to as a Microgrid Central Controller (MGCC). The advantage of a centralized control system is that the central system receives all necessary data of the microgrid, and based on all available information the multi-objective controller can achieve globally optimal performance. As there is only one controller, this results in a high controllability of the system. However, this high performance comes at a cost. First of all, the computational burden is heavy, as the optimization is computed based on a large amount of information. Moreover, a centralized controller is a single point of failure and redundancy of the central controller is expensive. The loss of communication with the central controller may cause a shutdown of the overall system. Besides, as all system states and boundary conditions have to be known at the central point, this requires a high quality of communication from all DERs to the central point of control. There is also the concern that the owners of the different DERs are not willing to hand over control of their resources to a third party. Finally, central systems are usually regarded as not being very scalable and system maintenance requires complete shutdown [12]. To overcome these issues, more distributed control architectures are developed, as described in the sections below.

*B. Hierarchical Control Architecture*

A first step towards a more decentralized control architecture is the introduction of a hierarchical system, as shown in figure 1(b). In this case, there exists some kind of aggregation of the local DERs towards the central controller. Typically, the characteristics of the DERs are represented by a few heuristics or parameters that are combined by an aggregator, who is able to offer these aggregated resources to a central optimizer. The central controller is then able to dispatch the necessary resources, through a hierarchical system of aggregators, who

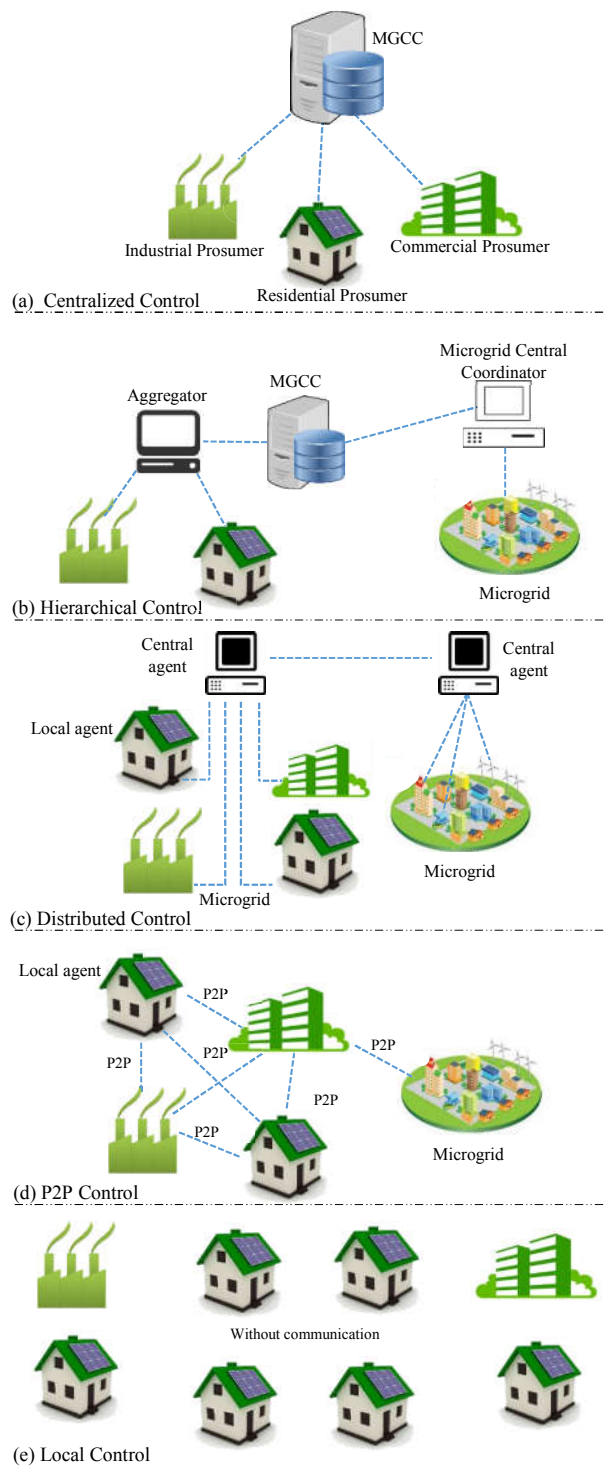

Fig. 1. Architecture of a microgrid control

determine which DERs should be used at which moment. Therefore, these methods are also referred to as *aggregate and dispatch* methods. As the resources are offered to the central optimizer in an aggregated way, there is considerably

less information needed at the central controller, which results in a more scalable system. However, the single point of failure remains, and the points of aggregation might even become new points of failure.

Nowadays, this approach is used for exploiting demand response resources. Examples are the *Intelligator* algorithm [13], or the demand response reserves offered by aggregators to a TSO for e.g. automatic or manual frequency restoration reserves (aFRR or mFRR). The coordination of multiple, centrally controlled microgrids can also be organized in a hierarchical way. In that case, a *central coordinator* coordinates multiple microgrids, each controlled by a local MGCC. The MGCC of a single microgrid tries to reach an optimal operation point using only its local resources. If the internal resources are not sufficient, the MGCC shall ask the microgrid central coordinator for external resources from other microgrids [14].

### C. Distributed Control Architecture

In both architectures described above, the DERs are controlled by a third party. However, since the owners of the DERs impose the operational boundary conditions, one can argue that it might be better to keep the control of the DERs locally. Besides, not all DER owners want to exchange all their information with a third party for privacy reasons. However, to reach a (near) optimal operation of the grid, these DERs should be coordinated. It is at this point that distributed control architectures come into play. The idea behind distributed control is to divide the centralized problem into a certain number of local controllers or agents. Therefore, each agent does not have a global vision of the problem [15], but by means of correct coordination they can reach a globally (near) optimal state.

Coordination is organised by a central agent that is able to communicate global constraints, such as the power limit of a transformer, or exceeding voltage limits. This can be done by the communication of Lagrange multipliers. Examples of algorithms that are suited for this approach are dual decomposition methods or the alternating direction method of multipliers (ADMM) [16]. Both are based on the dual ascent method, where price vectors are sent iteratively from the central controller to the DERs. The DERs optimize their consumption towards such a price vector and return demand vectors to the central agent. The central agent then analyses the demand vectors with regard to operational grid constraints, and updates the prices when constraints are being violated. The DERs optimize again according to this new price vector. This iteration goes on until a steady state solution is found. Figure 1(c) represents such a distributed control scheme, consisting of local DERs that optimize and a central agent that controls the global constraints.

Distributed approaches have important advantages that justify their use. As the global optimization problem is divided into several sub-problems, the computational requirements are lower. Besides, the information exchange between local and central agents is limited, which relaxes the requirements of

the communication system. This approach results in a very scalable method. As the local DERs perform an optimization by themselves, they do not need to hand over private information to a third party that controls their resources. However, a central agent still exists, inherently resulting in a single point of failure.

### D. Peer-to-Peer Control Architecture

To eliminate the problems that a more centralized control method possesses, having a single point of failure, the idea of peer-to-peer microgrids has been developed. This type of architecture, inspired by P2P computer networking [17], is characterized by the complete absence of a central controller. All local DERs or agents, are equally important and can communicate to other agents [18], in a peer-to-peer fashion, as shown in figure 1(d). The absence of a central controller leads to the term of autonomous control. Peer-to-peer communication is used for dissemination of the grid state to all required agents in the microgrid. The grid-supporting agents can then act according to the received information, in cooperation with each other. In this way they should be able to reach a (near) optimal operation of the considered microgrid. Examples of algorithms that could be used for such P2P communication are gossiping [19] and consensus algorithms [20]. This architecture will be elaborated further in section IV.

In this architecture, there is a clear absence of a single point of failure. In the case a single agent fails, the other agents can still operate the grid in a stable way. Also when a single communication channel fails, the required information can still reach all necessary participants, via other agents. These properties makes this architecture a robust way of controlling a microgrid. Besides, all information is kept local, eliminating possible privacy concerns. On the other hand, all agents need a considerable amount of local intelligence, as they need to be able to execute the necessary optimizations.

### E. Local Control Architecture

Finally, there also exist control architectures without any form of communication, as shown in figure 1(e). This paper classifies them as *local* control architectures. In this case, optimal operation of the microgrid is rather difficult, as it is impossible to know the complete state of the grid and all operational boundary conditions of the DERs. However, this method is robust against all communication failures, as the absence of any communication will ensure that the grid is still controlled when all communication channels fail. As primary frequency control should be able to operate even when communication fails, this is often implemented as a local control architecture. Thereby it uses droop characteristics that vary active power with variations in locally measured frequency. Another example is local voltage control, implemented by a voltage-reactive power droop [21].

## IV. PROPOSED PEER-TO-PEER BASED CONTROL PARADIGM FOR THE DISTRIBUTION GRID

As the new DERs are typically highly distributed in the grid, operated by a lot of different owners and with different

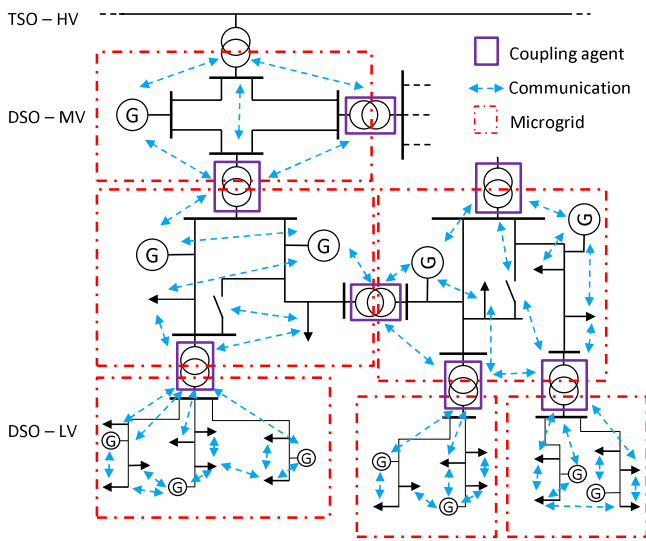

Fig. 2. P2P based control paradigm

objectives, it is desirable that the microgrid control system operates in a highly decentralized way as well. Plug and play of new resources in this microgrid is a crucial to allow for seamless integration over time. In this perspective, a peer-to-peer control architecture, as introduced in section III-D, seems to be a good method for controlling DERs in the distribution grid. It is a robust method and is able to work in a distributed way, without the need for a central controller, having inherent plug and play characteristics. Each agent communicates directly with other agents in the microgrid, without having to go through a central server [22].

It is impossible to impose this architecture on the whole distribution grid, as it incorporates thousands of DERs that are geographically very dispersed. To deal with this, breaking the complete grid down into a smaller microgrids, containing only a limited amount of DERs, can be a solution. These microgrids operate then according to the presented peer-to-peer control architecture. Points of common coupling are used to connect the different microgrids.

The proposed scheme is shown in figure 2. The distribution network is divided into several microgrids, hierarchically organized on different voltage levels. A microgrid can consist of a couple of low voltage feeders, physically connected to the same transformer, or a part of the medium voltage network on the same voltage level, for example. Each microgrid consists of several autonomous agents. Such an agent could be a renewable generation unit, a group of intelligent controllable loads, a substation, or any other form of DERs. On the connection points of two microgrids there is a coupling agent which serves as gateway of one microgrid to the other microgrid, the point of common coupling. As the microgrids represented in this figure are separated by transformers or substations, these would be good candidates for such a coupling agent. Such a coupling agent represents the characteristics of the whole

lower level microgrid (e.g. a low voltage feeder) on the higher level microgrid (e.g. a medium voltage distribution grid).

The agents are each able to communicate with some other neighbouring agents in a peer-to-peer way, creating possibilities to disseminate data about the state of the grid without the need for one central point of information. Certain algorithms from the field of distributed computing, epidemic [23], gossiping [24] and consensus [20] algorithms seem to be particularly appropriate for this goal. These algorithms are designed to disseminate and aggregate data in distributed networks in a quick and robust way, making them good candidates for P2P microgrid control.

Each agent should have some local intelligence that determines the action of the agent based on the perceived state of the grid. The agents decide their own actions, that will result in a new state of the grid. The agents obtain new information about the new state of the grid through the peer-to-peer communication, and decide on a new action based on this new state. The successive grid states should converge to a desired steady state of the grid. Appropriate control algorithms are needed to achieve this.

#### A. Epidemic Algorithms Suited for Peer-to-Peer Control

Epidemic or gossiping algorithms are used for scalable and efficient data dissemination in distributed P2P networks, without a central controller [25]. They mimic the spread of a contagious disease. Each agent in the distributed system sends new information it has received to other agents rather than to a server or cluster of servers in charge of forwarding it. In turn, each of these agents forwards the information to other selected agents, and so on [23]. Gossiping [19] is often used as a synonym for epidemic algorithms. In [26], a gossip-like distributed P2P optimization algorithm is presented for optimal reactive power flow control in a microgrid. In this method, the agents iteratively take actions that minimize the power losses in the grid, when communicating only with their neighbours. In [27], a P2P gossiping algorithm is presented for active and reactive power sharing in a microgrid, based on frequency and voltage droop control.

Consensus algorithms can be seen as a specific type of epidemic algorithms, where the goal is for all agents to reach an *agreement* on a certain quantity that depends on the states of all agents [20]. In practice, many consensus algorithms are used to calculate an average value of the states of all agents in a distributed way. This can easily be used for P2P economic dispatch of the DERs in a microgrid, where all agents have to agree on the same marginal cost [28], [29]. In [30], a consensus algorithm is used for global information discovery for peer-to-peer based load restoration to isolate faults. Consensus algorithms are applied for peer-to-peer control of DC microgrids in [31], [32].

## V. CONCLUSION

This paper discussed the major issues with regard to the integration of DERs in the electrical grid and the concept of microgrids as a possible solution to these problems. As

there are different methods for organizing the control of these microgrids found in literature, this paper presented a classification of these methods, from highly centralized to fully decentralized architectures. The drawbacks of the centralized control and the advantages of the distributed control architecture have been discussed as a motivation to propose a new control paradigm for the distributed grid, based on peer-to-peer controlled microgrids. Coupling agents are introduced to establish a connection between two microgrids.

The absence of a central point and peer-to-peer communication are found to be key elements in this control method. Epidemic algorithms, such as gossip and consensus are proposed as suited algorithms for peer-to-peer control, as they are able to disseminate data in a distributed way. Finally, a short literature review on peer-to-peer microgrid control based on gossiping and consensus algorithms is presented as an illustration of possible algorithms for peer-to-peer controlled microgrids.

Future work may consist of validation and demonstration of a peer-to-peer controlled microgrid, as well as a comparison of the performance of the different algorithms found in literature.

#### REFERENCES

- [1] R. O'Gorman and M. A. Redfern, "Enhanced autonomous control of distributed generation to provide local voltage control," in *Power and Energy Society General Meeting - Conversion and Delivery of Electrical Energy in the 21st Century, 2008 IEEE*, July 2008, pp. 1–8.
- [2] J. P. Lopes, N. Hatziargyriou, J. Mutale, P. Djapic, and N. Jenkins, "Integrating distributed generation into electric power systems: A review of drivers, challenges and opportunities," *Electric power systems research*, vol. 77, no. 9, pp. 1189–1203, 2007.
- [3] R. H. Lasseter and P. Paigi, "Microgrid: a conceptual solution," in *Power Electronics Specialists Conference, PESC*, June 2004, pp. 4285–4290.
- [4] N. Hatziargyriou, "Microgrid control issues," in *Microgrids: Architectures and Control*, 1st ed. John Wiley and Sons, 2014, ch. 3, pp. 25–80.
- [5] T. Xu and P. Taylor, "Voltage control techniques for electrical distribution networks including distributed generation," in *The International Federation of Automatic Control, 17th World Congress Seoul*, 2008.
- [6] I. A. Erinmez, D. O. Bickers, G. F. Wood, and W. W. Hung, "Ngc experience with frequency control in england and wales-provision of frequency response by generators," in *Power Engineering Society 1999 Winter Meeting, IEEE*, vol. 1, Jan 1999, pp. 590–596 vol.1.
- [7] R. H. Lasseter, "Smart distribution: Coupled microgrids," *Proceedings of the IEEE*, vol. 99, no. 6, pp. 1074–1082, June 2011.
- [8] A. Bidram and A. Davoudi, "Hierarchical structure of microgrids control system," *IEEE Transactions on Smart Grid*, vol. 3, no. 4, pp. 1963–1976, Dec 2012.
- [9] D. E. Olivares, A. Mehrizi-Sani, A. H. Etemadi, C. A. Caizares, R. Iravani, M. Kazerani, A. H. Hajimiragha, O. Gomis-Bellmunt, M. Saeedifard, R. Palma-Behnke, G. A. Jimnez-Estvez, and N. D. Hatziargyriou, "Trends in microgrid control," *IEEE Transactions on Smart Grid*, vol. 5, no. 4, pp. 1905–1919, July 2014.
- [10] M. Chenine, E. Karam, and L. Nordstrom, "Modeling and simulation of wide area monitoring and control systems in ip-based networks," in *2009 IEEE Power Energy Society General Meeting*, July 2009, pp. 1–8.
- [11] A. Mohamed, A. Ghareeb, T. Youssef, and O. A. Mohammed, "Wide area monitoring and control for voltage assessment in smart grids with distributed generation," in *Innovative Smart Grid Technologies (ISGT), 2013 IEEE PES*, Feb 2013, pp. 1–6.
- [12] S. Sojoudi, J. Lavaei, and A. G. Aghdam, *Structurally Constrained Controllers: Analysis and Synthesis*. Springer Science and Business Media, 2011, ch. 1, pp. 1–8.
- [13] S. Vandael, B. Claessens, M. Hommelberg, T. Holvoet, and G. Deconinck, "A scalable three-step approach for demand side management of plug-in hybrid vehicles," *IEEE Transactions on Smart Grid*, vol. 4, no. 2, pp. 720–728, June 2013.
- [14] L. Che, M. Shahidehpour, A. Alabdulwahab, and Y. Al-Turki, "Hierarchical coordination of a community microgrid with ac and dc microgrids," *IEEE Transactions on Smart Grid*, vol. 6, no. 6, pp. 3042–3051, Nov 2015.
- [15] M. Yazdani and A. Mehrizi-Sani, "Distributed control techniques in microgrids," *IEEE Transactions on Smart Grid*, vol. 5, no. 6, pp. 2901–2909, Nov 2014.
- [16] D. Alaerts and J. De Turck, "Investigation and comparison of distributed algorithms for demand-side management," Master's thesis, ESAT-ELECTA, KU Leuven, 2013.
- [17] R. Schollmeier, "A definition of peer-to-peer networking for the classification of peer-to-peer architectures and applications," in *Peer-to-Peer Computing, 2001. Proceedings. First International Conference on*, Aug 2001, pp. 101–102.
- [18] S. D. J. McArthur, E. M. Davidson, V. M. Catterson, A. L. Dimeas, N. D. Hatziargyriou, F. Ponci, and T. Funabashi, "Multi-agent systems for power engineering applications—part i: Concepts, approaches, and technical challenges," *IEEE Transactions on Power Systems*, vol. 22, no. 4, pp. 1743–1752, Nov 2007.
- [19] D. Kempe, A. Dobra, and J. Gehrke, "Gossip-based computation of aggregate information," in *Foundations of Computer Science, 2003. Proceedings. 44th Annual IEEE Symposium on*, Oct 2003, pp. 482–491.
- [20] R. Olfati-Saber, J. A. Fax, and R. M. Murray, "Consensus and cooperation in networked multi-agent systems," *Proceedings of the IEEE*, vol. 95, no. 1, pp. 215–233, Jan 2007.
- [21] E. Demirok, P. C. Gonzalez, K. H. B. Frederiksen, D. Sera, P. Rodriguez, and R. Teodorescu, "Local reactive power control methods for overvoltage prevention of distributed solar inverters in low-voltage grids," *IEEE Journal of Photovoltaics*, vol. 1, no. 2, pp. 174–182, Oct 2011.
- [22] K. Eger, C. Gerdes, and S. Ztunali, "Towards p2p technologies for the control of electrical power systems," in *2008 Eighth International Conference on Peer-to-Peer Computing*, Sept 2008, pp. 180–181.
- [23] P. T. Eugster, R. Guerraoui, A. M. Kermarrec, and L. Massoulié, "Epidemic information dissemination in distributed systems," *Computer*, vol. 37, no. 5, pp. 60–67, May 2004.
- [24] A. G. Dimakis, S. Kar, J. M. F. Moura, M. G. Rabbat, and A. Scaglione, "Gossip algorithms for distributed signal processing," *Proceedings of the IEEE*, vol. 98, no. 11, pp. 1847–1864, Nov 2010.
- [25] A. Demers et al., "Epidemic algorithms for replicated database maintenance," in *Proceedings of the Sixth Annual ACM Symposium on Principles of Distributed Computing*, ser. PODC '87. New York, NY, USA: ACM, 1987, pp. 1–12.
- [26] S. Bolognani and S. Zampieri, "A gossip-like distributed optimization algorithm for reactive power flow control," in *Proc. IFAC World Congress*, 2011, pp. 1–14.
- [27] K. De Brabandere, "Voltage and frequency droop control in low voltage grids by distributed generators with inverter front-end," Ph.D. dissertation, KU Leuven, 2006.
- [28] J. Cao, "Consensus-based distributed control for economic dispatch problem with comprehensive constraints in a smart grid," Ph.D. dissertation, The Florida State University, 2014.
- [29] Z. Zhang and M. Y. Chow, "Incremental cost consensus algorithm in a smart grid environment," in *2011 IEEE Power and Energy Society General Meeting*, July 2011, pp. 1–6.
- [30] Y. Xu and W. Liu, "Novel multiagent based load restoration algorithm for microgrids," *IEEE Transactions on Smart Grid*, vol. 2, no. 1, pp. 152–161, March 2011.
- [31] L. Meng, T. Dragicevic, J. Roldn-Prez, J. C. Vasquez, and J. M. Guerrero, "Modeling and sensitivity study of consensus algorithm-based distributed hierarchical control for dc microgrids," *IEEE Transactions on Smart Grid*, vol. PP, no. 99, pp. 1–1, 2015.
- [32] L. Meng, T. Dragicevic, J. M. Guerrero, and J. C. Vasquez, "Dynamic consensus algorithm based distributed global efficiency optimization of a droop controlled dc microgrid," in *Energy Conference (ENERGYCON), 2014 IEEE International*, May 2014, pp. 1276–1283.