

Targeting virus-host interactions of HIV replication

Caroline Weydert, Jan De Rijck, Frauke Christ and Zeger Debyser*

Laboratory for Molecular Virology and Gene Therapy, Department for Pharmaceutical and Pharmacological Sciences, KU Leuven, Leuven, Flanders, Belgium

Abstract: Cellular proteins that are hijacked by HIV in order to complete its replication cycle, form attractive new targets for antiretroviral therapy. In particular, the protein-protein interactions between these cellular proteins (cofactors) and viral proteins are of great interest to develop new therapies. Research efforts have led to the validation of different cofactors and some successes in therapeutic applications. Maraviroc, the first cofactor inhibitor approved for human medicinal use, provided a proof of concept. Furthermore, compounds developed as Integrase-LEDGF/p75 interaction inhibitors (LEDGINs) have advanced to early clinical trials. Other compounds targeting cofactors and cofactor-viral protein interactions are currently under development. Likewise, interactions between cellular restriction factors and their counteracting HIV protein might serve as interesting targets in order to impair HIV replication. In this respect, compounds targeting the Vif-APOBEC3G interaction have been described. In this review, we focus on compounds targeting the Integrase-LEDGF/p75 interaction, the Tat-P-TEFb interaction and the Vif-APOBEC3G interaction. Additionally we give an overview of currently discovered compounds presumably targeting cellular cofactor-HIV protein interactions.

Keywords: HIV, cofactors, APOBEC3G, antivirals, LEDGF/p75, LEDGIN, P-TEFb

1. INTRODUCTION

With a cure or vaccination against HIV infection still out of reach, continued research on new antiviral therapies is warranted. Although existing combined anti-retroviral therapy (cART) is effective in controlling viremia, the occurrence of HIV drug resistance (HIVDR) remains a challenge¹. The high mutation rate resulting in extensive genetic diversity and the escape from cART in latently infected cells, along with poor patient compliance, all contribute to the emergence of resistant strains and treatment failure. With the purpose of preventing cross resistance between drug classes, it is essential to identify new therapeutic targets. Like all other viruses, HIV obligatory relies on cellular pathways and proteins (here referred to as cofactors) to complete its replication cycle. On the other hand, cells defend themselves against infection by use of so-called restriction factors. During the last decade the scientific community has realized that virus-host interactions constitute a valuable alternative source of antiviral targets. Systematic validation of assumed cofactors as druggable targets is crucial in this process (reviewed in²). This new line of research led to the development of a variety of new compounds currently in various stages of drug development and the FDA/EMA approval of the first cofactor inhibitor, maraviroc (Selzentry[®] in the US, Celsentry[®] outside US, ViiV Healthcare)³. This compound

blocks HIV-entry upon binding to the human C-C chemokine type 5 receptor (CCR5), one of the HIV co-receptors. Other compound classes are currently in clinical trials or in earlier development. An overview is given in **table 1**.

Impairing HIV replication through inhibition of viral-host interactions could benefit from a reduced risk of antiviral resistance. Indeed, cellular proteins are less prone to evolutionary adaptations, giving the virus theoretically less opportunities for resistance development. Inhibitors could potentially be developed to interfere specifically with the function of the cellular protein itself. For example, compounds inhibiting the DDX3 ATPase activity cause a block in HIV replication at non-toxic concentrations (**table 1**)⁴. DDX3, necessary for viral RNA (vRNA) export, is a binding partner of the viral Rev protein. Alternatively, kinase-activity can be inhibited: either from kinases directly interacting with HIV proteins, or from kinases playing a role in pathways important for HIV disease progression. Targets include the kinase activity of CDK9 and HCK, which respectively interact with HIV Tat and Nef (illustrated in **table 1**)⁵. However, this strategy is quite challenging, as most kinase inhibitors lack specificity and affect downstream processes, leading to toxicity.

An alternative strategy could be to target specifically the protein-protein interaction between a cofactor and its interacting viral protein. For example, maraviroc and tirofiban (Aggrastat[®], Eumedica) are FDA approved drugs targeting protein-protein interactions³.

*Address correspondence to this author at the Laboratory for Molecular Virology and Gene Therapy, Department for Pharmaceutical and Pharmacological Sciences, KU Leuven, Kapucijnenvoer 33 VCTB+5, Leuven, Flanders, Belgium; Tel/Fax: +3216332183, +3216336336; E-mail: zeger.debyser@med.kuleuven.be

Table 1. Overview of compounds targeting interactions between HIV proteins and cellular cofactors.

Event	Viral protein	Cellular cofactor	Mechanism	Compound classes and examples	Development stage	Reference/company
Entry	GP-120	CCR5	Binding to CCR5	CCR5 antagonists: Maraviroc (UK-427857) (Selzentry®/Celsentry®) PF-232798 Aplaviroc (GSK-873140/AK602) GSK-706769 Vicriviroc (SCH-417690) SCH-532706 INCB009471 Cenicriviroc (TBR652)	Approved for human medicinal use ³ Phase II ⁶ Stopped at phase III ⁷ Phase I ⁷ Stopped at phase III ⁷ Phase I ⁸ Stopped at phase II ⁷ Phase II ⁷	Viiv-healthcare (Pfizer) Viiv-healthcare (Glaxo-Smith Kline) Schering-Plough (Merck) Incyte Corporation Tobira Therapeutics, Inc.
			NK ₁ -receptor antagonist, leads to decreased CCR5-expression	Aprepitant (Emend®)	Approved as anti-emetic In Phase 1	Merck
	GP-120	CXCR4	Binding to CXCR4 (allosteric modulator)	CXCR4 antagonists: AMD070, AMD3100 ¹ GSK812397	Stopped phase I/II ⁷ Preclinical ⁹	AnorMed ¹⁰ Viiv-healthcare (Glaxo-Smith Kline)
	GP-120	CD4	Binding to GP-120 and induction of conformational changes	Attachment inhibitors: BMS-663068 (fostemsavir) BMS-378806 NBD-556 and NBD-557	Phase III ¹¹ Stopped at phase I Drug Discovery	Reviewed in. ¹²
			CD-4 downregulation	Cyclotriazadisulfonamide (CADA) and analogues	Pre-clinical	
	Uncoating and assembly	Capsid	Cyclophilin A	Dual binding	Thiourea derivatives: K17, K24, K25	Drug Discovery
Binding to Capsid interface on Cyclophilin A				Methoxyphenyltriazolecarboxamide based compounds	Drug Discovery	Tian et al. 2013 ¹⁵

			Inhibition of Cyclophilin A activity ²	Peptidylprolyl isomerase A inhibitors: FD5, FD8-10, FD12	Drug discovery	Chen <i>et al.</i> 2007 ¹⁶
Reverse transcription	Vif	APOBEC3G	Vif destabilization/downregulation	RN-18	Drug discovery	Nathans <i>et al.</i> 2008 ¹⁷
			A3G stabilization	IMB-26, IMB-28	Drug Discovery	Cen <i>et al.</i> 2010 ¹⁸
			Binding likely to APOBEC3G	N.41	Drug Discovery	Pery <i>et al.</i> 2015 ¹⁹
Integration and maturation	Integrase	LEDGF/p75	Binding to the LEDGF/p75 pocket on Integrase	LEDGINS, ALLINIs, NCINIs: BI224436	Phase I	Patents reviewed in ²⁰
Vpr nuclear import	Vpr	Importin- α	Binding likely to Vpr	Hematoxylin	Drug Discovery	Suzuki <i>et al.</i> 2009 ²¹
LTR-transactivation	Vpr	Glucocorticoid receptor (GR)	GR-antagonist	Mifepristone	Phase I/II ²²	Schafer <i>et al.</i> 2006 ²³ Refaeli <i>et al.</i> 1995 ²⁴
Transcription	Tat	P-TEFb	CDK9 kinase inhibitors	ATP site antagonists: Flavopiridol and analogues ² Roscovitine and analogues ² Indirubin 3'-Monoxime 2-phenylquinazolinone fragments	Drug discovery Anti-cancer compound Anti-cancer compound	Chao <i>et al.</i> 2000 ²⁵ Wang <i>et al.</i> 2001 ²⁶ Heredia <i>et al.</i> 2005, 2013 ²⁷ Sancineto <i>et al.</i> 2013 ²⁸
			Binding to CDK9 interaction interface with Tat	5-Ar-3-oxymethyl-Ar-1,2-oxazole compound	Drug discovery	Van Duyne <i>et al.</i> 29
			Binding to Cyclin-T1 interaction interface with Tat	Benzothiadiazole-sulfonamides: C1, C2, C3	Drug discovery	Hamasaki <i>et al.</i> 2012 ³⁰
Nuclear export	Rev	EIF5 α	Inhibition of deoxyhypusine synthesis resulting in low EIF-5A activation ²	S-adenosylmethionine decarboxylase-inhibitors SAM486A (sardomozide)	Drug discovery Anti-cancer compound	Schäfer <i>et al.</i> 2006 ³¹
				Deoxyhypusine synthase inhibitors: CNI-1493 (semapimod)	Drug discovery Anti-inflammatory compound	Hauber <i>et al.</i> 2005 ³²
		Crm1	Binding to Crm1 and disruption of Crm1-Rev	PKF050-638 ³ Ratjadone A ⁴	Drug discovery	Daelemans <i>et al.</i> 2002 ³³ Fleta-Sorjano <i>et al.</i> 2014 ³⁴

			interaction	Valtrate		Murakami <i>et al.</i> 2002 ³⁵
		Crm1-DDX3	Inhibition of DDX3 ATPase activity ²	ATP site antagonists Ring expanded nucleoside analogues Rhodanine derivatives	Drug discovery	Yedavalli <i>et al.</i> 2008 ³⁶ Maga <i>et al.</i> 2008, 2011 ^{4, 37}
			Binding to DDX3 RNA binding site	<i>N,N'</i> -diarylureas	Drug discovery	Radi <i>et al.</i> 2012 ³⁸
Promotion of HIV pathogenesis: MHC-1 down-regulation	Nef	HCK	Binding to HCK-SR3 binding pocket on Nef	D14, DLC27 and analogues DQBS (diaminoquinoxaline benzenesulfonamide)	Drug discovery	Betzi <i>et al.</i> 2007 ³⁹ Trible <i>et al.</i> 2013 ⁴⁰ Reviewed in ⁴¹
			Binding to Nef → allosteric	2c (= 2,4-dihydroxy-5-(1-methoxy-2-methylpropyl)benzene-1,3-dialdehyde)	Drug discovery	Dikeakos <i>et al.</i> 2010 ⁴²
			Disruption of Nef dimerization	Diphenylpyrazolodiazenes: B9	Drug discovery	Emert-Sedlak <i>et al.</i> 2013 ⁴³
			Binding likely to the Hck active site	Diphenylfuopyrimidines: DFP4A	Drug discovery	Emert-Sedlak <i>et al.</i> 2009 ⁴⁴
Promotion of HIV pathogenesis including CD4 down-regulation	Nef	p56 ^{lck} , p53, Actin	Binding to Nef N-terminus	Guanidine alkaloid analogs ⁴	Drug discovery	Olszewski <i>et al.</i> 2004 ⁴⁵

¹ Long term toxicity *in vivo*² (Expected to) have off target effects or downstream toxic effects³ Not tested on HIV-replication⁴Toxic

Tirofiban is an anti-aggregans indicated for the treatment of acute coronary angioplasty and instable angina. It inhibits blood platelet aggregation by blocking the interaction between glycoprotein IIb/IIIa receptors on platelets and fibrinogen and other ligands. However, targeting protein-protein interfaces could be quite challenging, as they contain often flat, weakly defined and hydrophobic surfaces⁴⁶.

Cofactor interaction inhibitors can either target the viral protein or the cellular factor. In the first case, resistance mutations, inhibiting the interaction with the small molecule, should not hamper the interaction with the cellular protein. Alternatively, resistant viruses could develop mechanisms to replicate independently from the cofactor or evolve to use alternative cofactors (recently reviewed in⁴⁷). In the second case the virus will escape a viral cofactor bound by a small molecule. Ideally, a druggable cofactor is crucial for HIV replication, but not for cell survival, as for example CCR5. Indeed, humans with a 32 basepair deletion in the *ccr5* gene, which leads to the absence of the receptor on the cell surface, are healthy and naturally resistant to HIV infection⁴⁸.

In this review we will focus on the development of different drug classes targeting interactions of HIV proteins with human cofactors. As another review in this journal discusses entry-inhibitors in detail, we focus on compounds inhibiting other important cofactor-HIV protein interactions, namely inhibitors of Integrase-LEDGF/p75, Tat-P-TEFb and Vif-APOBEC3G.

2. AN INTRODUCTION TO COFACTORS AND RESTRICTION FACTORS OF HIV REPLICATION

The HIV genome (10 kb) encodes the Gag, Pol, Env proteins, the regulatory proteins, Tat and Rev and the accessory proteins, Vif, Vpr, Vpu and Nef. After protease cleavage, the Gag protein is cleaved into Matrix, Capsid (CA), Nucleocapsid, Spacer peptides 1 and 2, and p6, the Pol polyprotein into Reverse transcriptase (RT), Integrase (IN) and Protease, the Env into gp120 and gp41. In order to regulate and complete HIV replication, most, if not all, viral proteins interact with cellular proteins (cofactors).

Efforts identifying these cellular proteins included genome wide siRNA screens⁴⁹, yeast two-hybrid screens⁵⁰ and large scale co-immunoprecipitation experiments followed by the identification of cellular interaction partners through mass spectrometry⁵¹. Further virological and biochemical validation of these hits led to the discovery of cofactors involved in different steps of HIV replication, as shown in **Figure 1**. Out of the plethora of identified cofactors we focus on those cofactors explored for drug development.

- **HIV entry (Figure 1A):** Interactions of the CD4 receptor and the CCR5 or CXCR4 co-receptors with viral gp120 are essential for HIV attachment and entry and are currently a target of several drugs⁵².
- **Reverse transcription (Figure 1B):** CDK2 was demonstrated to support HIV RT activity in CD4

positive T-cells, through phosphorylation of RT⁵³. This phosphorylation leads to an increase in activity and a stabilization of RT.

- **HIV uncoating and nuclear import of the pre-integration complex (Figure 1B, 1C):** Cyclophilin A (CypA) has been described to interact with the viral CA and to play a role in capsid stability facilitating viral replication⁵⁴. Also CPSF6 (cleavage and polyadenylation specific factor 6) and a non-physiologic truncation mutant (CPSF6-358) have been described to interact with the CA protein⁵⁵. The function of this interaction is however still a matter of debate. In addition, the Importin- β -like protein Transportin-SR2 (TNPO3) and RANBP2 (RAN binding protein 2), also known as Nucleoporin 358 (Nup358), have been implicated in the import of the pre-Integration Complex (PIC) into the nucleus⁵⁶.
- **Integration (Figure 1D):** LEDGF/p75, an IN interaction partner, is responsible for tethering the PIC to the host chromatin and thereby targeting integration into the body of active genes. The interaction with LEDGF/p75 has been shown to be essential for HIV replication (reviewed in^{2b}).
- **HIV transcription and vRNA export (Figure 1E):** The Positive Transcription Elongation Factor P-TEFb complex interacts with HIV Tat in order to activate RNA Polymerase II and promote elongation of viral transcripts^{5a}. The importin- β CRM1 and the Dead box helicase DDX3 interact with the Rev protein in order to export unspliced RNA transcripts⁵⁷. Also proteins interacting with the viral LTR and DNA/RNA have been described and can be considered cofactors.
- **Budding and viral assembly (Figure 1F):** TSG101, an ESCRT I component, was found to interact with Gag-p6 and to be essential for HIV budding⁵⁸. Also for ALIX (or Programmed cell death 6-interacting protein, PDC6I), binding to p6 and components in the ESCRT III pathway, a role in the budding process was elucidated⁵⁹.

For the accessory protein Nef, different binding partners have been described as well, amongst them the Tyrosine protein kinase HCK (**table 1**)^{5b}. Binding of Nef to HCK triggers down-regulation of cell-surface MHC-I. Furthermore, different host-encoded restriction factors have been described, including APOBEC3G (A3G) and Tetherin (BST2). Restriction factors can serve as efficient inhibitors of viral replication, but are often counteracted by HIV accessory proteins. For instance, APOBEC3F/G (A3F/G), exerts innate antiretroviral immune activity by interfering with retroviral replication; however, HIV can counteract its effect by the Vif accessory protein⁶⁰. Therefore inhibition of this interaction should in theory hamper viral replication. Tetherin – another restriction factor and part of the IFN-dependent antiviral response pathway - interferes with the release of virions by preventing the release of virus particles

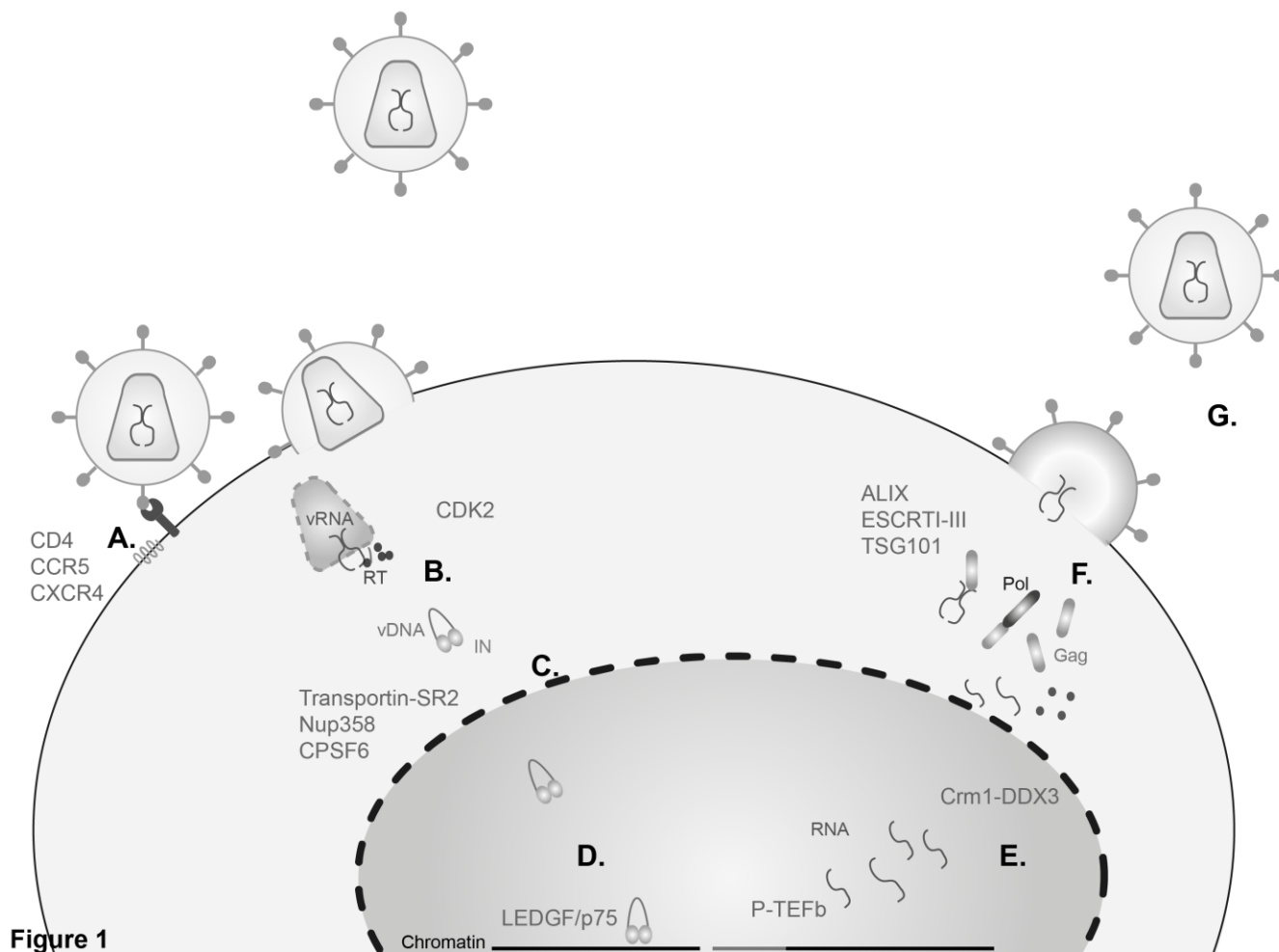

Figure 1

Figure 1, HIV replication cycle. **A.** The virus enters the cell through interaction with the CD4 receptor and the CCR5 or CXCR4 co-receptor. **B.** After entry, partial uncoating, reverse transcription of the viral RNA (vRNA) into double stranded DNA (vDNA) takes place. **C.** A pre-integration complex (PIC) is formed and transported into the nucleus. **D.** The PIC binds to LEDGF/p75 and is targeted to the host chromatin. Integration of the vDNA into the host chromatin is catalysed by the viral Integrase (IN). **E.** After integration, the vDNA is silenced or transcribed into vRNA. Accessory proteins, including Tat, are expressed. Tat will recruit P-TEFb leading to elongation of viral transcripts. Spliced vRNA's are exported to the cytoplasm and translated into the Gag and Gag-Pol precursor proteins. Unspliced full length vRNA binds through its Rev Responsive Element to Rev, which interacts with Crm1 and DDX3 in order to be exported. **F.** The viral precursor proteins Gag and Gag-Pol and the vRNA bud at the plasma membrane, a process mediated by TSG101. New virions are released through the ESCRT I and III pathways. **G.** The precursor proteins are cleaved by the viral protease and mature virions are formed.

from infected cells (**Figure 2G**). The presence of Tetherin in the plasma membrane is down-regulated through its interaction with Vpu.

3. TARGETING THE INTEGRASE-LEDGF/p75 INTERACTION

The interaction of LEDGF/p75 with HIV IN is essential for HIV integration and as such for HIV replication⁶¹. As compounds inhibiting integration by targeting IN catalytic activity, have been a clinical success, developing compounds

interfering with the binding of LEDGF/p75 to IN, provide a valuable complementary strategy³.

3.1. Integration of the viral DNA into the host cell chromatin

The viral IN catalyses the insertion of viral DNA (vDNA) into the host genome through 2 distinct reactions: 1) During the 3' processing reaction in the cytoplasm, a dinucleotide at both 3' ends of the vDNA is removed revealing the invariant CA_{OH}-3' ends. 2). Upon transport of the PIC to the nucleus,

the strand transfer reaction takes place. During this reaction the recessed vDNA ends are inserted 4-6 base pairs apart into opposing strands of the cellular DNA (recently reviewed in ⁶²). The single-stranded gaps in the resulting DNA recombination intermediate are repaired by the host cell machinery. The viral IN consists of 3 domains: an N-terminal domain (NTD), a catalytic core domain (CCD) and a C-terminal domain (CTD) (**Figure 2**). The NTD has a HHCC zinc binding motif which stabilizes its 3 helix bundled structure. The CCD contains the DDE triad, which coordinates two magnesium ions responsible for its catalytic activity. The CTD forms a 5-stranded β -barrel. All three

domains are involved in DNA binding and multimerization. In order to be functional, IN needs to form at least a dimer for the 3' processing reaction and a tetramer for the strand transfer reaction (recently reviewed in ⁶²)

Targeting the IN catalytic activity has shown to be a valuable approach, as illustrated by the approval of the inhibitors raltegravir (Isentress[®]), elvitegravir (in Stribild[®]) and dolutegravir (Tivicay[®]) ³. Those compounds inhibit the IN strand transfer reaction and therefore are referred to as INSTIs (Integrase Strand Transfer Inhibitors). Inhibition of integration results in a strong reduction in viral load.

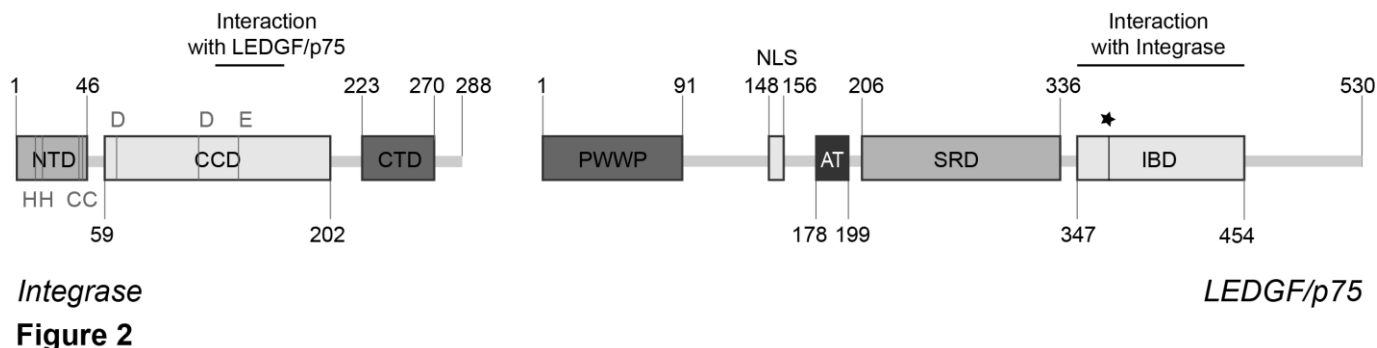

Figure 2, LEDGF/p75 and Integrase domains. A schematic representation of HIV Integrase and LEDGF/p75. HIV Integrase contains an N-terminal domain (NTD), a catalytic core domain (CCD) and a C-terminal domain (CTD). LEDGF/p75 contains N-terminally a PWWP-domain (PWWP), a nuclear localisation signal (NLS), two AT-hook motifs (AT) and a supercoiled recognition domain (SRD). C-terminally it contains the Integrase binding domain (IBD) responsible for protein and integrase binding. The D366 residue responsible for integrase binding is marked by a star.

3.2. The role of LEDGF/p75 during HIV replication

After its initial discovery as an IN binding partner in 2003 ⁶³, LEDGF/p75 got thoroughly validated as an essential cofactor of HIV integration (reviewed in ^{2a} and ^{2b}). Briefly, mutagenesis, RNA interference, transdominant overexpression of the Integrase binding domain (IBD) of LEDGF/p75 and KO studies demonstrated the importance of LEDGF/p75 during viral replication.

LEDGF/p75, a 530 amino acid nuclear protein, is a member of the Hepatoma Derived Growth Factor (HDGF) family. It is encoded by the *PSIP1* gene, located on chromosome 9p22.2, together with its smaller splice variant LEDGF/p52 ⁶⁴. All HDGF proteins are characterised by an N-terminal PWWP-domain recognizing H3K36 tri-methylated chromatin ⁶⁵. Next to this, LEDGF/p75 and its splice variant share a nuclear localisation signal (NLS), two DNA binding AT-hooks and charged regions forming a supercoiled-DNA recognition domain (SRD) ⁶⁶. The p75 specific C-terminal tail is characterised by the presence of the IBD, known to interact with lentiviral integrases ⁶⁶⁻⁶⁷ and several other cellular proteins ⁶⁸ (**Figure 2**). Due to the presence of the IBD and its histone and DNA binding properties, LEDGF/p75 is able to tether and target HIV into active

chromatin ⁶⁹. Next to its tethering function, LEDGF/p75 stabilizes IN multimers, promotes IN catalytic activity *in vitro* and protects IN from proteosomal degradation ⁷⁰.

According to the crystal structure of the LEDGF/p75 IBD with the CCD of HIV-IN, the LEDGF/p75 IBD monomer, a compact right handed bundle of 5 alpha-helices, binds to a well-defined pocket formed by a dimer of IN CCDs (**Figure 3A, 3B**) ⁷¹. The IBD recognizes residues 168-171 from the first monomer and a hydrophobic patch formed by the backbones of alpha-helices 1 and 3 of the second monomer (**Figure 3B**). The critical LEDGF/p75 residues are I365, D366 and F406. The relevance of this crystal structure was confirmed by mutagenesis studies ⁷².

3.3. Targeting the LEDGF/p75 Integrase interaction

While knockdown, knockout and mutational analysis revealed that LEDGF/p75 is crucial for viral replication, overexpression of the IBD or LEDGF/p75 based peptides validated the LEDGF/p75-IN interaction as a druggable target ⁷³. Overexpression of the IBD outcompetes endogenous LEDGF/p75 from the PIC, blocking interaction of the PIC with the chromatin and thereby viral replication ^{72a, 73a}. Cyclic peptides directly binding to LEDGF/p75

**Figure 3**

Figure 3, LEDGINs bind to the LEDGF/p75 binding pocket on HIV-1 IN. Structures are shown of the LEDGF/p75 IBD or C3 in complex with HIV-1 Integrase (IN), based on pymol ID 2B4J and 3LPI. **A.** The LEDGF/p75 Integrase binding domain (IBD) (black) binds into a pocket formed by two Integrase catalytic domains (CCD1 in white and CCD2 in grey). **B.** Detail of LEDGF/p75 IBD binding to the CCD dimerization interface. LEDGF/p75 residue I365 sits in a hydrophobic pocket, which contains W132 and A128, and makes a hydrogen bond with the backbone amide of CCD1 residue Q168. LEDGF/p75 residues F406 and V408 interact with W131 in CCD2. The LEDGF/p75 key residue for IN binding, D366, makes a double hydrogen bond with the main-chain amides of E170 and H171 of CCD1. Furthermore, the CCD1 E170 also makes a salt bridge with LEDGF/p75 K364. **C., D.** C3 binds into the IN LEDGF/p75 binding pocket and is able to displace LEDGF/p75. The consensus pharmacophore of LEDGIN development was based on LEDGF/p75 residues I365, D366 and L368⁷⁴. Figures were adapted with PyMOL software⁷⁵.

were able to inhibit LEDGF/p75 binding to Integrase and as a consequence HIV replication⁷⁶. Peptides developed by Al-Mawsawi *et al.* modestly inhibited IN catalysis *in vitro*; this inhibition was dependent on IN-DNA assembly^{73c}. These data together with the IBD-CCD co-crystal structure (PDB ID 2BJ) and a structure of the CCD with the LEDGF/p75 binding pocket occupied by tetraphenylarsonium (PDB ID 1HYV), enabled the rational design of small molecules binding the IN CCD dimer interface inhibiting the LEDGF/p75 interaction^{71, 74, 77}. Apart from structure based design, different other approaches were used to develop compounds targeting the LEDGF/p75 – IN interaction, including high throughput screening (reviewed in^{2b}). By now, most pharmaceutical companies with a HIV program are involved in the development of these inhibitors (patents reviewed in²⁰).

The structure based approach led to the discovery of 2-(quinolin-3-yl)acetic acids as the first in class compounds targeting the LEDGF/p75 binding pocket on HIV IN⁷⁴ (**Figure 4, table 2**). Fitting of a 200 000 compound library against a consensus pharmacophore model (**Figure 3B**) and evaluation of the best hits in a LEDGF/p75-IN AlphaScreen interaction assay, led to the discovery of C1 (**1**). Validation and optimization by medicinal chemistry resulted in C3 (**2**) which inhibited HIV_{IIIB} replication in MT-4 cells with an EC₅₀ of 41.9 ± 1.1 µM and the LEDGF/p75-IN interaction with an IC₅₀ of 12.2 ± 3.4 µM⁷⁴. Co-crystallization of this compound (**2**) (**Figure 3 C**), and subsequent optimization resulted in the more potent inhibitors CX05168 (**3**), CX05045 (**4**) and CX014442 (**5**)⁷⁸, inhibiting HIV replication in the nanomolar range (**table 2**). Of note, CX014442 showed an EC₅₀ of 69±3 nM and a selectivity index (SI) of 1391, similar to that of FDA approved HIV-drugs. The inhibitors were found to inhibit Integrase allosterically during 3' processing and strand transfer when the compound and IN were pre-incubated before the addition of LTR - or target DNA. Of note, similar compounds with an indole scaffold which are able to interrupt the LEDGF/p75-IN interaction *in vitro* were described by De Luca *et al.* in 2009 and optimized later on⁷⁹.

In an independent approach, Boehringer-Ingelheim (BI) identified similar compounds, Tert-butoxy-(4-phenylquinolin-3yl)-acetic acids (**Figure 4, table 2**), inhibiting the 3' processing reaction (NCINI or non-catalytic site Integrase inhibitors) (**6, 7, 8**)⁸⁰. Medicinal chemistry in combination with rational design, led to the discovery of BI224436 (**9**), which inhibits the 3' processing reaction with an IC₅₀ of 19 ± 4 nM and also binds in the LEDGF/p75 binding pocket on the IN CCD^{80b}. This compound was tested for safety and pharmacokinetics in a phase I clinical trial, as it showed excellent antiviral activity and acceptable pharmacokinetic characteristics *in vitro*^{7, 80a}. The compound exhibited a low clearance due to enterohepatic recirculation of the parent and acyl glucuronide metabolite. This observation prompted

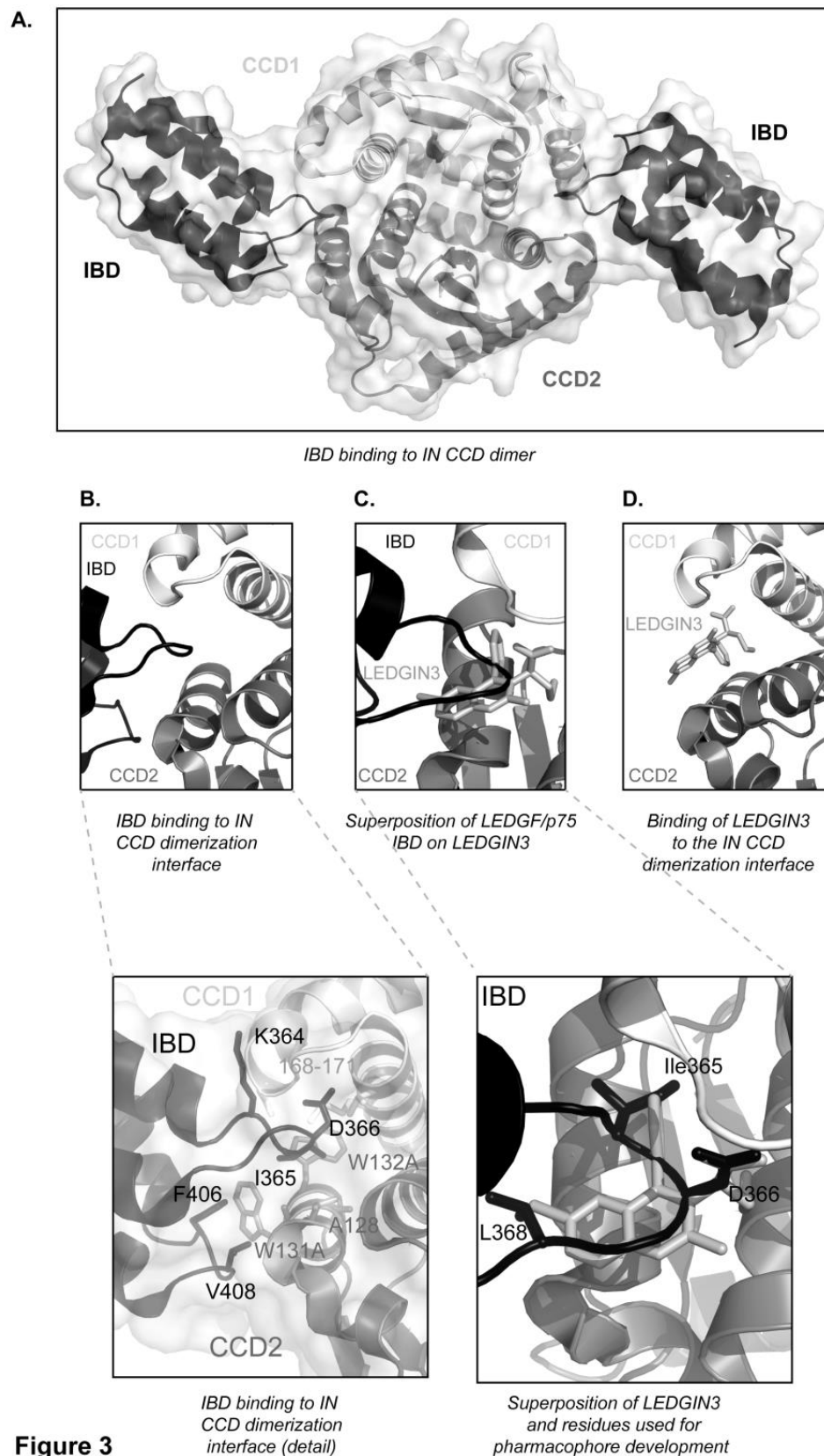
the researchers to optimize the compound through a scaffold replacement approach which resulted into a pyridine based compound (BI compound 20 (**10**)) with a reduced biliary excretion in rat⁸¹. These compounds were also described by Sharma *et al.* as multimerization selective inhibitors of HIV Integrase⁸².

Many other compounds with similar biochemical and virological properties have since been disclosed⁸³ (reviewed in²⁰). Since all compounds bind to the LEDGF/p75 binding pocket of HIV-1 Integrase, we proposed the class name of **LEDGINS**. Other potential inhibitors of the LEDGF/p75 – IN interaction have been described such as atorvastatin (only tested *in vitro*), natural product derivatives, acylhydrazones and diketo-acids⁸⁴, although no co-crystals are available for these inhibitors.

3.4. Mechanism of inhibitors targeting the LEDGF/p75 Integrase pocket.

LEDGINS displace LEDGF/p75 from the IN pocket, and enhance IN multimerization.^{74, 78, 83a, 83c, 85} They show activity against a broad spectrum of HIV clades (HIV_{IIIB}, HIV_{BAL}, HIV_{U2}, HIV_{NL4.3}, HIV_{HXB2}) and clinical isolates, but not against HIV-2 and SIV, due to a different amino acid at position IN 128, which interacts with I365 included in the pharmacophore^{74, 80b}. The resistance mutation IN A128T is responsible for an 8.65- to 11-fold change of the EC₅₀ of CX05045 (**4**) and CX014442 (**5**), respectively while A128N and L102F induce a 64- and 60-fold change of the EC₅₀ of BI224436 (**9**). Other single resistance mutations identified are the Y99H, Y99N A129T and H171T^{78, 86}. Although LEDGINS block early replication at the integration step, no resistance to INSTIs was observed with LEDGIN-resistant viruses. Furthermore, LEDGINS act additively or slightly synergistically with INSTIs, and with most NRTIs, NNRTIs, PIs and entry inhibitors^(78, 80b). LEDGINS display steep dose-response curves, resulting in EC₉₅ values only ~2.4-fold higher than the EC₅₀ values^{74, 80b, 85b, c}. Such steep Hill slopes are of importance as they indicate that at clinically relevant compound concentrations, these inhibitors can have a more pronounced effect on viral suppression^{80b}. LEDGINS affect 3' processing and strand transfer *in vitro*. CX014442 (**5**) could inhibit the IN strand transfer reaction with an IC₅₀ of 146 nM when incubated with HIV-IN prior to addition of the HIV LTR⁷⁸. 3' processing was inhibited to a same extent. Also BI-1001 (**7**) impaired strand transfer and 3' processing with similar potency (IC₅₀= 1.7 and IC₅₀=2.3 respectively)^{85c}. Integration inhibition *in vitro* can be explained by enhanced IN multimerization^{78, 85c}. *In vivo*, LEDGINS exhibit an enhanced potency in LEDGF/p75 knock-out cells, pointing out the necessity of displacing LEDGF/p75 during the early stage of HIV replication^{61d}. In conclusion, inhibition of integration is due to the displacement of LEDGF/p75 and to a LEDGIN-induced increase in the stability of the IN multimer; both mechanisms cannot be uncoupled in the infected cell^{2b}.

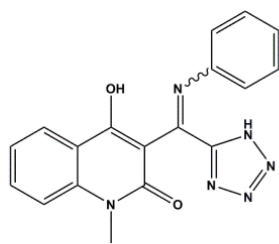

Compound 1 (1)

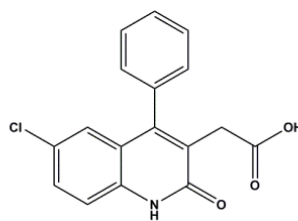

Compound 3 (2)

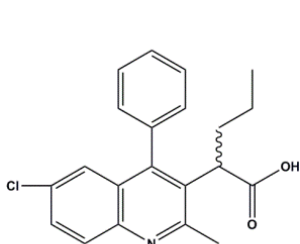

CX05168 (3)

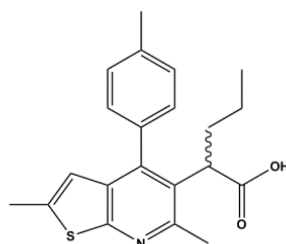

CX05045 (4)

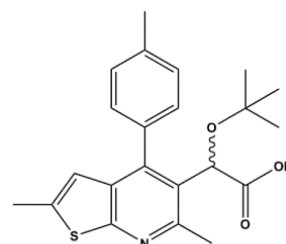

CX14442 (5)

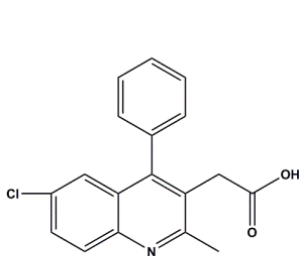

BI-A (6)

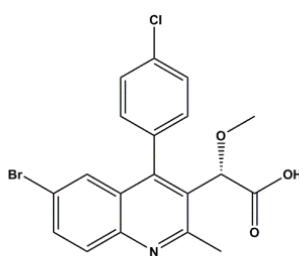

BI-1001 (7)

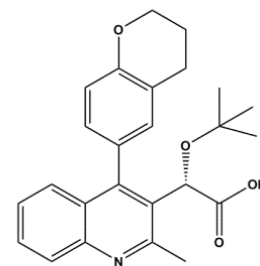

BI-D (8)

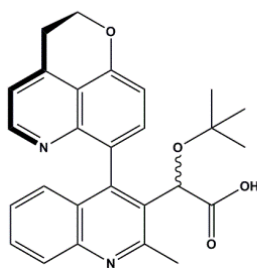

BI 224436 (9)

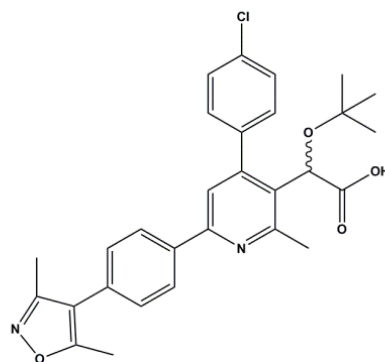

BI 224436 derived compound 20 (10)

Figure 4

Figure 4, LEDGINS and analogues. Shown are the compounds developed by KU Leuven (1-5) and BI (6-10).

Table 2, Antiviral activity of the displayed compounds

Target	Compound #	Compound name	EC ₅₀ (μM)	EC ₅₀ measurement	
LEDGF/p75 binding pocket on HIV-Integrase	1	C1	/	Not determined <i>in cellulo</i>	
	2	C3	41.9±1.1	HIV _{IIIB} in a MT4 -MTT assay ^{74, 78}	
	3	CX05168	2.35 ± 0.28		
	4	CX05045	0.76 ± 0.08		
	5	CX014442	0.069 ± 0.003		
		6	BI A	> 40	HIV _{HXB2} in C8166 LTRIuc cells ^{80a}
		7	BI-1001	0.99	
		8	BI-D	0.051 ± 0.031	HIV _{NL4.3} in C8166 LTRIuc cells ⁸¹
		9	BI224436	0.0072 - 0.015	
		10	BI224436 derived compound 20	0.0065 - 0.810	
ATP site of CDK9	11	Flavoperidol	0.006-0.0125	NL4.3 in Jurkats ²⁵	
	12	Roscovitine	0.36	Upon TNFα/PMA stimulation of OM10.1s 5 days post infection ^{28, 87}	
	13	Compound 37	4.0		
	14	CR8#13	<0.010	HIV _{IIIB} in MT-4s ⁸⁸	
	15	Compound 93	0.142		
	16	Indirubin-3'-monoxim	0.5-2	HIV _{ADA} and HIV _{IIIB} in PBMCs ^{27a}	
Tat-CDK9 interface (CDK9)	17	F07	~0.6	In HLM-1 cells transfected with Tat ²⁹	
	18	F07#13	0.12		
Tat-Cyclin-T1 interface	19	C1	4.2	Upon TNFα stimulation of OM10.1s 5 days post infection ³⁰ *HIV _{IIIB} in PBMCs	
	20	C2	4.8		
	21	C3	0.617 ± 0.011 0.0097*		
Vif/APOBEC3G stability	22	RN-18	4.5-10*	HIV _{LA-1} in H9s ¹⁷⁻¹⁸ or * in CEM cells ¹⁷	
	23	RN-18 analogue 5d	5.9		
	24	RN-18 analogue 40j	2.8		
	25	RN-18 analogue 17	1		
APOBEC3G degradation	26	IMB-26	0.017		
	27	IMB-35	0.017		
Vif-ElonginC interface	28	VEC-5	24.48	NL4.3, produced in 293T-cells expressing APOBEC3G, in MAGI-CCR5s ⁸⁹	
Vif-APOBEC3G interface	29	N.41	8.4-22.6	or HIV _{Bal} on PBMCs ¹⁹	

^a finished a clinical phase I trial

LEDGINs also affect late stage HIV replication through stimulation of IN multimerization leading to defective viral particles displaying a nucleoprotein complex outside the capsid cone^{83b, 85b, 90}. These immature particles show a defect in RT activity and nuclear import during the next infection round. Moreover, LEDGINs were shown to interact with IN

as a part of the Pol precursor and induce oligomerization [118].

Although potencies obtained in experiments conducted at various stages of HIV replication cannot be directly compared, LEDGINs tend to show a higher potency for impairment of the late stages of HIV replication compared to

the early stages^{83a, b, 90}. This finding implies that during the early phase of HIV replication LEDGINs have to compete with the endogenously present LEDGF/p75 and that potency will depend on the LEDGF/p75 levels in the infected cell. Compared to the cellular levels these levels will be much lower in viral particles during the late stages of infection⁹¹. This idea is corroborated by the fact that the potency of LEDGINs during early stages increases when LEDGF/p75 is depleted whereas the potency of LEDGINs during late stages is similar for viruses produced in wild type or LEDGF/p75-depleted cells^{61d, 91-92}.

3.5. Conclusion

In conclusion, LEDGINs form a promising class of compounds for further drug development. As LEDGINs can be combined with most clinically approved HIV drugs^{78, 80b}, they might become an integral part of cART in the future.

4. TARGETING THE TAT-P-TEFb INTERACTION

The HIV-1 Transactivator of transcription (Tat) is an 86-101 amino acid protein (**Figure 5A**). It contains a conserved activation domain (AD) and a nuclear localisation signal (NLS) also responsible for RNA binding (**Figure 5A**). In absence of binding partners it has no pronounced secondary structure elements⁹³. Tat interacts with the transactivation responsive (TAR) RNA of HIV and the cellular positive transcription elongation factor (P-TEFb) complex in order to promote efficient elongation of HIV transcripts^{5a, 94}. As this complex is key for efficient HIV transcription, targeting the P-TEFb-Tat interaction might form an interesting therapeutic approach.

4.1. P-TEFb promotes HIV transcriptional elongation

Tat-mediated recruitment of the P-TEFb complex to the TAR region promotes viral transcription elongation through P-TEFb-dependent phosphorylation of S2 and S5 in the hepta-repeats of the C-terminal domain of RNA polymerase II^{5a, 94-95}. P-TEFb is a Cyclin-dependent kinase, which embodies Cyclin-dependent kinase 9 (CDK9) and a Cyclin, in case of HIV infection Cyclin-T1 (CycT1)^{94a} (structure reviewed in⁹⁶). Apart from recruiting P-TEFb to the vRNA, Tat also stimulates the P-TEFb kinase activity and changes its substrate specificity⁹⁷. Additionally, Tat is able to release P-TEFb from its regulator 7SK snRNP, keeping it in an inactive form through its interaction with HEXIM1⁹⁸. CDK9 is a 372 amino-acid member of the cyclin-dependent kinase family, which are key cell cycle regulators. CDK9 encloses a kinase domain, including the T-loop which is able to bind Tat (**Figure 5A**). CDK9 forms a complex with Cyclin K or Cyclin T. Cyclin T is a member of the conserved cyclin C subfamily and exists in 3 different forms: CycT1, Cyclin-T2a and Cyclin-T2b. CycT1, which can interact with Tat, is a 726 amino acid protein which contains an N-terminal cyclin like domain (CLD) (**Figure 5A**).

4.2. Tat-P-TEFb interaction

Truncations and mutational analysis revealed that CycT1 is able to interact with TAR and Tat through a minimal binding domain, a region called the Tat/TAR recognition motif (TRM), which comprises amino acids 250-262 (**Figure 5A**)⁹⁹. In particular N250, R259 and C261 were found to be crucial for Tat binding. The crystal structure of Tat complexed with P-TEFb (PDB ID 3MIA)¹⁰⁰ revealed that Tat binds to both the CDK9 and the CycT1 units (**Figure 5B**). Tat binds to a groove at the heterodimer interface, which leads to a more stable and active P-TEFb complex (**Figure 5B**). The Tat acidic/proline-rich region forms an extended loop conformation, containing 2 type II β -turns and one type II' β -turn (**Figure 5A, 5B**). The cysteine-rich and core regions contain a random coil, two helices, a tail and two bound zinc ions (**Figure 5A, 5B**). The second zinc ion is coordinated by 3 cysteines of Tat and one of CycT1, C261 (**Figure 5A, 5C**). In addition, Tat contains a hydrophobic patch binding to the hydrophobic surface of CycT1. Furthermore Tat forms direct and water-mediated hydrogen bonds with CDK9 and CycT1, stabilizing its conformation. CDK9 interacts with Tat through its T-loop region (**Figure 5A, Figure 5B**). Upon binding with Tat, CDK9 undergoes conformational changes, explaining why Tat bound P-TEFb is able to not only phosphorylate S2 in the RNA Polymerase II CTD, but also S5.

4.3. Targeting the P-TEFb-Tat interaction

Until now, antiretroviral therapy does not contain compounds targeting HIV transactivation. Moreover, compounds interfering with the release of viral particles from HIV reservoirs are unavailable, which makes Tat-P-TEFb an attractive target in order to reduce transactivation of HIV replication of already infected cells (also recently reviewed in¹⁰¹). Furthermore, Tat seems to be the main determinant to control latency¹⁰². Hence, compounds targeting Tat-P-TEFb could potentially impair 1.) reactivation from latently infected cells, 2.) expansion/replenishment of the latent reservoir. 3.) basal HIV replication in patients under current cART therapy, which is believed to play a role in co-morbidities (as also stated in¹⁰¹). Reducing the latent reservoir could be an alternative strategy for the 'purge and kill' strategy put forward the last decade¹⁰³. Hereby the latent reservoir is reactivated in order to be targeted by cART and to be killed by the host immune system. HIV transactivation inhibitors provide a valuable alternative.

In order to impair HIV transcription elongation, different strategies can be envisaged: One may target either 1.) CDK9 kinase activity, 2.) Tat-CDK9 interaction, 3.) Tat- CycT1-interaction, or 4.) Tat itself and its interactions with TAR (not discussed in this review). Specific impairment of HIV transcription will be challenging, as by inhibiting P-TEFb also general cellular transcription processes might be affected. However, the observation that Tat induces conformational changes in CDK9 implies that the design of specific Tat-P-TEFb inhibitors can be undertaken¹⁰⁰.

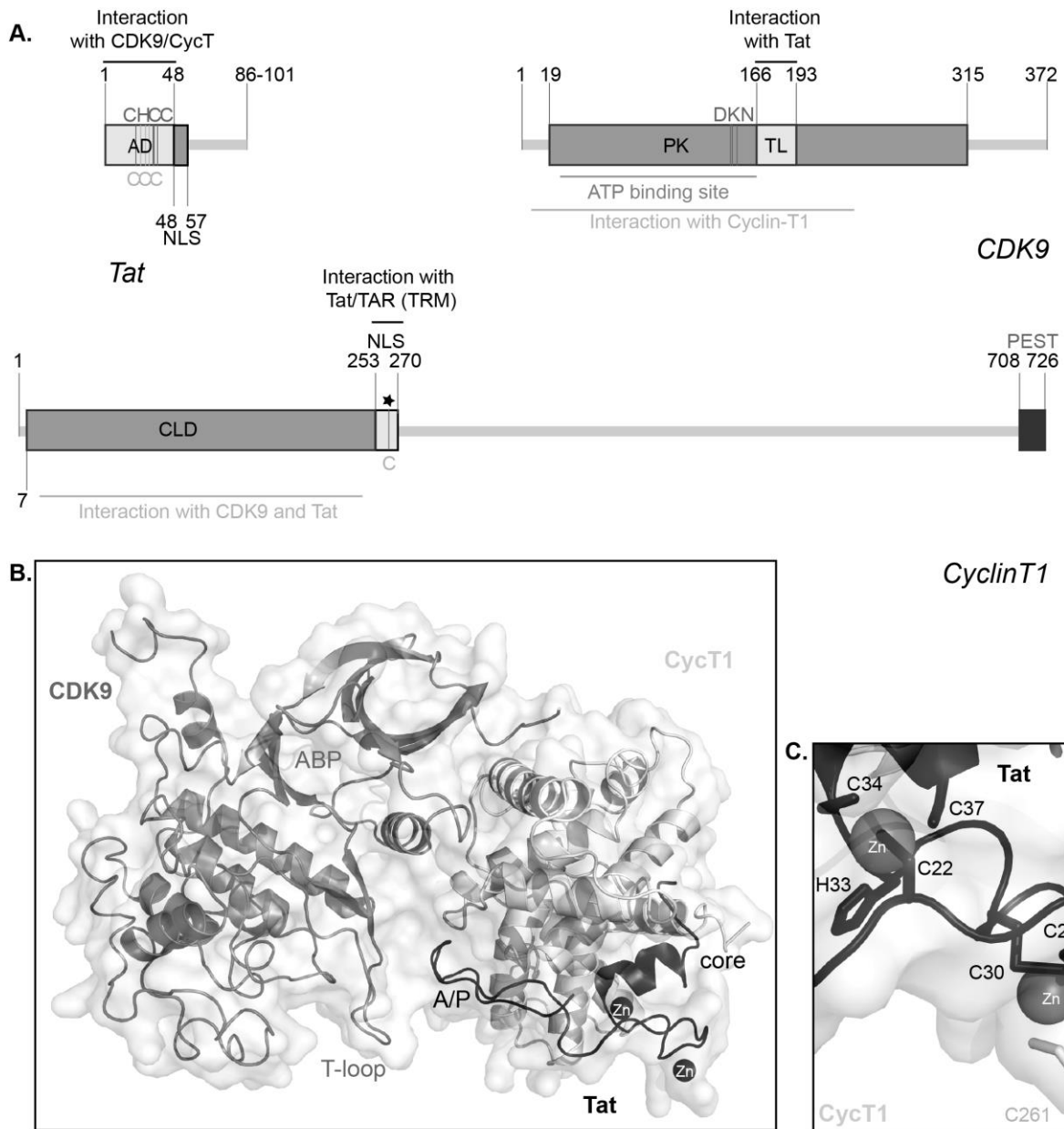

Figure 5 Tat binding to the P-TEFb complex

Zinc binding by Tat and Cyclin-T1

Figure 5, The Tat-pTEFb complex. **A.** Schematic representation of Tat and PTEF-b. Tat comprises an activation domain (AD), consisting of an acidic/proline-rich region (1-20), a cysteine-rich/zinc finger (CHCC and CCC) containing region (20-40), a core domain (40-48), and a nuclear localisation signal (NLS). The NLS domain is also responsible for RNA-binding. This region is followed by a glutamine-rich region (57-72). CDK9 contains a protein kinase domain, with the ATP binding site, a Serine/Threonine protein kinases active-site signature ([LIVMFYC]-x-[HY]-x-D-[LIVMFY]-K-x(2)-N-[LIVMFYCT]) and the activation loop (T-loop (TL)). Cyclin-T1 contains a Cyclin like domain (CLD), a nuclear localisation signal (NLS) and a PEST sequence, which is a signal for rapid cellular proteolysis. The Tat/TAR recognition motif is shown (TRM). The C261 amino acid which interacts with Tat through a Zinc bridge is marked with a *star*. **B.** Structure of the Tat-P-TEFb complex. Amino acids 1-49 from Tat, corresponding to the Tat activation domain, are solved in this structure. Tat binds with its acidic/proline rich (A/P) region to the T-loop of CDK9. Also the ATP binding pocket (ABP) of CDK9 is shown. Tat binds in extended conformation to Cyclin-T1 (CycT1), through hydrophobic interactions and salt bridges. Tat contains 2 zinc fingers, the second one forms a zinc mediated bridge with CycT1 C261. **C.** Detail of zinc binding by Tat and CycT1. Figures **B**, **C** were based on PDB ID 3MIA and adapted with pymol software⁷⁵.

Knock-down studies, mutational analysis, use of a Tat, CDK9 and CycT1 dominant negative form, Tat fusion proteins and the availability of a crystal structure of the Tat – P-TEFb complex and the EIAV Tat-TAR complex, validated the Tat-P-TEFb(-TAR) complex as a druggable target^{99b, 100, 104}. Furthermore peptides and cellular proteins which are able to compete with Tat for -P-TEFb binding have been described¹⁰⁵.

4.3.1 CDK9 kinase inhibitors

Around the late '90s, the first kinase inhibitors targeting the Tat-P-TEFb complex were discovered^{25-26, 106}. Although more than a decade of research passed by, nowadays none of these inhibitors is enrolled in clinical trials for HIV treatment since specific inhibition of the kinase activity of CDK9 without impairing the downstream cellular processes mediated by CDK9, has not been achieved so far.

4.3.1.1 CDK9 kinase activity inhibitors or ATP site antagonists

The most common strategy to impair the activity of a kinase is to block the ATP binding pocket with a small molecule. ATP site antagonists, including flavoperidol (**11**) and roscovitine (**12**), are able to block CDK9 kinase activity and as such, HIV replication²⁵⁻²⁶ (**Figure 6, table 2**). Flavoperidol (**11**) inhibits general mRNA production and is therefore under clinical development for the treatment of chronic lymphocytic leukemia and solid tumors (alvocidib)⁷. Roscovitine (**12**) (seliciclib) is also evaluated for treatment of different cancers and Cushing disease⁷. Due to the high similarity of the ATP binding pockets, development of more specific CDK9 inhibitors remains a challenge. Although some efforts to develop less toxic and more specific flavoperidol analogues were undertaken, interference with general cellular processes remained an issue¹⁰⁷. Most progress in obtaining more specific CDK9 inhibitors has been achieved by a recent *in silico* study starting from flavoperidol in complex with P-TEFb, where a new class of non-toxic anti-CDK9 compounds based on the 2-phenylquinazolinone scaffold was identified²⁸. The most potent compound of this study was compound 37 (**13**) (2-(4-aminophenyl)-7-chloroquinazolin-4(3H)-one), which affected HIV transcription in OM-10.1 cells upon phorbol myristate acetate (PMA) stimulation with an EC₅₀ of 4.0 μM and an SI of 86. OM-10.1 cells contain a single integrated provirus and show a minimal constitutive HIV-1 production. Upon TNF-α treatment, HIV transcription increases 30-1000 fold 24-72 hours post treatment in these cell lines. Also analogues of roscovitine with enhanced safety profile have been described, for example CR8#13 (**14**), able to inhibit HIV replication in OM10.1 cells with an EC₅₀ of less than 10 nM^{87b, 108}.

Other specific CDK9 kinase inhibitors have been reported, although they still show some off target effects and act on general transcription processes. For example, the phosphonic compound 93 (**15**) from Nemeth *et al.* interacts mainly with the CDK9-CycT1 complex, and not with free CDK9;

however, it does not provide protection of MT-4 cells against HIV infection⁸⁸. Furthermore indirubin-3'-monoxim (**16**), derived from a Chinese anti-leukemia herbal medicine, is a CDK9 inhibitor which impairs HIV replication in PBMCs and macrophages at non-toxic concentrations^{27a}. Recently, evaluation in a humanized mouse model showed activity against a multidrug resistant HIV strain, but more extensive toxicological and pharmacokinetic evaluation is required^{27b}.

Overall, targeting the kinase activity of CDK9 using compounds targeting the CDK9 ATP pocket as a therapeutic strategy for HIV treatment is not yet feasible, as the balance between antiviral activity and cytotoxicity is a thin line due to non-specific binding to other kinases and the interference with cellular processes mediated by CDK9. To circumvent these problems future drug development could focus on Tat-P-TEF-b kinase inhibitors, as binding of Tat changes the conformation of the CDK9 and so, the substrate specificity.

4.3.2 Tat-CDK9 interaction inhibitors

Another strategy aims at targeting the CDK9-CyclinT1 interface which is occupied by Tat, in particular the Tat binding interface on CDK9. Tat based peptides targeting the pocket of the CDK-Cyclin complex, binding to CDK2 and CDK9, were used to obtain a pharmacophore model in order to select small-molecule ligands occupying the CDK-Cyclin interface²⁹. CDK2 is similar to CDK9 and the Tat-based peptides were found to bind both molecules. High-throughput docking of compounds to the binding pocket of CDK9 and further evaluation in HIV-1 infected cells, led to the discovery of F07 (**17**), a 5-Ar-3-oxymethyl-Ar-1,2-oxazole compound (**Figure 6, table 2**). Specificity of the inhibition of Tat transactivation was further evaluated using TZM-bl cells, containing a LTR-luciferase reporter gene, and HLM1, containing a Tat-defective provirus that can be complemented with a Tat expression construct. A next generation compound (F07#13) (**18**), a result from SAR optimization, showed activity against multiple HIV strains in PBMCs. Well known genes regulated by CDK9 showed no alteration in expression in HIV infected PBMCs. Furthermore, an *in vivo* evaluation of F07#13 (**18**) in a humanized mouse model demonstrated effective inhibition of HIV replication and no toxicity upon 3 months after initial treatment. Docking revealed that F07#13 (**18**) preferentially targeted the Tat interface pocket on CDK9 in presence of Tat. This result was in line with the observation that CDK9 could only be dissociated from the HIV transcription complex in an *in vitro* assay when Tat was present.

In conclusion, this compound has an inhibitory mechanism different from that of ATP analogues, and may dissociate CDK9 from Cyclin *in vivo*. Some additional evaluation for the specific binding to the CDK9-CycT1-Tat complex seems required, as the binding of other Cyclin dependent kinases was not evaluated. Furthermore, a crystal of the P-TEFb complex including the compound would be of great help for further optimization.

**Figure 6**

Figure 6, Tat-P-TEFb inhibitors. Shown are compounds binding to the CDK9 ATP pocket (11-16) and compounds developed by Van Duyne *et al.* (17-18) and Hashamaki *et al.* (19-21).

4.3.3 Tat-Cyclin-T1 inhibitors

Compounds targeting the TRM of CycT1 were described by Hamasakii *et al.* in 2012³⁰ (Figure 6, table 2). A large compound database was screened *in silico* against a model of the CycT1 TRM based on the crystal structures of the EIAV Tat/TAR RNA complex (PDB ID 2W2H) and the human CDK9/CycT1/HIV-1 Tat complex (PDB ID 3MIA, described above). Compounds C1 (19) and C2 (20) inhibited HIV-1 replication in chronically infected OM-10.1 cells, upon TNF- α stimulation, with an EC₅₀ of 4.2 and 4.8 μ M, respectively. A C1 and C2 derivative, C3 (21), was able to impede HIV-1 replication with an EC₅₀ of 617 \pm 11 nM in OM-10.1 cells. Additionally, HIV_{III}B replication in CEM, MOLT-4 and PBMCs was inhibited by C3 (21) with a potency of respectively 19.9 \pm 3.4 nM, 17.9 \pm 6.6 nM and 9.6 nM. Moreover, the compound seemed well tolerated in PBMCs with an SI of 708. In conclusion, these compounds seem promising for further development, and form a proof of concept for Tat-CycT1 inhibitors. However, the difference between EC₅₀'s in OM-10.1 and PBMCs could point towards an additional inhibitory effect, and so, further research is necessary.

4.3.3 Conclusion

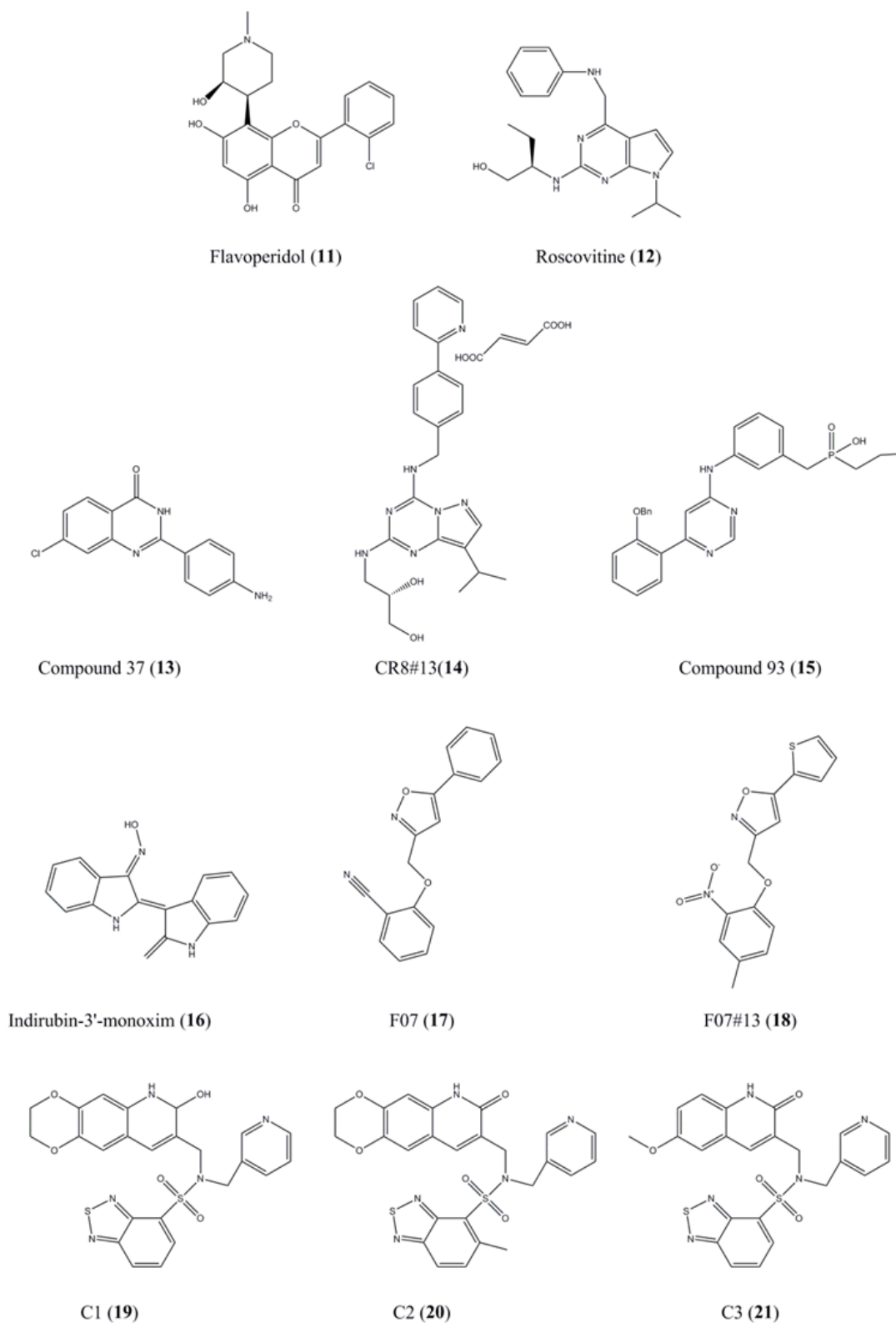
Compounds inhibiting the Tat-P-TEFb complex could be a valuable addition to cART. In particular the fact that no HIV transcription activation inhibitors are available yet, makes the Tat-P-TEFb complex a target of great interest. ATP site antagonists targeting the CDK9 ATP pocket might not be the best option for now, as even compounds which would be completely selective for CDK9, could still interfere with downstream processes. Therefore the focus should be on specific inhibitors of the complex, targeting interactions between Tat, CDK9 and CycT1 or targeting the CDK9

pocket when CDK9 is in complex with Tat and CycT1.

5. TARGETING THE Vif-APOBEC3G INTERACTION

A3G-mediated restriction of retroviral replication is efficiently counteracted by HIV-1 Vif⁶⁰. It follows that inhibition of the Vif-A3G interaction can be considered an interesting potential antiviral target.

5.1. HIV-1 Vif, the Virus infectivity factor.

The 23 kDa Virus infectivity factor (Vif) resides mainly in the cytoplasm and is expressed from partially spliced mRNA in a Rev-dependent way¹⁰⁹. Vif contains an N-terminal region which is responsible for RNA and A3F/G binding, a central HCCH zinc binding motif responsible for Cul5 interaction and a C-terminal region with a BC-like box, responsible for EloC binding and a multimerization domain (Figure 7) (reviewed in¹¹⁰). It is essential for HIV replication in primary lymphoid and myeloid cells, but not in several transformed T-cell lines, nor in non-lymphoid cell lines such as HeLa and HEK293T cells. It inhibits encapsidation of A3F/G through targeting it for proteosomal degradation after recruiting an E3 ubiquitin ligase complex, which consists of Cullin5 (Cul5), ElonginB (EloB), Elongin C (EloC), CBF β and RING-box protein 2 (RBX2)¹¹¹. Cul5, EloB, EloC, CBF β and nearly full length Vif have been co-crystallized in 2014, which could lead to more insights concerning the interaction between Vif and this complex. Vif also interferes with the A3F/G antiviral activity through interfering with its packaging and expression through different pathways¹¹². Furthermore Vif possesses RNA binding and chaperone properties¹¹³. Transdominant Vif mutants have been described, which open the door for strategies targeting Vif¹¹⁴.

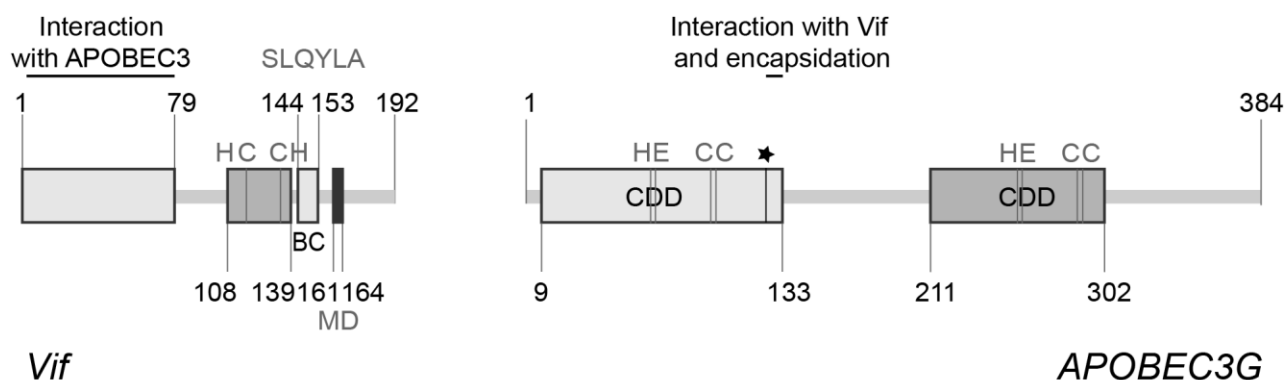

Figure 7

Figure 7, Vif and APOBEC3G domains A schematic representation of the Vif and APOBEC3G domains is shown. The Vif N-terminus interacts with APOBEC3F, APOBEC3G and RNA. Vif contains a Zinc binding motif (HCCH) responsible for Cullin5 binding, a BC-box-like motif (BC) binding to ElonginC and a multimerization domain (MD). APOBEC3G contains 2 cytidine deaminase zinc binding domains (CCD), of which only the first one is catalytically active. The D128 amino acid responsible for Vif binding is marked by a star.

5.2. APOBEC3G inhibits HIV replication through enhancing innate immunity

In 2002 Sheehy *et al.* discovered that APOBEC3G inhibits HIV replication when Vif is not present⁶⁰. Since then, different groups unravelled its role in HIV replication (reviewed in¹¹⁰). A3G, a 384 amino-acid protein, is the most widely studied enzyme of the Apolipoprotein B mRNA-editing enzyme catalytic polypeptide-like 3 family (APOBEC3 (A3)), a family of polynucleotide cytidine deaminases (reviewed in¹¹⁵). The protein plays a role in innate immunity by restricting viruses with ssDNA intermediates. Although A3G is counteracted by Vif, patients with high levels of A3G are less likely to become infected with HIV or to progress to AIDS¹¹⁶.

A3G mainly, but not solely, acts through its deoxycytidine deamination activity which results in hypermutated and inactivated viral genomes (recently reviewed by¹¹⁰). In the absence of Vif, it is incorporated into viral particles through its interaction with the vRNA. Post entry, A3G deaminates deoxycytidines leading to deoxyuridines in the ss (-) DNA during reverse transcription¹¹⁷. Also other A3 proteins play a role in hypermutating vRNA, especially A3F has been validated as a restriction factor for HIV replication (reviewed in¹¹⁰). A3G contains two Zinc coordinating catalytic domains, of which one is catalytically active and a linker region containing residues responsible for its RNA-interaction, encapsidation and oligomerization (Figure 7).

5.3. The Vif -APOBEC3G interaction

Different efforts have been undertaken to unravel the interaction between Vif and A3G (reviewed in¹¹⁰). The Vif Y69 and L72 amino-acids are found critical for A3G-binding, the DPD-motif (residues 128-130) on A3G for Vif binding. A D128K mutation in A3G renders the protein resistant for Vif binding. A recent overview of A3 interacting motifs is given in¹¹⁸. Because no structural data from a co-crystal of Vif and A3G are available, it cannot be excluded that mutations in those domains result in conformational changes that interfere indirectly with the protein-protein interaction, although the described interactions seem to be exposed in the Vif – E3 ubiquitin ligase complex co-crystal.

5.4. Targeting the Vif-APOBEC3G interaction

Mutagenesis studies and the development of peptides inhibiting Vif multimerization or targeting the Vif-A3G interaction demonstrated that targeting the Vif-A3G interaction could be a valuable approach^{110,119}. Although Vif is critical for the infectivity of virus *in vivo*, when targeting the Vif-A3G interaction, some considerations need to be taken into account. First, an incomplete inhibition of Vif-activity could provide viruses with a selective advantage, as natural Vif polymorphisms with a partially defective Vif show accelerated DR development¹²⁰. Secondly, the impact of increasing A3G levels on cell proliferation and tumour formation has to be evaluated, as A3G levels are high in some tumour cells¹²¹. Third, no crystal structure of the

complex is available which makes drug discovery quite challenging.

In cellulo A3G-YFP Vif high throughput screens led to the discovery of 2 different classes of compounds: 1.) RN-18 (22) or N-(2-methoxyphenyl)-2-((4-nitrophenyl)thio)benzamide, described by Nathans *et al.* in 2008 and 2.) IMB-26 (26) and IMB-35 (27) described by Cen *et al.* in 2010¹⁷⁻¹⁸. More recently, VEC-5 (29) and N.41 (30) have been discovered, using an *in silico* and an *in vitro* approach, respectively^{19,89} (Figure 8, table 2).

5.4.1. RN-18 decreases Vif levels and increases APOBEC3G levels.

RN-18 (22) inhibits HIV-RT activity of the X4-tropic virus HIV-1_{LAI} in non-permissive A3G expressing CEM and H9 cells with an EC₅₀ of 4.5 μM, but not in permissive cell lines¹⁷. Upon adding RN-18 (22), Vif protein levels were down-regulated, while A3G (and A3C and A3F) levels were upregulated, both in cells and virions. A3G incorporation could only be restored in a Vif-dependent manner, as a virus lacking Vif was not able to restore A3G levels. Likewise, adding RN-18 (23) neither led to increased expression of the A3G D128K mutant in HIV-1 producer cells. According to the authors, increased A3G packaging in virions, induced by RN-18 (23), appeared not to be due to an inhibition of the general proteasome-mediated pathway, as evidenced by the fact that p21 levels, which are modulated by the proteasome, were not altered. Hence, other proteins degraded by the proteasome could be affected. No toxicity was observed up till 100 μM in H9 cells. SAR optimization of RN-18 has led to the discovery of compounds like 5d (23) and 40 j (24) by Ali *et al.* and to the water soluble compound 17 (25) by Mohammed *et al.*¹²², which could be interesting new leads for Vif-dependent HIV inhibitors¹²³. Although the results suggest that the effect of RN-18 (22) is Vif-dependent, no evidence has been shown that RN-18 (22) directly interrupts the interaction between Vif and A3G.

5.4.2. IMB-26 and IMB-28, inhibitors of A3G degradation

IMB-26 (26) and IMB-28 (27) were identified as specific inhibitors of the degradation of A3G by Vif in an *in cellulo* A3G-YFP high throughput screen¹⁸. They bind directly to A3G, as studied with surface plasmon resonance (SPR) analysis, and abolish the Vif-A3G interaction in co-IP. They hamper HIV replication in non-permissive H9 cells with an EC₅₀ of 17 nM. The compounds are considered as safe, with a therapeutic index >200 *in vitro* and a LD₅₀ >1000 mg/kg for IMB-26(26) in BALB/c mice. Docking of these compounds into a A3G model based on crystal structures of APOBEC2 and the catalytic domain structure of A3G, revealed that IMB-26(26) and IMB-28 (27) likely interact with the A3G Y22 amino-acid through a π-π interaction, and with F17, W94 and A121 through hydrophobic interactions¹²⁴. These amino-acids are predicted to mediate A3G oligomerization and would play a role in the interaction with Vif¹²⁵.

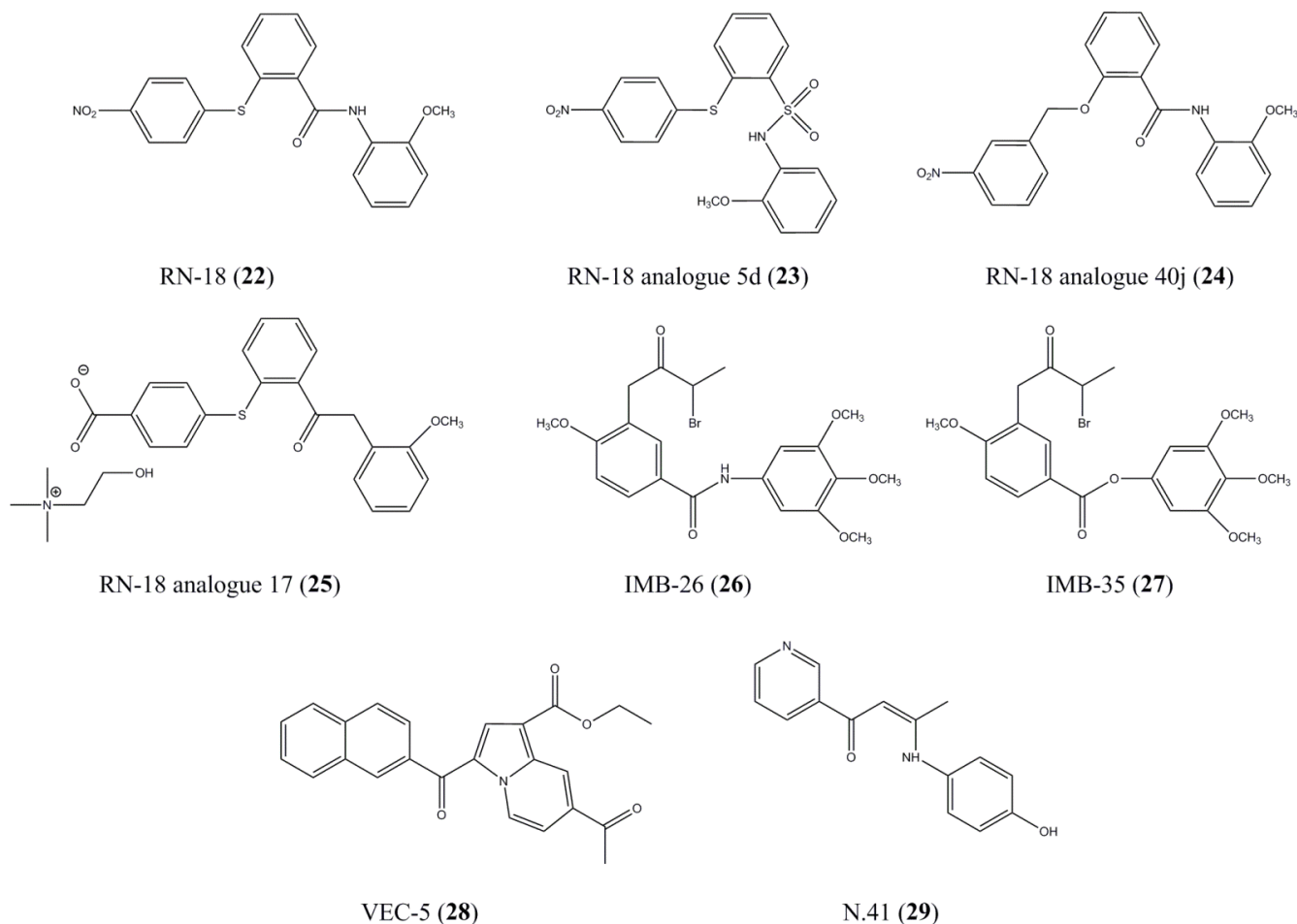

Figure 8

Figure 8, Vif-APOBEC3G inhibitors. Shown are the compounds RN-18 and analogues (22-25), IMB-26 and IMB-35 (26-27), VEC-5 (28) and N.41 (29).

5.4.3. VEC-5, a Vif-ElonginC interaction inhibitor

VEC-5 (28), a compound discovered using a virtual screening approach based on a Vif-EloB/C homology model, disrupts the interaction between Vif and EloC (a part from the E3 ubiquitin ligase complex), as studied by co-IP⁸⁹. VEC-5 (28) hampered HIV-1_{NL4.3} infectivity with an EC₅₀ of 24.48 μM (95% CI: 20.34 to 29.48 μM) when virus was produced in 293T cells expressing A3G. A3G and A3F levels in producer cells and virus particles increased upon addition of VEC-5 when Vif was co-expressed. Also Vif levels were increased upon addition of VEC-5 (28). VEC-5 was initially predicted to bind to the Vif-binding pocket on EloC. Other docking studies classified it as a Vif-binder interfering with the Vif-A3G binding¹²⁶. Concerns for Vif-EloC interaction blockers include a lack of specificity, as the BC-box for EloC binding is a conserved structure. Hence,

the recently published crystal structure might be used as a base for specific drug design.

5.4.4 N.41, a direct Vif-A3G interaction inhibitor

Recently, a new compound, N.41 (29), was described as an inhibitor of the Vif-A3G interaction¹⁹. This lead compound was discovered using a TR-FRET-based screen with purified Glutathione-S-transferase tagged Vif and the A3G₁₁₀₋₁₄₈ peptide and the *in cellulo* screen described above. N.41 inhibited the Vif-A3G₁₁₀₋₁₄₈ interaction for 89% when used at 6.25 μM. Inhibition of HIV-1_{Bal} replication occurred at an IC₅₀ of 8.4-22.6 μM in PBMCs. HIV replication was hampered when virus was produced on A3G expressing cells, but surprisingly, when produced on A3F expressing cells HIV replication was increased. This suggests that evaluating Vif-A3G inhibiting compounds as antivirals

should include thorough testing of their effects on other A3 family members.

5.4. Conclusion

In conclusion, compounds targeting the Vif-A3G interaction are still in an early drug discovery stage. The availability of a co-crystal structure would be of great help to further spur drug development. RN-18 (**23**), IMB-26 (**27**) and IMB-28 (**28**) were mainly evaluated *in cellulo*, so their effect on HIV replication can be due to indirect down-regulation of Vif or up-regulation of A3G. Only the N.41 (**29**) compound was evaluated *in vitro* at the protein level, which suggests that this compound is a direct inhibitor of the Vif-A3G interaction. As incomplete inhibition of Vif could lead to a development of viruses with a selective advantage¹²⁰, thorough pre-clinical evaluation of Vif-A3G compounds will be necessary. Also the effect on other members of the A3 family should be studied. Additionally, it is unclear if compounds targeting the Vif-A3G interaction will show sufficient antiviral activity *in vivo*.

6. GENERAL DISCUSSION AND CONCLUSION

The exponential increase of studies on virus-host interactions only started about a decade ago. As such it is not surprising that, while a lot of cellular interactions have been described, the way to the clinic is still long; however, significant progress has already been made and new cofactors are still discovered on a regular base. In particular, the approval of maraviroc in 2007 as part of antiretroviral therapy provided a proof-of-concept for cofactor targeting³. In addition, a number of other HIV entry inhibitors made it into clinical trials (**table 1**), among them other CCR5-antagonists and attachment inhibitors. In particular, fostemsavir (BMS-663068), which binds to gp-120 and prevents attachment to CD4, is a promising candidate for antiretroviral therapy¹¹.

LEDGINS are another good example of how blue sky research on HIV replication can lead to the development of potent small molecules. First clinical trial results for LEDGINS were reported in 2014⁷. Remaining pharmacokinetic problems with the BI224436 compound (**9**) with enterohepatic recirculation were solved with a scaffold hopping approach leading to the development of a new series of compounds with an improved clearance profile⁸¹. As LEDGINS show additivity or synergy in combination with most FDA approved antiretrovirals, they could be part of cART. Although it is still debated whether these compounds mainly act through LEDGF/p75 displacement from HIV-1 IN or IN multimerization, their discovery is intimately linked to the discovery of LEDGF/p75 as an IN interaction partner in 2003⁶³. Together with (co-)receptor inhibitors, LEDGINS prove the utility of identifying novel HIV cofactors.

Most other inhibitors targeting cofactors or cofactor-HIV-1 protein interactions are still in a stage of early drug development (**table 1**). This is the case for Tat-P-TEFb inhibitors. Targeting the Tat-P-TEFb interaction would be of great interest as no transactivation inhibitors of HIV-1 replication are available yet, so these compounds would

form a new class of antiretrovirals. Additionally, the observation that inhibitors of this interaction would be able to hamper HIV-1 production from already infected cells could be of great advantage as no other compounds are able to impede low basal HIV production from chronically infected cells or reactivation from latently infected cells.

Although CDK9 was discovered as a Tat-binding partner in 1995 (as TAK or Tat associated kinase), no compounds targeting CDK9 were evaluated in clinical trials during the last decade^{5a}. Lack of specificity of most kinase inhibitors and interference with downstream cellular processes are mainly responsible for this slow progress. In addition, the assays used to detect these compounds were based on Tat-transactivation of a reporter gene, which could be affected by multiple processes. Although these issues made the development of Tat-P-TEFb inhibitors quite challenging, some progress has been made: 1.) A crystal complex of Tat with P-TEFb revealed conformational changes upon Tat binding of the ATP binding site, opening the door for specific CDK9 kinase inhibitors¹⁰⁰ 2.) Recent *in vivo* validation in a humanized mice model of compounds targeting the Tat-CDK9 interaction is promising, although further optimization and evaluation is necessary²⁹ 3.) Also small chemical molecules targeting the Tat-CycT1 interaction have been described³⁰. Overall, with respect to Tat-P-TEFb inhibitors, future focus should be on the complex, and not on the separate proteins.

The compounds targeting the Vif-A3G interaction are also in an early drug discovery stage. Despite the fact that some compounds which showed potent antiviral activity *in vitro* have been described, no *in vivo* studies have been published so far. So, the question remains if impairing A3G degradation by small chemical molecules would be sufficient to hamper HIV replication in *in vivo* conditions. Likewise, the effects of A3G-Vif interaction inhibitors on other A3 family members should be systematically studied. Additionally, the development of inhibitors directly targeting Vif-A3G remains challenging as 1.) No crystal structure of the complex is available 2.) No protocol for purification of the full length proteins in large amounts is available 3.) Vif should be completely inhibited, as incomplete inhibition of Vif could lead to the production of viruses with a selective advantage¹²⁰. Nevertheless, inhibition of the Vif-A3G interaction can be seen as a boost of the innate immune system, which would add a new twist to antiretroviral therapy.

In conclusion, the compounds discussed in this review demonstrate the importance of thorough validation of cofactors and their interaction with HIV proteins as antiviral targets. The obtained clinical successes validate further investments in HIV cofactor identification, validation and drug development. As only a fraction of cofactors is known by now, many opportunities for new antiretroviral therapies remain.

LIST OF ABBREVIATIONS

A3 or APOBEC3	Apolipoprotein B mRNA-editing enzyme catalytic polypeptide-like 3 family	SEC-MALS	SEC-multi-angle static light scattering
AD	Activation domain	SI	Selectivity index
ALIX	ALG-2-interacting protein X	siRNA	Small interfering RNA
ATP	Adenosine triphosphate	SIV	Simian immunodeficiency virus
CA	Capsid	Tat	Transactivator of transcription
cART	Combined Anti-Retroviral Therapy	TAR	Transactivation response element
CC ₅₀	half maximal cytotoxic concentration	TNF- α	Tumor necrosis factor α
CCD	Catalytic core domain	TRM	Tat/TAR recognition motif
CCR5	C-C chemokine type 5 receptor	TSG101	Tumor susceptibility gene 101 protein
CD4	Cluster of differentiation 4	RT	Reverse transcriptase
CDK2	Cyclin dependent kinase 2	Tat	Trans-activator of transcription
CDK9	Cyclin dependent kinase 9	TRIM5 α	Tripartite motif-containing protein 5
cDNA	Copy deoxyribonucleic acid	vDNA	Viral deoxyribonucleic acid
Co-IP	Co-immunoprecipitation	Vif	Virus infectivity factor
CRM1	Chromosome region maintenance 1	Vpr	Viral protein R
CTD	C-terminal domain	Vpu	Viral protein Unique
Cul5	Cullin 5	vDNA	Viral DNA
CXCR4	C-X-C chemokine receptor type 4	vRNA	Viral ribonucleic acid
CycT1	Cyclin-T1		
CypA	Cyclophylin A		
CPSF6	Cleavage and polyadenylation specific factor 6		
DDX3	Dead-box Helicase 3		
DR	Drug resistance		
DSF	Differential scanning fluorimetry		
EC ₅₀	Half maximal effective concentration		
EloB/C	Elongin B/C		
ESCRT	Endosomal sorting complexes required for transport		
FRET	Förster resonance energy transfer		
Gp41	Envelope glycoprotein gp41		
Gp120	Envelope glycoprotein gp120		
HCK	Tyrosine protein kinase HCK		
HDGF	Hepatoma Derived Growth Factor		
HIV	Human Immunodeficiency Virus		
HTRF	Homogeneous Time Resolved Fluorescence		
IC ₅₀	Half maximal inhibitory concentration		
IN	Integrase		
KD	Knock-down		
KO	Knock-out		
LEDGF/p75	Lens epithelium growth factor		
Nef	Negative regulatory factor		
NLS	Nuclear localization signal		
NTD	N-terminal domain		
PIC	Pre-Integration Complex		
PMA	phorbol myristate acetate		
P-TEFb	Positive transcription elongation factor		
SAR	Structure activity relation		
SAXS	Small-angle X-ray scattering		
SEC	Size exclusion chromatography		

CONFLICT OF INTEREST

KU Leuven has licensed intellectual property on LEDGINS to ViiV Healthcare for further development. The authors declare no further conflict of interest and have received no payment in the preparation of this manuscript.

ACKNOWLEDGEMENTS

Our research is supported by the Bijzonder Onderzoeksfonds (BOF) KU Leuven (OT-IDO), Belspo (BelVir), the Fonds voor Wetenschappelijk Onderzoek (FWO), the Agentschap voor Innovatie door Wetenschap en Technologie (IWT; SBO program), the European Commission Framework Program 7 (FP7 CHAARM), the ERANet EURECA. C. W. is a FWO fellow, F.C. is a fellow of the Flemish Industrial Research Fund (IOF).

REFERENCES

1. Iyidogan, P.; Anderson, K. S., Current perspectives on HIV-1 antiretroviral drug resistance. *Viruses* **2014**, *6* (10), 4095-139.
2. (a) Taltynov, O.; Desimmie, B. A.; Demeulemeester, J.; Christ, F.; Debyser, Z., Cellular cofactors of lentiviral integrase: from target validation to drug discovery. *Molecular biology international* **2012**, *2012*, 863405; (b) Debyser, Z.; Christ, F.; De Rijck, J.; Gijssbers, R., Host factors for retroviral integration site selection. *Trends in biochemical sciences* **2015**, *40* (2), 108-116; (c) Al-Mawsawi, L. Q.; Neamati, N., Blocking interactions between HIV-1 integrase and cellular cofactors: an emerging anti-retroviral strategy. *Trends in pharmacological sciences* **2007**, *28* (10), 526-35; (d) Busschots, K.; De Rijck, J.; Christ, F.; Debyser, Z., In search of small molecules

blocking interactions between HIV proteins and intracellular cofactors. *Molecular bioSystems* **2009**, *5* (1), 21-31.

3. Administration, U. S. F. a. D. Drugs@FDA. <http://www.accessdata.fda.gov/> (accessed March 8).

4. Maga, G.; Falchi, F.; Radi, M.; Botta, L.; Casaluze, G.; Bernardini, M.; Irannejad, H.; Manetti, F.; Garbelli, A.; Samuele, A.; Zanoli, S.; Este, J. A.; Gonzalez, E.; Zucca, E.; Paolucci, S.; Baldanti, F.; De Rijck, J.; Debyser, Z.; Botta, M., Toward the discovery of novel anti-HIV drugs. Second-generation inhibitors of the cellular ATPase DDX3 with improved anti-HIV activity: synthesis, structure-activity relationship analysis, cytotoxicity studies, and target validation. *ChemMedChem* **2011**, *6* (8), 1371-89.

5. (a) Herrmann, C. H.; Rice, A. P., Lentivirus Tat proteins specifically associate with a cellular protein kinase, TAK, that hyperphosphorylates the carboxyl-terminal domain of the large subunit of RNA polymerase II: candidate for a Tat cofactor. *Journal of virology* **1995**, *69* (3), 1612-20; (b) Saksela, K.; Cheng, G.; Baltimore, D., Proline-rich (PxxP) motifs in HIV-1 Nef bind to SH3 domains of a subset of Src kinases and are required for the enhanced growth of Nef+ viruses but not for down-regulation of CD4. *The EMBO journal* **1995**, *14* (3), 484-91.

6. Stuppel, P. A.; Batchelor, D. V.; Corless, M.; Dorr, P. K.; Ellis, D.; Fenwick, D. R.; Galan, S. R.; Jones, R. M.; Mason, H. J.; Middleton, D. S.; Perros, M.; Perruccio, F.; Platts, M. Y.; Pryde, D. C.; Rodrigues, D.; Smith, N. N.; Stephenson, P. T.; Webster, R.; Westby, M.; Wood, A., An imidazopiperidine series of CCR5 antagonists for the treatment of HIV: the discovery of N-[(1S)-1-(3-fluorophenyl)-3-[(3-endo)-3-(5-isobutyryl-2-methyl-4,5,6,7-tetrahydro-1H-imidazo[4,5-c]pyridin-1-yl)-8-azabicyclo[3.2.1]oct-8-yl]propyl}acetamide (PF-232798). *Journal of medicinal chemistry* **2011**, *54* (1), 67-77.

7. Health, U. S. N. I. o. clinicaltrials.gov. <https://clinicaltrials.gov/>.

8. Pett, S. L.; McCarthy, M. C.; Cooper, D. A.; MacRae, K.; Tendolkar, A.; Norris, R.; Strizki, J. M.; Williams, K. M.; Emery, S., A phase I study to explore the activity and safety of SCH532706, a small molecule chemokine receptor-5 antagonist in HIV type-1-infected patients. *Antiviral therapy* **2009**, *14* (1), 111-5.

9. Jenkinson, S.; Thomson, M.; McCoy, D.; Edelstein, M.; Danehower, S.; Lawrence, W.; Wheelan, P.; Spaltenstein, A.; Gudmundsson, K., Blockade of X4-tropic HIV-1 cellular entry by GSK812397, a potent noncompetitive CXCR4 receptor antagonist. *Antimicrobial agents and chemotherapy* **2010**, *54* (2), 817-24.

10. Vartanian, J. P., AMD-3100 (AnorMED). *IDrugs : the investigational drugs journal* **2000**, *3* (7), 811-6.

11. Thompson, M.; Lalezari, J.; Kaplan, R.; Pinedo, Y.; Sussman, P.; Cahn, P.; Stock, D.; Joshi, S.; Lataillade, M.; Hanna, G. In *Attachment Inhibitor Prodrug BMS-663068 in*

ARV-Experienced Subjects: Week 48 Analysis, CROI, Seattle, Seattle, 2015.

12. Singh, I. P.; Chauthe, S. K., Small molecule HIV entry inhibitors: Part II. Attachment and fusion inhibitors: 2004-2010. *Expert opinion on therapeutic patents* **2011**, *21* (3), 399-416.

13. Li, J.; Tan, Z.; Tang, S.; Hewlett, I.; Pang, R.; He, M.; He, S.; Tian, B.; Chen, K.; Yang, M., Discovery of dual inhibitors targeting both HIV-1 capsid and human cyclophilin A to inhibit the assembly and uncoating of the viral capsid. *Bioorganic & medicinal chemistry* **2009**, *17* (8), 3177-88.

14. Chen, K.; Tan, Z.; He, M.; Li, J.; Tang, S.; Hewlett, I.; Yu, F.; Jin, Y.; Yang, M., Structure-activity relationships (SAR) research of thiourea derivatives as dual inhibitors targeting both HIV-1 capsid and human cyclophilin A. *Chemical biology & drug design* **2010**, *76* (1), 25-33.

15. Tian, Y. S.; Verathamjamras, C.; Kawashita, N.; Okamoto, K.; Yasunaga, T.; Ikuta, K.; Kameoka, M.; Takagi, T., Discovery of novel low-molecular-weight HIV-1 inhibitors interacting with cyclophilin A using in silico screening and biological evaluations. *Journal of molecular modeling* **2013**, *19* (1), 465-75.

16. Chen, S.; Zhao, X.; Tan, J.; Lu, H.; Qi, Z.; Huang, Q.; Zeng, X.; Zhang, M.; Jiang, S.; Jiang, H.; Yu, L., Structure-based identification of small molecule compounds targeting cell cyclophilin A with anti-HIV-1 activity. *European journal of pharmacology* **2007**, *565* (1-3), 54-9.

17. Nathans, R.; Cao, H.; Sharova, N.; Ali, A.; Sharkey, M.; Stranska, R.; Stevenson, M.; Rana, T. M., Small-molecule inhibition of HIV-1 Vif. *Nature biotechnology* **2008**, *26* (10), 1187-92.

18. Cen, S.; Peng, Z. G.; Li, X. Y.; Li, Z. R.; Ma, J.; Wang, Y. M.; Fan, B.; You, X. F.; Wang, Y. P.; Liu, F.; Shao, R. G.; Zhao, L. X.; Yu, L.; Jiang, J. D., Small molecular compounds inhibit HIV-1 replication through specifically stabilizing APOBEC3G. *The Journal of biological chemistry* **2010**, *285* (22), 16546-52.

19. Pery, E.; Sheehy, A.; Nebane, N. M.; Brazier, A. J.; Misra, V.; Rajendran, K. S.; Buhlrlage, S. J.; Mankowski, M. K.; Rasmussen, L.; White, E. L.; Ptak, R. G.; Gabuzda, D., Identification of a novel HIV-1 inhibitor targeting Vif-dependent degradation of human APOBEC3G protein. *The Journal of biological chemistry* **2015**, *290* (16), 10504-17.

20. Demeulemeester, J.; Chaltin, P.; Marchand, A.; De Maeyer, M.; Debyser, Z.; Christ, F., LEDGINS, non-catalytic site inhibitors of HIV-1 integrase: a patent review (2006 - 2014). *Expert opinion on therapeutic patents* **2014**, *24* (6), 609-32.

21. Suzuki, T.; Yamamoto, N.; Nonaka, M.; Hashimoto, Y.; Matsuda, G.; Takeshima, S. N.; Matsuyama, M.; Igarashi, T.; Miura, T.; Tanaka, R.; Kato, S.; Aida, Y., Inhibition of human immunodeficiency virus type 1 (HIV-1) nuclear

import via Vpr-Importin alpha interactions as a novel HIV-1 therapy. *Biochemical and biophysical research communications* **2009**, *380* (4), 838-43.

22. Para, M. F.; Schouten, J.; Rosenkranz, S. L.; Yu, S.; Weiner, D.; Tebas, P.; White, C. J.; Reeds, D.; Lertora, J.; Patterson, K. B.; Daar, E. S.; Cavert, W.; Brizz, B., Phase I/II trial of the anti-HIV activity of mifepristone in HIV-infected subjects ACTG 5200. *J Acquir Immune Defic Syndr* **2010**, *53* (4), 491-5.

23. Schafer, E. A.; Venkatachari, N. J.; Ayyavoo, V., Antiviral effects of mifepristone on human immunodeficiency virus type-1 (HIV-1): targeting Vpr and its cellular partner, the glucocorticoid receptor (GR). *Antiviral research* **2006**, *72* (3), 224-32.

24. Refaeli, Y.; Levy, D. N.; Weiner, D. B., The glucocorticoid receptor type II complex is a target of the HIV-1 vpr gene product. *Proceedings of the National Academy of Sciences of the United States of America* **1995**, *92* (8), 3621-5.

25. Chao, S. H.; Fujinaga, K.; Marion, J. E.; Taube, R.; Sausville, E. A.; Senderowicz, A. M.; Peterlin, B. M.; Price, D. H., Flavopiridol inhibits P-TEFb and blocks HIV-1 replication. *The Journal of biological chemistry* **2000**, *275* (37), 28345-8.

26. Wang, D.; de la Fuente, C.; Deng, L.; Wang, L.; Zilberman, I.; Eadie, C.; Healey, M.; Stein, D.; Denny, T.; Harrison, L. E.; Meijer, L.; Kashanchi, F., Inhibition of human immunodeficiency virus type 1 transcription by chemical cyclin-dependent kinase inhibitors. *Journal of virology* **2001**, *75* (16), 7266-79.

27. (a) Heredia, A.; Davis, C.; Bamba, D.; Le, N.; Gwarzo, M. Y.; Sadowska, M.; Gallo, R. C.; Redfield, R. R., Indirubin-3'-monoxime, a derivative of a Chinese antileukemia medicine, inhibits P-TEFb function and HIV-1 replication. *AIDS* **2005**, *19* (18), 2087-95; (b) Heredia, A.; Natesan, S.; Le, N. M.; Medina-Moreno, S.; Zapata, J. C.; Reitz, M.; Bryant, J.; Redfield, R. R., Indirubin 3'-monoxime, from a Chinese traditional herbal formula, suppresses viremia in humanized mice infected with multidrug-resistant HIV. *AIDS research and human retroviruses* **2014**, *30* (5), 403-6.

28. Sancineto, L.; Iraci, N.; Massari, S.; Attanasio, V.; Corazza, G.; Barreca, M. L.; Sabatini, S.; Manfroni, G.; Avanzi, N. R.; Cecchetti, V.; Pannecouque, C.; Marcello, A.; Tabarrini, O., Computer-aided design, synthesis and validation of 2-phenylquinazolinone fragments as CDK9 inhibitors with anti-HIV-1 Tat-mediated transcription activity. *ChemMedChem* **2013**, *8* (12), 1941-53.

29. Van Duyne, R.; Guendel, I.; Jaworski, E.; Sampey, G.; Klase, Z.; Chen, H.; Zeng, C.; Kovalskyy, D.; El Kouni, M. H.; Lepene, B.; Patanarut, A.; Nekhai, S.; Price, D. H.; Kashanchi, F., Effect of mimetic CDK9 inhibitors on HIV-1-

activated transcription. *Journal of molecular biology* **2013**, *425* (4), 812-29.

30. Hamasaki, T.; Okamoto, M.; Baba, M., Identification of novel inhibitors of human immunodeficiency virus type 1 replication by in silico screening targeting cyclin T1/Tat interaction. *Antimicrobial agents and chemotherapy* **2013**, *57* (3), 1323-31.

31. Schafer, B.; Hauber, I.; Bunk, A.; Heukeshoven, J.; Dusedau, A.; Bevec, D.; Hauber, J., Inhibition of multidrug-resistant HIV-1 by interference with cellular S-adenosylmethionine decarboxylase activity. *The Journal of infectious diseases* **2006**, *194* (6), 740-50.

32. Hauber, I.; Bevec, D.; Heukeshoven, J.; Kratzer, F.; Horn, F.; Choidas, A.; Harrer, T.; Hauber, J., Identification of cellular deoxyhypusine synthase as a novel target for antiretroviral therapy. *The Journal of clinical investigation* **2005**, *115* (1), 76-85.

33. Daelemans, D.; Afonina, E.; Nilsson, J.; Werner, G.; Kjems, J.; De Clercq, E.; Pavlakis, G. N.; Vandamme, A. M., A synthetic HIV-1 Rev inhibitor interfering with the CRM1-mediated nuclear export. *Proceedings of the National Academy of Sciences of the United States of America* **2002**, *99* (22), 14440-5.

34. Fleta-Soriano, E.; Martinez, J. P.; Hinkelmann, B.; Gerth, K.; Washausen, P.; Diez, J.; Frank, R.; Sasse, F.; Meyerhans, A., The myxobacterial metabolite ratjadone A inhibits HIV infection by blocking the Rev/CRM1-mediated nuclear export pathway. *Microbial cell factories* **2014**, *13*, 17.

35. Murakami, N.; Ye, Y.; Kawanishi, M.; Aoki, S.; Kudo, N.; Yoshida, M.; Nakayama, E. E.; Shioda, T.; Kobayashi, M., New Rev-transport inhibitor with anti-HIV activity from *Valeriana Radix*. *Bioorganic & medicinal chemistry letters* **2002**, *12* (20), 2807-10.

36. Yedavalli, V. S.; Zhang, N.; Cai, H.; Zhang, P.; Starost, M. F.; Hosmane, R. S.; Jeang, K. T., Ring expanded nucleoside analogues inhibit RNA helicase and intracellular human immunodeficiency virus type 1 replication. *Journal of medicinal chemistry* **2008**, *51* (16), 5043-51.

37. Maga, G.; Falchi, F.; Garbelli, A.; Belfiore, A.; Witvrouw, M.; Manetti, F.; Botta, M., Pharmacophore modeling and molecular docking led to the discovery of inhibitors of human immunodeficiency virus-1 replication targeting the human cellular aspartic acid-glutamic acid-alanine-aspartic acid box polypeptide 3. *Journal of medicinal chemistry* **2008**, *51* (21), 6635-8.

38. Radi, M.; Falchi, F.; Garbelli, A.; Samuele, A.; Bernardo, V.; Paolucci, S.; Baldanti, F.; Schenone, S.; Manetti, F.; Maga, G.; Botta, M., Discovery of the first small molecule inhibitor of human DDX3 specifically designed to target the RNA binding site: towards the next generation HIV-1 inhibitors. *Bioorganic & medicinal chemistry letters* **2012**, *22* (5), 2094-8.

39. Betzi, S.; Restouin, A.; Opi, S.; Arold, S. T.; Parrot, I.; Guerlesquin, F.; Morelli, X.; Collette, Y., Protein protein interaction inhibition (2P2I) combining high throughput and virtual screening: Application to the HIV-1 Nef protein. *Proceedings of the National Academy of Sciences of the United States of America* **2007**, *104* (49), 19256-61.
40. Tribble, R. P.; Narute, P.; Emert-Sedlak, L. A.; Alvarado, J. J.; Atkins, K.; Thomas, L.; Kodama, T.; Yanamala, N.; Korotchenko, V.; Day, B. W.; Thomas, G.; Smithgall, T. E., Discovery of a diaminoquinoxaline benzenesulfonamide antagonist of HIV-1 Nef function using a yeast-based phenotypic screen. *Retrovirology* **2013**, *10*, 135.
41. Smithgall, T. E.; Thomas, G., Small molecule inhibitors of the HIV-1 virulence factor, Nef. *Drug discovery today. Technologies* **2013**, *10* (4), e523-9.
42. Dikeakos, J. D.; Atkins, K. M.; Thomas, L.; Emert-Sedlak, L.; Byeon, I. J.; Jung, J.; Ahn, J.; Wortman, M. D.; Kukull, B.; Saito, M.; Koizumi, H.; Williamson, D. M.; Hiyoshi, M.; Barklis, E.; Takiguchi, M.; Suzu, S.; Gronenborn, A. M.; Smithgall, T. E.; Thomas, G., Small molecule inhibition of HIV-1-induced MHC-I down-regulation identifies a temporally regulated switch in Nef action. *Molecular biology of the cell* **2010**, *21* (19), 3279-92.
43. Emert-Sedlak, L. A.; Narute, P.; Shu, S. T.; Poe, J. A.; Shi, H.; Yanamala, N.; Alvarado, J. J.; Lazo, J. S.; Yeh, J. I.; Johnston, P. A.; Smithgall, T. E., Effector kinase coupling enables high-throughput screens for direct HIV-1 Nef antagonists with antiretroviral activity. *Chemistry & biology* **2013**, *20* (1), 82-91.
44. Emert-Sedlak, L.; Kodama, T.; Lerner, E. C.; Dai, W.; Foster, C.; Day, B. W.; Lazo, J. S.; Smithgall, T. E., Chemical library screens targeting an HIV-1 accessory factor/host cell kinase complex identify novel antiretroviral compounds. *ACS chemical biology* **2009**, *4* (11), 939-47.
45. Olszewski, A.; Sato, K.; Aron, Z. D.; Cohen, F.; Harris, A.; McDougall, B. R.; Robinson, W. E., Jr.; Overman, L. E.; Weiss, G. A., Guanidine alkaloid analogs as inhibitors of HIV-1 Nef interactions with p53, actin, and p56lck. *Proceedings of the National Academy of Sciences of the United States of America* **2004**, *101* (39), 14079-84.
46. Arkin, M. R.; Wells, J. A., Small-molecule inhibitors of protein-protein interactions: progressing towards the dream. *Nature reviews. Drug discovery* **2004**, *3* (4), 301-17.
47. Marx, A.; Alian, A., The Road Less Traveled: HIV's Use of Alternative Routes through Cellular Pathways. *Journal of virology* **2015**, *89* (10), 5204-5212.
48. Nguyen, G. T.; Carrington, M.; Beeler, J. A.; Dean, M.; Aledort, L. M.; Blatt, P. M.; Cohen, A. R.; DiMichele, D.; Eyster, M. E.; Kessler, C. M.; Konkle, B.; Leissinger, C.; Luban, N.; O'Brien, S. J.; Goedert, J. J.; O'Brien, T. R., Phenotypic expressions of CCR5-delta32/delta32 homozygosity. *J Acquir Immune Defic Syndr* **1999**, *22* (1), 75-82.
49. (a) Brass, A. L.; Dykxhoorn, D. M.; Benita, Y.; Yan, N.; Engelman, A.; Xavier, R. J.; Lieberman, J.; Elledge, S. J., Identification of host proteins required for HIV infection through a functional genomic screen. *Science* **2008**, *319* (5865), 921-6; (b) Konig, R.; Zhou, Y.; Elleder, D.; Diamond, T. L.; Bonamy, G. M.; Irelan, J. T.; Chiang, C. Y.; Tu, B. P.; De Jesus, P. D.; Lilley, C. E.; Seidel, S.; Opaluch, A. M.; Caldwell, J. S.; Weitzman, M. D.; Kuhlen, K. L.; Bandyopadhyay, S.; Ideker, T.; Orth, A. P.; Miraglia, L. J.; Bushman, F. D.; Young, J. A.; Chanda, S. K., Global analysis of host-pathogen interactions that regulate early-stage HIV-1 replication. *Cell* **2008**, *135* (1), 49-60; (c) Zhou, H.; Xu, M.; Huang, Q.; Gates, A. T.; Zhang, X. D.; Castle, J. C.; Stec, E.; Ferrer, M.; Strulovici, B.; Hazuda, D. J.; Espeseth, A. S., Genome-scale RNAi screen for host factors required for HIV replication. *Cell host & microbe* **2008**, *4* (5), 495-504; (d) Yeung, M. L.; Houzet, L.; Yedavalli, V. S.; Jeang, K. T., A genome-wide short hairpin RNA screening of jurkat T-cells for human proteins contributing to productive HIV-1 replication. *The Journal of biological chemistry* **2009**, *284* (29), 19463-73.
50. Rain, J. C.; Cribier, A.; Gerard, A.; Emiliani, S.; Benarous, R., Yeast two-hybrid detection of integrase-host factor interactions. *Methods* **2009**, *47* (4), 291-7.
51. Jager, S.; Cimermancic, P.; Gulbahce, N.; Johnson, J. R.; McGovern, K. E.; Clarke, S. C.; Shales, M.; Mercenne, G.; Pache, L.; Li, K.; Hernandez, H.; Jang, G. M.; Roth, S. L.; Akiva, E.; Marlett, J.; Stephens, M.; D'Orso, I.; Fernandes, J.; Fahey, M.; Mahon, C.; O'Donoghue, A. J.; Todorovic, A.; Morris, J. H.; Maltby, D. A.; Alber, T.; Cagney, G.; Bushman, F. D.; Young, J. A.; Chanda, S. K.; Sundquist, W. I.; Kortemme, T.; Hernandez, R. D.; Craik, C. S.; Burlingame, A.; Sali, A.; Frankel, A. D.; Krogan, N. J., Global landscape of HIV-human protein complexes. *Nature* **2012**, *481* (7381), 365-70.
52. Micewicz, E. D.; Ruchala, P., Inhibitors of HIV-1 entry. *Current pharmaceutical design* **2013**, *19* (10), 1784-99.
53. Leng, J.; Ho, H. P.; Buzon, M. J.; Pereyra, F.; Walker, B. D.; Yu, X. G.; Chang, E. J.; Lichtenfeld, M., A cell-intrinsic inhibitor of HIV-1 reverse transcription in CD4(+) T cells from elite controllers. *Cell host & microbe* **2014**, *15* (6), 717-28.
54. Sokolskaja, E.; Sayah, D. M.; Luban, J., Target cell cyclophilin A modulates human immunodeficiency virus type 1 infectivity. *Journal of virology* **2004**, *78* (23), 12800-8.
55. Price, A. J.; Fletcher, A. J.; Schaller, T.; Elliott, T.; Lee, K.; KewalRamani, V. N.; Chin, J. W.; Towers, G. J.; James, L. C., CPSF6 defines a conserved capsid interface that modulates HIV-1 replication. *PLoS pathogens* **2012**, *8* (8), e1002896.
56. (a) Zhang, R.; Mehla, R.; Chauhan, A., Perturbation of host nuclear membrane component RanBP2 impairs the

nuclear import of human immunodeficiency virus -1 preintegration complex (DNA). *PloS one* **2010**, *5* (12), e15620; (b) Christ, F.; Thys, W.; De Rijck, J.; Gijssbers, R.; Albanese, A.; Arosio, D.; Emiliani, S.; Rain, J. C.; Benarous, R.; Cereseto, A.; Debyser, Z., Transportin-SR2 imports HIV into the nucleus. *Current biology : CB* **2008**, *18* (16), 1192-202.

57. (a) Yedavalli, V. S.; Neuveut, C.; Chi, Y. H.; Kleiman, L.; Jeang, K. T., Requirement of DDX3 DEAD box RNA helicase for HIV-1 Rev-RRE export function. *Cell* **2004**, *119* (3), 381-92; (b) Neville, M.; Stutz, F.; Lee, L.; Davis, L. I.; Rosbash, M., The importin-beta family member Crm1p bridges the interaction between Rev and the nuclear pore complex during nuclear export. *Current biology : CB* **1997**, *7* (10), 767-75.

58. Garrus, J. E.; von Schwedler, U. K.; Pornillos, O. W.; Morham, S. G.; Zavitz, K. H.; Wang, H. E.; Wettstein, D. A.; Stray, K. M.; Cote, M.; Rich, R. L.; Myszka, D. G.; Sundquist, W. I., Tsg101 and the vacuolar protein sorting pathway are essential for HIV-1 budding. *Cell* **2001**, *107* (1), 55-65.

59. Strack, B.; Calistri, A.; Craig, S.; Popova, E.; Gottlinger, H. G., AIP1/ALIX is a binding partner for HIV-1 p6 and EIAV p9 functioning in virus budding. *Cell* **2003**, *114* (6), 689-99.

60. Sheehy, A. M.; Gaddis, N. C.; Choi, J. D.; Malim, M. H., Isolation of a human gene that inhibits HIV-1 infection and is suppressed by the viral Vif protein. *Nature* **2002**, *418* (6898), 646-50.

61. (a) Vandekerckhove, L.; Christ, F.; Van Maele, B.; De Rijck, J.; Gijssbers, R.; Van den Haute, C.; Witvrouw, M.; Debyser, Z., Transient and stable knockdown of the integrase cofactor LEDGF/p75 reveals its role in the replication cycle of human immunodeficiency virus. *Journal of virology* **2006**, *80* (4), 1886-96; (b) Llano, M.; Saenz, D. T.; Meehan, A.; Wongthida, P.; Peretz, M.; Walker, W. H.; Teo, W.; Poeschla, E. M., An essential role for LEDGF/p75 in HIV integration. *Science* **2006**, *314* (5798), 461-4; (c) Schrijvers, R.; De Rijck, J.; Demeulemeester, J.; Adachi, N.; Vets, S.; Ronen, K.; Christ, F.; Bushman, F. D.; Debyser, Z.; Gijssbers, R., LEDGF/p75-independent HIV-1 replication demonstrates a role for HRP-2 and remains sensitive to inhibition by LEDGInS. *PLoS pathogens* **2012**, *8* (3), e1002558; (d) Wang, H.; Jurado, K. A.; Wu, X.; Shun, M. C.; Li, X.; Ferris, A. L.; Smith, S. J.; Patel, P. A.; Fuchs, J. R.; Cherepanov, P.; Kvaratskhelia, M.; Hughes, S. H.; Engelman, A., HRP2 determines the efficiency and specificity of HIV-1 integration in LEDGF/p75 knockout cells but does not contribute to the antiviral activity of a potent LEDGF/p75-binding site integrase inhibitor. *Nucleic acids research* **2012**, *40* (22), 11518-30.

62. Engelman, A.; Cherepanov, P., Retroviral Integrase Structure and DNA Recombination Mechanism. *Microbiology spectrum* **2014**, *2* (6), 1-22.

63. Cherepanov, P.; Maertens, G.; Proost, P.; Devreese, B.; Van Beeumen, J.; Engelborghs, Y.; De Clercq, E.; Debyser, Z., HIV-1 integrase forms stable tetramers and associates with LEDGF/p75 protein in human cells. *The Journal of biological chemistry* **2003**, *278* (1), 372-81.

64. Ge, H.; Si, Y.; Roeder, R. G., Isolation of cDNAs encoding novel transcription coactivators p52 and p75 reveals an alternate regulatory mechanism of transcriptional activation. *The EMBO journal* **1998**, *17* (22), 6723-9.

65. Pradeepa, M. M.; Sutherland, H. G.; Ule, J.; Grimes, G. R.; Bickmore, W. A., Psp1/Ledgf p52 binds methylated histone H3K36 and splicing factors and contributes to the regulation of alternative splicing. *PLoS genetics* **2012**, *8* (5), e1002717.

66. (a) Llano, M.; Vanegas, M.; Hutchins, N.; Thompson, D.; Delgado, S.; Poeschla, E. M., Identification and characterization of the chromatin-binding domains of the HIV-1 integrase interactor LEDGF/p75. *Journal of molecular biology* **2006**, *360* (4), 760-73; (b) Tsutsui, K. M.; Sano, K.; Hosoya, O.; Miyamoto, T.; Tsutsui, K., Nuclear protein LEDGF/p75 recognizes supercoiled DNA by a novel DNA-binding domain. *Nucleic acids research* **2011**, *39* (12), 5067-81; (c) Maertens, G.; Cherepanov, P.; Debyser, Z.; Engelborghs, Y.; Engelman, A., Identification and characterization of a functional nuclear localization signal in the HIV-1 integrase interactor LEDGF/p75. *The Journal of biological chemistry* **2004**, *279* (32), 33421-9.

67. (a) Cherepanov, P.; Devroe, E.; Silver, P. A.; Engelman, A., Identification of an evolutionarily conserved domain in human lens epithelium-derived growth factor/transcriptional co-activator p75 (LEDGF/p75) that binds HIV-1 integrase. *The Journal of biological chemistry* **2004**, *279* (47), 48883-92; (b) Turlure, F.; Maertens, G.; Rahman, S.; Cherepanov, P.; Engelman, A., A tripartite DNA-binding element, comprised of the nuclear localization signal and two AT-hook motifs, mediates the association of LEDGF/p75 with chromatin in vivo. *Nucleic acids research* **2006**, *34* (5), 1653-65.

68. (a) Maertens, G. N.; Cherepanov, P.; Engelman, A., Transcriptional co-activator p75 binds and tethers the Myc-interacting protein JPO2 to chromatin. *Journal of cell science* **2006**, *119* (Pt 12), 2563-71; (b) Bartholomeeusen, K.; Christ, F.; Hendrix, J.; Rain, J. C.; Emiliani, S.; Benarous, R.; Debyser, Z.; Gijssbers, R.; De Rijck, J., Lens epithelium-derived growth factor/p75 interacts with the transposase-derived DDE domain of PogZ. *The Journal of biological chemistry* **2009**, *284* (17), 11467-77; (c) Yokoyama, A.; Cleary, M. L., Menin critically links MLL proteins with LEDGF on cancer-associated target genes. *Cancer cell* **2008**, *14* (1), 36-46.

69. (a) Shun, M. C.; Raghavendra, N. K.; Vandegraaff, N.; Daigle, J. E.; Hughes, S.; Kellam, P.; Cherepanov, P.; Engelman, A., LEDGF/p75 functions downstream from preintegration complex formation to effect gene-specific HIV-1 integration. *Genes & development* **2007**, *21* (14), 1767-78; (b) Ciuffi, A.; Bushman, F. D., Retroviral DNA integration: HIV and the role of LEDGF/p75. *Trends Genet* **2006**, *22* (7), 388-95.
70. (a) Llano, M.; Delgado, S.; Vanegas, M.; Poeschla, E. M., Lens epithelium-derived growth factor/p75 prevents proteasomal degradation of HIV-1 integrase. *The Journal of biological chemistry* **2004**, *279* (53), 55570-7; (b) Marshall, H. M.; Ronen, K.; Berry, C.; Llano, M.; Sutherland, H.; Saenz, D.; Bickmore, W.; Poeschla, E.; Bushman, F. D., Role of PSIP1/LEDGF/p75 in lentiviral infectivity and integration targeting. *PloS one* **2007**, *2* (12), e1340; (c) Botbol, Y.; Raghavendra, N. K.; Rahman, S.; Engelman, A.; Lavigne, M., Chromatinized templates reveal the requirement for the LEDGF/p75 PWWP domain during HIV-1 integration in vitro. *Nucleic acids research* **2008**, *36* (4), 1237-46; (d) Kessl, J. J.; Li, M.; Ignatov, M.; Shkriabai, N.; Eidahl, J. O.; Feng, L.; Musier-Forsyth, K.; Craigie, R.; Kvaratskhelia, M., FRET analysis reveals distinct conformations of IN tetramers in the presence of viral DNA or LEDGF/p75. *Nucleic acids research* **2011**, *39* (20), 9009-22.
71. Cherepanov, P.; Ambrosio, A. L.; Rahman, S.; Ellenberger, T.; Engelman, A., Structural basis for the recognition between HIV-1 integrase and transcriptional coactivator p75. *Proceedings of the National Academy of Sciences of the United States of America* **2005**, *102* (48), 17308-13.
72. (a) Hombrouck, A.; De Rijck, J.; Hendrix, J.; Vandekerckhove, L.; Voet, A.; De Maeyer, M.; Witvrouw, M.; Engelborghs, Y.; Christ, F.; Gijsbers, R.; Debyser, Z., Virus evolution reveals an exclusive role for LEDGF/p75 in chromosomal tethering of HIV. *PLoS pathogens* **2007**, *3* (3), e47; (b) Emiliani, S.; Mousnier, A.; Busschots, K.; Maroun, M.; Van Maele, B.; Tempe, D.; Vandekerckhove, L.; Moisant, F.; Ben-Slama, L.; Witvrouw, M.; Christ, F.; Rain, J. C.; Dargemont, C.; Debyser, Z.; Benarous, R., Integrase mutants defective for interaction with LEDGF/p75 are impaired in chromosome tethering and HIV-1 replication. *J Biol Chem* **2005**, *280* (27), 25517-23; (c) Busschots, K.; Voet, A.; De Maeyer, M.; Rain, J. C.; Emiliani, S.; Benarous, R.; Desender, L.; Debyser, Z.; Christ, F., Identification of the LEDGF/p75 binding site in HIV-1 integrase. *Journal of molecular biology* **2007**, *365* (5), 1480-92.
73. (a) De Rijck, J.; Vandekerckhove, L.; Gijsbers, R.; Hombrouck, A.; Hendrix, J.; Vercammen, J.; Engelborghs, Y.; Christ, F.; Debyser, Z., Overexpression of the lens epithelium-derived growth factor/p75 integrase binding domain inhibits human immunodeficiency virus replication. *Journal of virology* **2006**, *80* (23), 11498-509; (b) Hayouka, Z.; Rosenbluh, J.; Levin, A.; Loya, S.; Lebendiker, M.; Veprintsev, D.; Kotler, M.; Hizi, A.; Loyter, A.; Friedler, A., Inhibiting HIV-1 integrase by shifting its oligomerization equilibrium. *Proceedings of the National Academy of Sciences of the United States of America* **2007**, *104* (20), 8316-21; (c) Al-Mawsawi, L. Q.; Christ, F.; Dayam, R.; Debyser, Z.; Neamati, N., Inhibitory profile of a LEDGF/p75 peptide against HIV-1 integrase: insight into integrase-DNA complex formation and catalysis. *FEBS letters* **2008**, *582* (10), 1425-30.
74. Christ, F.; Voet, A.; Marchand, A.; Nicolet, S.; Desimmie, B. A.; Marchand, D.; Bardiot, D.; Van der Veken, N. J.; Van Remoortel, B.; Strelkov, S. V.; De Maeyer, M.; Chaltin, P.; Debyser, Z., Rational design of small-molecule inhibitors of the LEDGF/p75-integrase interaction and HIV replication. *Nature chemical biology* **2010**, *6* (6), 442-8.
75. Schrodinger, LLC *The PyMOL Molecular Graphics System, Version 1.3r1*, 2010.
76. Desimmie, B. A.; Humbert, M.; Lescrier, E.; Hendrix, J.; Vets, S.; Gijsbers, R.; Ruprecht, R. M.; Dietrich, U.; Debyser, Z.; Christ, F., Phage display-directed discovery of LEDGF/p75 binding cyclic peptide inhibitors of HIV replication. *Molecular therapy : the journal of the American Society of Gene Therapy* **2012**, *20* (11), 2064-75.
77. Molteni, V.; Greenwald, J.; Rhodes, D.; Hwang, Y.; Kwiatkowski, W.; Bushman, F. D.; Siegel, J. S.; Choe, S., Identification of a small-molecule binding site at the dimer interface of the HIV integrase catalytic domain. *Acta crystallographica. Section D, Biological crystallography* **2001**, *57* (Pt 4), 536-44.
78. Christ, F.; Shaw, S.; Demeulemeester, J.; Desimmie, B. A.; Marchand, A.; Butler, S.; Smets, W.; Chaltin, P.; Westby, M.; Debyser, Z.; Pickford, C., Small-molecule inhibitors of the LEDGF/p75 binding site of integrase block HIV replication and modulate integrase multimerization. *Antimicrobial agents and chemotherapy* **2012**, *56* (8), 4365-74.
79. De Luca, L.; Barreca, M. L.; Ferro, S.; Christ, F.; Iraci, N.; Gitto, R.; Monforte, A. M.; Debyser, Z.; Chimirri, A., Pharmacophore-based discovery of small-molecule inhibitors of protein-protein interactions between HIV-1 integrase and cellular cofactor LEDGF/p75. *ChemMedChem* **2009**, *4* (8), 1311-6.
80. (a) Fader, L. D.; Malenfant, E.; Parisien, M.; Carson, R.; Bilodeau, F.; Landry, S.; Pesant, M.; Brochu, C.; Morin, S.; Chabot, C.; Halmos, T.; Bousquet, Y.; Bailey, M. D.; Kawai, S. H.; Coulombe, R.; LaPlante, S.; Jakalian, A.; Bhardwaj, P. K.; Wernic, D.; Schroeder, P.; Amad, M.; Edwards, P.; Garneau, M.; Duan, J.; Cordingley, M.; Bethell, R.; Mason, S. W.; Bos, M.; Bonneau, P.; Poupart, M. A.; Faucher, A.

- M.; Simoneau, B.; Fenwick, C.; Yoakim, C.; Tsantrizos, Y., Discovery of BI 224436, a Noncatalytic Site Integrase Inhibitor (NCINI) of HIV-1. *ACS medicinal chemistry letters* **2014**, *5* (4), 422-7; (b) Fenwick, C.; Amad, M.; Bailey, M. D.; Bethell, R.; Bos, M.; Bonneau, P.; Cordingley, M.; Coulombe, R.; Duan, J.; Edwards, P.; Fader, L. D.; Faucher, A. M.; Garneau, M.; Jakalian, A.; Kawai, S.; Lamorte, L.; LaPlante, S.; Luo, L.; Mason, S.; Poupart, M. A.; Rioux, N.; Schroeder, P.; Simoneau, B.; Tremblay, S.; Tsantrizos, Y.; Witvrouw, M.; Yoakim, C., Preclinical profile of BI 224436, a novel HIV-1 non-catalytic-site integrase inhibitor. *Antimicrobial agents and chemotherapy* **2014**, *58* (6), 3233-44.
81. Fader, L. D.; Carson, R.; Morin, S.; Bilodeau, F.; Chabot, C.; Halmos, T.; Bailey, M. D.; Kawai, S. H.; Coulombe, R.; Laplante, S.; Mekhssian, K.; Jakalian, A.; Garneau, M.; Duan, J.; Mason, S. W.; Simoneau, B.; Fenwick, C.; Tsantrizos, Y.; Yoakim, C., Minimizing the Contribution of Enterohepatic Recirculation to Clearance in Rat for the NCINI Class of Inhibitors of HIV. *ACS medicinal chemistry letters* **2014**, *5* (6), 711-6.
82. Sharma, A.; Slaughter, A.; Jena, N.; Feng, L.; Kessler, J. J.; Fadel, H. J.; Malani, N.; Male, F.; Wu, L.; Poeschla, E.; Bushman, F. D.; Fuchs, J. R.; Kvaratskhelia, M., A new class of multimerization selective inhibitors of HIV-1 integrase. *PLoS pathogens* **2014**, *10* (5), e1004171.
83. (a) Le Rouzic, E.; Bonnard, D.; Chasset, S.; Bruneau, J. M.; Chevreuril, F.; Le Strat, F.; Nguyen, J.; Beauvoir, R.; Amadori, C.; Brias, J.; Vomscheid, S.; Eiler, S.; Levy, N.; Delelis, O.; Deprez, E.; Saib, A.; Zamborlini, A.; Emiliani, S.; Ruff, M.; Ledoussal, B.; Moreau, F.; Benarous, R., Dual inhibition of HIV-1 replication by integrase-LEDGF allosteric inhibitors is predominant at the post-integration stage. *Retrovirology* **2013**, *10*, 144; (b) Balakrishnan, M.; Yant, S. R.; Tsai, L.; O'Sullivan, C.; Bam, R. A.; Tsai, A.; Niedziela-Majka, A.; Stray, K. M.; Sakowicz, R.; Cihlar, T., Non-catalytic site HIV-1 integrase inhibitors disrupt core maturation and induce a reverse transcription block in target cells. *PLoS one* **2013**, *8* (9), e74163; (c) Gupta, K.; Brady, T.; Dyer, B. M.; Malani, N.; Hwang, Y.; Male, F.; Nolte, R. T.; Wang, L.; Velthuisen, E.; Jeffrey, J.; Van Duyne, G. D.; Bushman, F. D., Allosteric inhibition of human immunodeficiency virus integrase: late block during viral replication and abnormal multimerization involving specific protein domains. *The Journal of biological chemistry* **2014**, *289* (30), 20477-88.
84. (a) Hu, G.; Li, X.; Sun, X.; Lu, W.; Liu, G.; Huang, J.; Shen, X.; Tang, Y., Identification of old drugs as potential inhibitors of HIV-1 integrase - human LEDGF/p75 interaction via molecular docking. *Journal of molecular modeling* **2012**, *18* (12), 4995-5003; (b) Sanchez, T. W.; Debnath, B.; Christ, F.; Otake, H.; Debyser, Z.; Neamati, N., Discovery of novel inhibitors of LEDGF/p75-IN protein-protein interactions. *Bioorganic & medicinal chemistry* **2013**, *21* (4), 957-63; (c) De Luca, L.; Morreale, F.; Christ, F.; Debyser, Z.; Ferro, S.; Gitto, R., New scaffolds of natural origin as Integrase-LEDGF/p75 interaction inhibitors: virtual screening and activity assays. *European journal of medicinal chemistry* **2013**, *68*, 405-11; (d) Rogolino, D.; Carcelli, M.; Compari, C.; De Luca, L.; Ferro, S.; Fiscaro, E.; Rispoli, G.; Neamati, N.; Debyser, Z.; Christ, F.; Chimirri, A., Diketoacid chelating ligands as dual inhibitors of HIV-1 integration process. *European journal of medicinal chemistry* **2014**, *78*, 425-30.
85. (a) Demeulemeester, J.; Tintori, C.; Botta, M.; Debyser, Z.; Christ, F., Development of an AlphaScreen-based HIV-1 integrase dimerization assay for discovery of novel allosteric inhibitors. *Journal of biomolecular screening* **2012**, *17* (5), 618-28; (b) Desimmie, B. A.; Schrijvers, R.; Demeulemeester, J.; Borrenberghs, D.; Weydert, C.; Thys, W.; Vets, S.; Van Remoortel, B.; Hofkens, J.; De Rijck, J.; Hendrix, J.; Bannert, N.; Gijssbers, R.; Christ, F.; Debyser, Z., LEDGINS inhibit late stage HIV-1 replication by modulating integrase multimerization in the virions. *Retrovirology* **2013**, *10*, 57; (c) Kessler, J. J.; Jena, N.; Koh, Y.; Taskent-Sezgin, H.; Slaughter, A.; Feng, L.; de Silva, S.; Wu, L.; Le Grice, S. F.; Engelman, A.; Fuchs, J. R.; Kvaratskhelia, M., Multimode, cooperative mechanism of action of allosteric HIV-1 integrase inhibitors. *The Journal of biological chemistry* **2012**, *287* (20), 16801-11.
86. Slaughter, A.; Jurado, K. A.; Deng, N.; Feng, L.; Kessler, J. J.; Shkriabai, N.; Larue, R. C.; Fadel, H. J.; Patel, P. A.; Jena, N.; Fuchs, J. R.; Poeschla, E.; Levy, R. M.; Engelman, A.; Kvaratskhelia, M., The mechanism of H171T resistance reveals the importance of N-protonated His171 for the binding of allosteric inhibitor BI-D to HIV-1 integrase. *Retrovirology* **2014**, *11* (1), 100.
87. (a) Agbottah, E.; de La Fuente, C.; Nekhai, S.; Barnett, A.; Gianella-Borradori, A.; Pumfery, A.; Kashanchi, F., Antiviral activity of CYC202 in HIV-1-infected cells. *The Journal of biological chemistry* **2005**, *280* (4), 3029-42; (b) Narayanan, A.; Sampey, G.; Van Duyne, R.; Guendel, I.; Kehn-Hall, K.; Roman, J.; Curren, R.; Galons, H.; Oumata, N.; Joseph, B.; Meijer, L.; Caputi, M.; Nekhai, S.; Kashanchi, F., Use of ATP analogs to inhibit HIV-1 transcription. *Virology* **2012**, *432* (1), 219-31.
88. Nemeth, G.; Greff, Z.; Sipos, A.; Varga, Z.; Szekely, R.; Sebestyen, M.; Jaszay, Z.; Beni, S.; Nemes, Z.; Pirat, J. L.; Volle, J. N.; Virieux, D.; Gyuris, A.; Kelemenics, K.; Ay, E.; Minarovits, J.; Szathmary, S.; Keri, G.; Orfi, L., Synthesis and evaluation of phosphorus containing, specific CDK9/CycT1 inhibitors. *Journal of medicinal chemistry* **2014**, *57* (10), 3939-65.
89. Zuo, T.; Liu, D.; Lv, W.; Wang, X.; Wang, J.; Lv, M.; Huang, W.; Wu, J.; Zhang, H.; Jin, H.; Zhang, L.; Kong, W.; Yu, X., Small-molecule inhibition of human

- immunodeficiency virus type 1 replication by targeting the interaction between Vif and ElonginC. *Journal of virology* **2012**, *86* (10), 5497-507.
90. Jurado, K. A.; Wang, H.; Slaughter, A.; Feng, L.; Kessler, J. J.; Koh, Y.; Wang, W.; Ballandras-Colas, A.; Patel, P. A.; Fuchs, J. R.; Kvaratskhelia, M.; Engelman, A., Allosteric integrase inhibitor potency is determined through the inhibition of HIV-1 particle maturation. *Proceedings of the National Academy of Sciences of the United States of America* **2013**, *110* (21), 8690-5.
91. Desimmie, B. A.; Weydert, C.; Schrijvers, R.; Vets, S.; Demeulemeester, J.; Proost, P.; Paron, I.; De Rijck, J.; Mast, J.; Bannert, N.; Gijssbers, R.; Christ, F.; Debysier, Z., HIV-1 IN/Pol recruits LEDGF/p75 into viral particles. *Retrovirology* **2015**, *12* (1), 16.
92. Fadel, H. J.; Morrison, J. H.; Saenz, D. T.; Fuchs, J. R.; Kvaratskhelia, M.; Ekker, S. C.; Poeschla, E. M., TALEN knockout of the PSIP1 gene in human cells: analyses of HIV-1 replication and allosteric integrase inhibitor mechanism. *Journal of virology* **2014**, *88* (17), 9704-17.
93. Campbell, G. R.; Loret, E. P., What does the structure-function relationship of the HIV-1 Tat protein teach us about developing an AIDS vaccine? *Retrovirology* **2009**, *6*, 50.
94. (a) Wei, P.; Garber, M. E.; Fang, S. M.; Fischer, W. H.; Jones, K. A., A novel CDK9-associated C-type cyclin interacts directly with HIV-1 Tat and mediates its high-affinity, loop-specific binding to TAR RNA. *Cell* **1998**, *92* (4), 451-62; (b) Mancebo, H. S.; Lee, G.; Flygare, J.; Tomassini, J.; Luu, P.; Zhu, Y.; Peng, J.; Blau, C.; Hazuda, D.; Price, D.; Flores, O., P-TEFb kinase is required for HIV Tat transcriptional activation in vivo and in vitro. *Genes & development* **1997**, *11* (20), 2633-44.
95. Zhu, Y.; Pe'ery, T.; Peng, J.; Ramanathan, Y.; Marshall, N.; Marshall, T.; Amendt, B.; Mathews, M. B.; Price, D. H., Transcription elongation factor P-TEFb is required for HIV-1 tat transactivation in vitro. *Genes & development* **1997**, *11* (20), 2622-32.
96. Echaliier, A.; Endicott, J. A.; Noble, M. E., Recent developments in cyclin-dependent kinase biochemical and structural studies. *Biochimica et biophysica acta* **2010**, *1804* (3), 511-9.
97. Zhou, M.; Halanski, M. A.; Radonovich, M. F.; Kashanchi, F.; Peng, J.; Price, D. H.; Brady, J. N., Tat modifies the activity of CDK9 to phosphorylate serine 5 of the RNA polymerase II carboxyl-terminal domain during human immunodeficiency virus type 1 transcription. *Molecular and cellular biology* **2000**, *20* (14), 5077-86.
98. D'Orso, I.; Jang, G. M.; Pastuszak, A. W.; Faust, T. B.; Quezada, E.; Booth, D. S.; Frankel, A. D., Transition step during assembly of HIV Tat:P-TEFb transcription complexes and transfer to TAR RNA. *Molecular and cellular biology* **2012**, *32* (23), 4780-93.
99. (a) Garber, M. E.; Wei, P.; Jones, K. A., HIV-1 Tat interacts with cyclin T1 to direct the P-TEFb CTD kinase complex to TAR RNA. *Cold Spring Harbor symposia on quantitative biology* **1998**, *63*, 371-80; (b) Garber, M. E.; Wei, P.; KewalRamani, V. N.; Mayall, T. P.; Herrmann, C. H.; Rice, A. P.; Littman, D. R.; Jones, K. A., The interaction between HIV-1 Tat and human cyclin T1 requires zinc and a critical cysteine residue that is not conserved in the murine CycT1 protein. *Genes & development* **1998**, *12* (22), 3512-27.
100. Tahirov, T. H.; Babayeva, N. D.; Varzavand, K.; Cooper, J. J.; Sedore, S. C.; Price, D. H., Crystal structure of HIV-1 Tat complexed with human P-TEFb. *Nature* **2010**, *465* (7299), 747-51.
101. Mousseau, G.; Mediouni, S.; Valente, S. T., Targeting HIV Transcription: The Quest for a Functional Cure. *Current topics in microbiology and immunology* **2015**, *389*, 121-45.
102. Razooky, B. S.; Pai, A.; Aull, K.; Rouzine, I. M.; Weinberger, L. S., A Hardwired HIV Latency Program. *Cell* **2015**, *160* (5), 990-1001.
103. Siliciano, J. D.; Siliciano, R. F., Recent developments in the search for a cure for HIV-1 infection: targeting the latent reservoir for HIV-1. *The Journal of allergy and clinical immunology* **2014**, *134* (1), 12-9.
104. (a) Anand, K.; Schulte, A.; Vogel-Bachmayr, K.; Scheffzek, K.; Geyer, M., Structural insights into the cyclin T1-Tat-TAR RNA transcription activation complex from EIAV. *Nature structural & molecular biology* **2008**, *15* (12), 1287-92; (b) Salerno, D.; Hasham, M. G.; Marshall, R.; Garriga, J.; Tsygankov, A. Y.; Grana, X., Direct inhibition of CDK9 blocks HIV-1 replication without preventing T-cell activation in primary human peripheral blood lymphocytes. *Gene* **2007**, *405* (1-2), 65-78; (c) Chiu, Y. L.; Cao, H.; Jacque, J. M.; Stevenson, M.; Rana, T. M., Inhibition of human immunodeficiency virus type 1 replication by RNA interference directed against human transcription elongation factor P-TEFb (CDK9/CyclinT1). *Journal of virology* **2004**, *78* (5), 2517-29; (d) Meredith, L. W.; Sivakumaran, H.; Major, L.; Suhrbier, A.; Harrich, D., Potent inhibition of HIV-1 replication by a Tat mutant. *PloS one* **2009**, *4* (11), e7769; (e) Jadowsky, J. K.; Nojima, M.; Schulte, A.; Geyer, M.; Okamoto, T.; Fujinaga, K., Dominant negative mutant cyclin T1 proteins inhibit HIV transcription by specifically degrading Tat. *Retrovirology* **2008**, *5*, 63; (f) Fujinaga, K.; Irwin, D.; Taube, R.; Zhang, F.; Geyer, M.; Peterlin, B. M., A minimal chimera of human cyclin T1 and tat binds TAR and activates human immunodeficiency virus transcription in murine cells. *Journal of virology* **2002**, *76* (24), 12934-9.
105. (a) Agbottah, E.; Zhang, N.; Dadgar, S.; Pumfery, A.; Wade, J. D.; Zeng, C.; Kashanchi, F., Inhibition of HIV-1 virus replication using small soluble Tat peptides. *Virology* **2006**, *345* (2), 373-89; (b) Van Duyne, R.; Cardenas, J.;

- Easley, R.; Wu, W.; Kehn-Hall, K.; Klase, Z.; Mendez, S.; Zeng, C.; Chen, H.; Saifuddin, M.; Kashanchi, F., Effect of transcription peptide inhibitors on HIV-1 replication. *Virology* **2008**, *376* (2), 308-22; (c) Barboric, M.; Yik, J. H.; Czudnochowski, N.; Yang, Z.; Chen, R.; Contreras, X.; Geyer, M.; Matija Peterlin, B.; Zhou, Q., Tat competes with HEXIM1 to increase the active pool of P-TEFb for HIV-1 transcription. *Nucleic acids research* **2007**, *35* (6), 2003-12.
106. Nekhai, S.; Shukla, R. R.; Kumar, A., A human primary T-lymphocyte-derived human immunodeficiency virus type 1 Tat-associated kinase phosphorylates the C-terminal domain of RNA polymerase II and induces CAK activity. *Journal of virology* **1997**, *71* (10), 7436-41.
107. Ali, A.; Ghosh, A.; Nathans, R. S.; Sharova, N.; O'Brien, S.; Cao, H.; Stevenson, M.; Rana, T. M., Identification of flavopiridol analogues that selectively inhibit positive transcription elongation factor (P-TEFb) and block HIV-1 replication. *Chembiochem : a European journal of chemical biology* **2009**, *10* (12), 2072-80.
108. Kashanchi, F., Modulators of viral transcription, and methods and compositions therewith. Google Patents: 2012.
109. Sodroski, J.; Goh, W. C.; Rosen, C.; Tartar, A.; Portetelle, D.; Burny, A.; Haseltine, W., Replicative and cytopathic potential of HTLV-III/LAV with sor gene deletions. *Science* **1986**, *231* (4745), 1549-53.
110. Desimmie, B. A.; Delviks-Frankenberry, K. A.; Burdick, R. C.; Qi, D.; Izumi, T.; Pathak, V. K., Multiple APOBEC3 restriction factors for HIV-1 and one Vif to rule them all. *Journal of molecular biology* **2014**, *426* (6), 1220-45.
111. (a) Yu, X.; Yu, Y.; Liu, B.; Luo, K.; Kong, W.; Mao, P.; Yu, X. F., Induction of APOBEC3G ubiquitination and degradation by an HIV-1 Vif-Cul5-SCF complex. *Science* **2003**, *302* (5647), 1056-60; (b) Jager, S.; Kim, D. Y.; Hultquist, J. F.; Shindo, K.; LaRue, R. S.; Kwon, E.; Li, M.; Anderson, B. D.; Yen, L.; Stanley, D.; Mahon, C.; Kane, J.; Franks-Skiba, K.; Cimermanic, P.; Burlingame, A.; Sali, A.; Craik, C. S.; Harris, R. S.; Gross, J. D.; Krogan, N. J., Vif hijacks CBF-beta to degrade APOBEC3G and promote HIV-1 infection. *Nature* **2012**, *481* (7381), 371-5.
112. (a) Kao, S.; Akari, H.; Khan, M. A.; Dettenhofer, M.; Yu, X. F.; Strebel, K., Human immunodeficiency virus type 1 Vif is efficiently packaged into virions during productive but not chronic infection. *Journal of virology* **2003**, *77* (2), 1131-40; (b) Opi, S.; Kao, S.; Goila-Gaur, R.; Khan, M. A.; Miyagi, E.; Takeuchi, H.; Strebel, K., Human immunodeficiency virus type 1 Vif inhibits packaging and antiviral activity of a degradation-resistant APOBEC3G variant. *Journal of virology* **2007**, *81* (15), 8236-46; (c) Stopak, K.; de Noronha, C.; Yonemoto, W.; Greene, W. C., HIV-1 Vif blocks the antiviral activity of APOBEC3G by impairing both its translation and intracellular stability. *Molecular cell* **2003**, *12* (3), 591-601.
113. Henriet, S.; Sinck, L.; Bec, G.; Gorelick, R. J.; Marquet, R.; Paillart, J. C., Vif is a RNA chaperone that could temporally regulate RNA dimerization and the early steps of HIV-1 reverse transcription. *Nucleic acids research* **2007**, *35* (15), 5141-53.
114. Walker, R. C., Jr.; Khan, M. A.; Kao, S.; Goila-Gaur, R.; Miyagi, E.; Strebel, K., Identification of dominant negative human immunodeficiency virus type 1 Vif mutants that interfere with the functional inactivation of APOBEC3G by virus-encoded Vif. *Journal of virology* **2010**, *84* (10), 5201-11.
115. Feng, Y.; Baig, T. T.; Love, R. P.; Chelico, L., Suppression of APOBEC3-mediated restriction of HIV-1 by Vif. *Frontiers in microbiology* **2014**, *5*, 450.
116. Cruz, N. V.; Amorim, R.; Oliveira, F. E.; Speranza, F. A.; Costa, L. J., Mutations in the nef and vif genes associated with progression to AIDS in elite controller and slow-progressor patients. *Journal of medical virology* **2013**, *85* (4), 563-74.
117. Yu, Y.; Xiao, Z.; Ehrlich, E. S.; Yu, X.; Yu, X. F., Selective assembly of HIV-1 Vif-Cul5-ElonginB-ElonginC E3 ubiquitin ligase complex through a novel SOCS box and upstream cysteines. *Genes & development* **2004**, *18* (23), 2867-72.
118. Salter, J. D.; Morales, G. A.; Smith, H. C., Structural insights for HIV-1 therapeutic strategies targeting Vif. *Trends in biochemical sciences* **2014**, *39* (9), 373-80.
119. (a) Yang, B.; Gao, L.; Li, L.; Lu, Z.; Fan, X.; Patel, C. A.; Pomerantz, R. J.; DuBois, G. C.; Zhang, H., Potent suppression of viral infectivity by the peptides that inhibit multimerization of human immunodeficiency virus type 1 (HIV-1) Vif proteins. *The Journal of biological chemistry* **2003**, *278* (8), 6596-602; (b) Mehle, A.; Wilson, H.; Zhang, C.; Brazier, A. J.; McPike, M.; Pery, E.; Gabuzda, D., Identification of an APOBEC3G binding site in human immunodeficiency virus type 1 Vif and inhibitors of Vif-APOBEC3G binding. *Journal of virology* **2007**, *81* (23), 13235-41.
120. Mulder, L. C.; Harari, A.; Simon, V., Cytidine deamination induced HIV-1 drug resistance. *Proceedings of the National Academy of Sciences of the United States of America* **2008**, *105* (14), 5501-6.
121. Jarmuz, A.; Chester, A.; Bayliss, J.; Gisbourne, J.; Dunham, I.; Scott, J.; Navaratnam, N., An anthropoid-specific locus of orphan C to U RNA-editing enzymes on chromosome 22. *Genomics* **2002**, *79* (3), 285-96.
122. Mohammed, I.; Parai, M. K.; Jiang, X.; Sharova, N.; Singh, G.; Stevenson, M.; Rana, T. M., SAR and Lead Optimization of an HIV-1 Vif-APOBEC3G Axis Inhibitor. *ACS medicinal chemistry letters* **2012**, *3* (6), 465-469.

123. Ali, A.; Wang, J.; Nathans, R. S.; Cao, H.; Sharova, N.; Stevenson, M.; Rana, T. M., Synthesis and structure-activity relationship studies of HIV-1 virion infectivity factor (Vif) inhibitors that block viral replication. *ChemMedChem* **2012**, *7* (7), 1217-29.
124. Zhang, Z.; Zhai, C.; Mi, Z.; Ding, J.; Zhang, Y.; Shi, X.; Li, X.; Yu, L.; Li, Z.; Jiang, J.; Zhou, J.; Cen, S., Molecular modeling of human APOBEC3G to predict the binding modes of the inhibitor compounds IMB26 and IMB35 *Acta Pharmaceutica Sinica B* **2013**, *3* (4), 239-244.
125. Lavens, D.; Peelman, F.; Van der Heyden, J.; Uyttendaele, I.; Catteeuw, D.; Verhee, A.; Van Schoubroeck, B.; Kurth, J.; Hallenberger, S.; Clayton, R.; Tavernier, J., Definition of the interacting interfaces of Apobec3G and HIV-1 Vif using MAPPIT mutagenesis analysis. *Nucleic acids research* **2010**, *38* (6), 1902-12.
126. Sinha, C.; Nischal, A.; Pant, K. K.; Bandaru, S.; Nayarisseri, A.; Khattri, S., Molecular docking analysis of RN18 and VEC5 in A3G-Vif inhibition. *Bioinformation* **2014**, *10* (10), 611-6.